

V1.1 2026-05-15

# Residential Smart Off-Grid Inverter

## EO G2 3.0-6.0kW

- LX A5.0-10
- LX A5.0-30
- GW16.1-BAT-LV-G10

## Solutions Manual

**GOODWE**

# Copyright Statement

## Copyright Statement

**Copyright©GoodWe Technologies Co., Ltd. 2026. All rights reserved.**

Without the authorization of GoodWe Technologies Co., Ltd., no part of this manual may be reproduced, disseminated, or uploaded to public networks or other third-party platforms in any form.

## **Trademark Authorization**

**GOODWE** and other GOODWE trademarks used in this manual are the property of GoodWe Technologies Co., Ltd. All other trademarks or registered trademarks mentioned in this manual belong to their respective owners.

## **NOTICE**

Due to product version upgrades or other reasons, the content of this document is updated periodically. Unless otherwise agreed, the content of this document cannot replace the safety precautions on the product label. All descriptions in this document are for guidance only.

# About This Manual

## Overview





This document primarily introduces the product information, installation wiring, configuration and commissioning, troubleshooting, and maintenance content for the energy storage system composed of inverters, battery systems, and smart meters. Please read this manual carefully before installing and using the product to understand the product safety information and familiarize yourself with the product's functions and features. The document may be updated periodically; please obtain the latest version of the materials and more product information from the official website.

## Applicable Model

The energy storage system includes the following products:

Product Type	Product Information	Description
Inverter	GW3K-EO-G20	Nominal output power: 3.0kW
	GW3.6K-EO-G20	Nominal output power: 3.6kW
	GW5K-EO-G20	Nominal output power: 5.0kW
	GW6K-EO-G20	Nominal output power: 6.0kW
Battery system	LX A5.0-10	Rated capacity 5.0kWh, supports up to 15 clusters in parallel
	LX A5.0-30	Rated capacity 5.12kWh, supports up to 30 clusters in parallel
	GW16.1-BAT-LV-G10	Rated capacity 16.1kWh, supports up to 30 clusters in parallel
Smart Meter	GMK110	Monitoring module in the energy storage system, capable of detecting operating voltage, current, and other information within the system

## Symbol Definition

 <b>DANGER</b>
Indicates a situation with high potential danger, which if not avoided, will result in death or serious injury.
 <b>WARNING</b>
Indicates a situation with moderate potential danger, which if not avoided, could result in death or serious injury.
 <b>CAUTION</b>
Indicates a situation with low potential danger, which if not avoided, could result in moderate or minor injury.
 <b>NOTICE</b>
Emphasizes and supplements the content, may also provide tips or tricks for optimal product use, helping you solve a problem or save your time.

## Table of Contents

1 Safety Precautions	10
1.1 General Safety	10
1.2 personnel requirements	11
1.3 System Safety	12
1.3.1 PV String Safety	14
1.3.2 Inverter Safety	15
1.3.3 Battery Safety	16
1.3.4 Smart Meter Safety	18
1.4 Safety Symbols and Certification Marks	19
2 System Introduction	22
2.1 System Overview	22
2.2 Product Overview	27
2.2.1 Inverter	27
2.2.2 Battery	30
2.2.2.1 LX A5.0-10	30
2.2.2.2 LX A5.0-30	31
2.2.2.3 GW16.1-BAT-LV-G10	32
2.2.3 Smart Meter	33
2.3 Supported Grid Types	34
2.4 System Working Mode	34
2.5 Features	39

3 Check and Storage	41
3.1 Check Before Receiving	41
3.2 deliverables	41
3.2.1 Inverter Deliverables	41
3.2.2 Batteries Deliverables	42
3.2.2.1 Battery Deliverables (LX A5.0-30)	42
3.2.2.2 Battery Deliverables (LX A5.0-10)	44
3.2.2.3 Battery Deliverables (GW16.1-BAT-LV-G10)	45
3.2.3 Combiner Box Deliverables	46
3.2.3.1 BCB-11-WW-0	46
3.2.3.2 BCB-22-WW-0	47
3.2.3.3 BCB-32-WW-0	47
3.2.4 Smart Meter Deliverables	47
3.2.4.1 Smart Meter (GMK110)	48
3.3 Storage	48
4 Installation	51
4.1 System Installation and Commissioning Procedure	51
4.2 Installation Requirements	52
4.2.1 Installation Environment Requirements	52
4.2.2 Installation Space Requirements	54
4.2.3 Tool Requirements	56
4.3 Equipment Handling	58

4.4 Installing the Inverter.....	58
4.5 Installing the Battery System.....	59
4.5.1 LX A5.0-30.....	60
4.5.2 LX A5.0-10.....	63
4.5.3 GW16.1-BAT-LV-G10.....	65
4.6 Installing the Smart Meter.....	66
5 System Wirings.....	68
5.1 System Wiring Electrical Block Diagram.....	68
5.2 Detailed System Wiring Diagram.....	70
5.2.1 Detailed System Wiring Diagram for Single Inverter.....	70
5.3 Preparing Materials.....	73
5.3.1 Preparing Breakers.....	74
5.3.2 Preparing Cables.....	75
5.4 Remove the Lower cover of the Inverter Enclosure.....	77
5.5 Connecting the PE cable.....	78
5.6 Connecting the PV Cable.....	80
5.7 Connecting the Battery Cable.....	81
5.7.1 Connecting the Power Cable between the Inverter and Battery.....	96
5.7.2 Connecting the Communication Cable between the Inverter and Battery.....	99
5.8 Connecting the AC Cable.....	101
5.9 Connecting the Meter Cable.....	102

5.10 Connecting the Inverter Communication Cable	103
5.11 Installing the Inverter Case Lower Cover	107
5.12 Installing the Battery Protection Cover	107
5.12.1 LX A5.0-10	108
5.12.2 LX A5.0-30	108
5.12.3 GW16.1-BAT-LV-G10	108
6 System Commissioning	109
6.1 Check Before Power ON	109
6.2 Power ON	109
6.3 Indicators	111
6.3.1 Battery Indicators	111
6.3.1.1 LX A5.0-10	111
6.3.1.2 LX A5.0-30	113
6.3.1.3 GW16.1-BAT-LV-G10	114
6.3.2 Smart Meter Indicator	117
7 System Commissioning	118
7.1 Commissioning Method Overview	118
7.2 Configuration via LCD	118
7.2.1 LCD Overview	118
7.2.2 Quick Settings	120
7.2.3 Setting Advanced Parameters	127
7.2.4 Setting Immediate Charging	128

7.2.5 Setting the Basic Information	129
7.2.6 Setting Port Connection	130
7.2.7 Setting Communication	134
7.2.8 Viewing Device Information	135
8 System Commissioning and Power Plant Monitoring	137
8.1 Setting Inverter Parameters via App	137
8.1.1 Downloading and Installing SEMS+ App	137
8.2 Power Plant Monitoring via SEMS+ WEB	138
9 Maintenance	139
9.1 Power OFF the System	139
9.2 Removing the Equipment	141
9.3 Disposing of the Equipment	142
9.4 Routine Maintenance	142
9.5 fault	144
9.5.1 Viewing Fault/Alarms Information	144
9.5.2 Fault Information and Troubleshooting	144
9.5.2.1 System Fault	145
9.5.2.2 Inverter Fault	146
9.5.2.2.1 Troubleshooting (Fault Code F01-F40)	146
9.5.2.2.2 Troubleshooting (Fault Code F41-F80)	164
9.5.2.2.3 Troubleshooting (Fault Code F81-F121)	173
9.5.2.2.4 Troubleshooting (Fault Code F122-F163)	185

9.5.2.2.5 Fault Phenomenon Handling	194
9.5.2.3 Battery Fault (LX A5.0-10)	212
9.5.2.4 Battery Fault (LX A5.0-30)	214
9.5.2.5 Battery Fault (GW16.1-BAT-LV-G10)	218
10 technical parameter	222
10.1 Battery Technical Data	222
10.1.1 LX A5.0-10	222
10.1.2 LX A5.0-30	223
10.1.3 GW16.1-BAT-LV-G10	225
10.2 Smart Meter Technical Data	227
10.2.1 GMK110	227
11 Appendix	229
11.1 FAQ	229
11.1.1 How to conduct auxiliary detection for smart meters/CT?	229
11.1.2 How to Upgrade the Device Version	229
11.2 Explanation of Terms	230
11.3 Battery SN Code Meaning	231
12 Contact Details	233

# 1 Safety Precautions

The Safety Precautions information contained in this document must always be observed when operating the equipment.

## WARNING

The device has been strictly designed and tested in accordance with safety regulations. However, as electrical equipment, relevant safety instructions must be followed before performing any operations. Improper operation may result in serious injury or property damage.

## 1.1 General Safety

### NOTICE

- Due to product version upgrades or other reasons, the document content will be updated periodically. Unless otherwise agreed, the document content cannot replace the safety precautions on the product label. All descriptions in the document are for guidance only.
- Please read this document carefully before installing the equipment to understand the product and precautions.
- All operations on the equipment must be performed by professional and qualified electrical technicians who are familiar with the relevant standards and safety regulations at the project location.
- When operating the equipment, use insulated tools and wear personal protective equipment to ensure personal safety. Wear anti-static gloves, anti-static wrist straps, anti-static clothing, etc., when touching electronic components to protect the equipment from electrostatic damage.
- Unauthorized disassembly or modification may cause equipment damage, and such damage is not covered by the warranty.
- Equipment damage or personal injury caused by failure to install, use, or configure the equipment in accordance with the requirements of this document or the corresponding user manual is beyond the manufacturer's liability. For more product warranty information, please obtain it through the official website: <https://en.goodwe.com/warrantyrelated.html>.

## 1.2 personnel requirements

## NOTICE

To ensure safety, compliance, and efficiency throughout the entire process of equipment transportation, Installation, wiring, operation, and maintenance, all tasks must be performed by professionals or qualified personnel.

1. Professionals or qualified personnel include:
  - Individuals who have mastered knowledge of equipment working principles, system architecture, associated risks and hazards, and have received professional operation training or possess extensive practical experience.
  - Individuals who have received relevant technical and safety training, possess certain operational experience, are aware of the potential dangers specific tasks may pose to themselves, and can take protective measures to minimize risks to themselves and others.
  - Qualified electrical technicians who meet the regulatory requirements of the country/region where they are located.
  - Individuals holding an electrical engineering degree/advanced diploma in electrical subjects or equivalent/professional qualifications in the electrical field, and possessing at least 2/3/4 years of experience in testing and regulatory work using electrical equipment safety standards.
2. Personnel involved in special tasks such as electrical work, work at heights, and special equipment operation must hold valid qualification certificates required by the location of the equipment.
3. Operation of medium-voltage equipment must be performed by certified high-voltage electricians.
4. Replacement of equipment and components is only permitted to be carried out by authorized personnel.

## 1.3 System Safety



- Before making electrical connections, disconnect all upstream switches of the equipment to ensure it is powered off. Live operation is strictly prohibited, otherwise hazards such as electric shock may occur.
- To prevent personal injury or equipment damage caused by live operation, a circuit breaker must be added to the voltage input side of the equipment.
- During all operations such as transportation, storage, installation, operation, use, and maintenance, comply with applicable laws, regulations, standards, and specification requirements.
- The specifications of cables and components used for electrical connections must comply with local laws, regulations, standards, and specification requirements.
- Please use the cable connectors provided in the box to connect the equipment cables. If other models of connectors are used, any resulting equipment damage is not within the responsibility of the equipment manufacturer.
- Ensure all cable connections on the equipment are correct, secure, and not loose. Improper wiring may cause poor contact or damage the equipment.
- The equipment's protective ground wire must be securely connected.
- To protect the equipment and its components from damage during transportation, ensure the transport personnel are professionally trained. Record the operation steps during transportation and keep the equipment balanced to avoid dropping.
- The equipment is heavy. Please allocate personnel corresponding to the equipment's weight to prevent it from exceeding the human body's carrying capacity, which could cause injury from falling equipment.
- Ensure the equipment is placed stably and not tilted. Equipment tipping over may cause equipment damage and personal injury.



- During equipment Installation, avoid placing weight on the terminals, as this will cause terminal damage.
- If the cable bears excessive tension, it may lead to poor connection. When wiring, leave a certain length of cable slack before connecting it to the equipment's wiring port.
- Cables of the same type should be bundled together. Different types of cables should be routed at least 30mm apart and must not be intertwined or crossed.
- Using cables in high-temperature environments may cause insulation aging and damage. Maintain a distance of at least 30mm between cables and heat-generating components or the periphery of heat source areas.

### **1.3.1 PV String Safety**

## WARNING

- Ensure the component frame and mounting system are properly grounded.
- After connecting the DC cables, ensure they are securely fastened and not loose. Improper wiring may cause poor contact or high impedance, and damage the inverter.
- Use a multimeter to measure the positive and negative poles of the DC cables to ensure correct polarity, with no reverse connection; and that the voltage is within the allowable range.
- Use a multimeter to measure the DC cables to ensure correct polarity, with no reverse connection; the voltage should be lower than the maximum DC input voltage. Damage caused by reverse connection and overvoltage is not covered by the equipment manufacturer's warranty.
- The PV string output does not support grounding. Before connecting the PV string to the inverter, ensure the minimum insulation resistance to ground of the PV string meets the minimum insulation resistance requirement ( $R = \text{Max. Input Voltage (V)} / 30\text{mA}$ ).
- Do not connect the same PV string to multiple inverters, as this may cause inverter damage.
- Photovoltaic modules used with the inverter must comply with IEC 61730 Class A standard.
- When the PV string input voltage or input current is high, it may cause the inverter output power to derate.

### 1.3.2 Inverter Safety

## WARNING

- Ensure that the voltage and frequency at the grid connection point comply with the inverter's grid connection specifications.
- It is recommended to add protective devices such as circuit breakers or fuses on the AC side of the inverter. The specification of the protective device should be greater than 1.25 times the maximum AC output current of the inverter.
- If the inverter triggers an arc fault alarm less than 5 times within 24 hours, the alarm can be automatically cleared. After the 5th arc fault alarm, the inverter will shut down for protection. The inverter can only resume normal operation after the fault is cleared.
- If no battery is configured in the photovoltaic system, it is not recommended to use the BACK-UP function, as it may cause a risk of system power outage.
- Changes in grid voltage and frequency may cause the inverter output power to derate.

### 1.3.3 Battery Safety

## DANGER

- Before operating any device in the system, ensure the device is powered off to avoid the risk of electric shock. During device operation, strictly adhere to all safety precautions in this manual and the safety labels on the device.
- Do not disassemble, modify, or repair the battery or control box without official authorization from the manufacturer, as this may pose an electric shock hazard or cause device damage. Losses resulting from such actions are beyond the manufacturer's liability.
- Do not impact, pull, drag, squeeze, or step on the device. Do not place the battery in a fire, as there is a risk of battery explosion.
- Do not place the battery in a high-temperature environment. Ensure there are no heat sources near the battery and that it is not exposed to direct sunlight. A fire may occur if the ambient temperature exceeds 60°C.
- Do not use the battery or control box if there are obvious defects, cracks, damage, or other issues. Battery damage may cause electrolyte leakage.
- Do not move the battery system while it is in operation. If battery replacement or addition is required, please contact the after-sales service center.
- Battery short circuit may cause personal injury. The instantaneous high current from a short circuit can release a large amount of energy, potentially leading to a fire.
- The battery DC circuit breaker should comply with the requirements of AS/NZS 5139 standard.

## WARNING

- Battery current may be affected by factors such as temperature, Humidity, weather conditions, etc., which may lead to current limiting and affect load capacity.
- If the battery fails to start, please contact the after-sales service center as soon as possible. Otherwise, the battery may be permanently damaged.
- Please regularly inspect and maintain the battery according to its maintenance requirements.

### Emergency Response Measures

- Battery electrolyte leakage

If the battery module leaks electrolyte, avoid contact with the leaked liquid or gas. The electrolyte is corrosive, and contact may cause skin irritation and chemical burns. If accidental contact occurs with the leaked substance, perform the following actions:

- inhalation: Evacuate from the contaminated area and seek medical help immediately.
- Eye contact: Rinse with clean water for at least 15 minutes and seek medical help immediately.
- Skin contact: Thoroughly wash the affected area with soap and water and seek medical help immediately.
- Ingestion: Induce vomiting and seek medical assistance immediately.

- Fire

- When the battery temperature exceeds 150°C, there is a risk of fire, and the battery may release toxic and harmful gases after catching fire.
- To prevent fires, ensure that carbon dioxide, Novec1230, or FM-200 fire extinguishers are available near the equipment.
- When extinguishing fires, do not use ABC dry powder fire extinguishers. Firefighters must wear protective clothing and self-contained breathing apparatus.

- Battery triggers fire protection

For batteries equipped with fire protection functions, after the fire protection function is triggered, perform the following actions:

- Immediately cut off the main power switch to ensure no current passes through the battery system.
- Conduct a preliminary inspection of the battery's appearance for any damage, deformation, leakage, or unusual odors. Check the battery's casing, connectors, and cables.
- Use a temperature sensor to detect the battery and its ambient temperature to ensure there is no risk of overheating.
- Isolate and mark the damaged battery, and dispose of it properly according to local regulations.

### **1.3.4 Smart Meter Safety**





## WARNING









If the grid voltage fluctuation exceeds 265V, long-term overvoltage operation may damage the electric meter. It is recommended to add a fuse with a rated current of 0.5A on the voltage input side of the meter to protect it.



## 1.4 Safety Symbols and Certification Marks

### DANGER

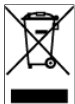
- After equipment installation, the labels and warning signs on the enclosure must be clearly visible. Do not obstruct, alter, or damage them.
- The enclosure warning label descriptions below are for reference only. Please refer to the actual labels used on the equipment.

No.	Symbol	Meaning
1		Potential hazards exist during equipment operation. Take protective measures when operating the equipment.
2		High voltage hazard. High voltage is present during equipment operation. Ensure the equipment is powered off before operation.
3		High temperature on the inverter surface. Do not touch during operation to avoid burns.
4		Use the equipment properly. Operating under extreme conditions may pose an explosion risk.
5		The battery contains flammable materials. Risk of fire.

No.	Symbol	Meaning
6		The equipment contains corrosive electrolyte. Avoid contact with leaked electrolyte or vapor.
7		Delayed discharge. After powering off the equipment, wait 5 minutes for it to fully discharge.
8		Keep the equipment away from open flames or ignition sources.
9		Keep the equipment out of reach of children.
10		Do not extinguish with water.
11		Read the product manual carefully before operating the equipment.
12		Wear personal protective equipment during installation, operation, and maintenance.
13		Do not dispose of the equipment as household waste. Dispose of it according to local laws and regulations, or return it to the manufacturer.
14		Grounding point.
15		Recycling symbol.

No.	Symbol	Meaning
16		CE marking.
17		TUV mark.
18		RCM mark.

## 2 System Introduction

### 2.1 System Overview

The residential Smart Inverter solution integrates devices such as the inverter, Battery, Smart Meter, and smart communication stick. It converts solar energy into electricity within the photovoltaic system to meet household electricity demands. The energy IoT devices in the system manage electrical appliances by identifying the overall power situation in the system, thereby achieving intelligent management of power for use by loads, storage in the Battery.

 **WARNING**

- Battery models should be selected based on the inverter and battery matching list. For requirements of batteries used in the same system, such as whether models can be mixed, whether capacities should be consistent, etc., please refer to the user manual of the corresponding battery model or contact the battery manufacturer for relevant requirements. Inverter and battery compatibility list: [https://en.goodwe.com/Ftp/EN/Downloads/User%20Manual/GW\\_Battery%20Compatibility%20Overview-EN.pdf](https://en.goodwe.com/Ftp/EN/Downloads/User%20Manual/GW_Battery%20Compatibility%20Overview-EN.pdf).
- Due to product version upgrades or other reasons, the document content will be updated periodically. The matching relationship between inverters and IoT products can be referred to: [https://en.goodwe.com/Ftp/EN/Downloads/User%20Manual/GW\\_Compatibility-list-of-GoodWe-inverters-and-IoT-products-EN.pdf](https://en.goodwe.com/Ftp/EN/Downloads/User%20Manual/GW_Compatibility-list-of-GoodWe-inverters-and-IoT-products-EN.pdf).
- For detailed networking and wiring schemes for each scenario, please refer to: [5.2.Detailed System Wiring Diagram\(Page 70\)](#).
- Energy storage systems are not suitable for connecting devices that rely on stable power supply, such as life-sustaining medical equipment, etc. Please ensure that system power failure does not cause personal injury.
- In inverter completely off-grid operation systems, if the battery is in low light or rainy weather for a long time and fails to replenish power in time, it may lead to over-discharge, causing battery performance degradation or damage. To ensure long-term stable operation of the system, avoid the battery being completely drained. Recommended measures are as follows:
  1. During off-grid operation, set the minimum SOC protection threshold. It is recommended to set the off-grid battery SOC lower limit to 30%.
  2. When SOC approaches the protection threshold, the system will automatically enter load limiting or protection mode.
  3. If there is insufficient light for several consecutive days and the battery SOC is too low, promptly replenish the battery energy through external energy sources (such as generators or grid-assisted charging).
  4. Regularly check the battery status to ensure it is within the safe operating range.
  5. It is recommended to fully charge and discharge the battery every six months to calibrate SOC accuracy.

Off-Grid Load Capacity Specifications		
Inverter Model	GW3K-EO-G20 GW3.6K-EO-G20	GW5K-EO-G20 GW6K-EO-G20
Single Inductive Load Rated Power (kVA)	0.8	1.5
Total Inductive Load Rated Power (kVA)	$0.75 * P_n$	$0.75 * P_n$
Capacitive Load (kVA)	$0.33 * P_n$	$0.33 * P_n$
Half-wave Load	$0.5 * P_n$	$0.5 * P_n$
Note: $P_n$ : Inverter rated output power.		

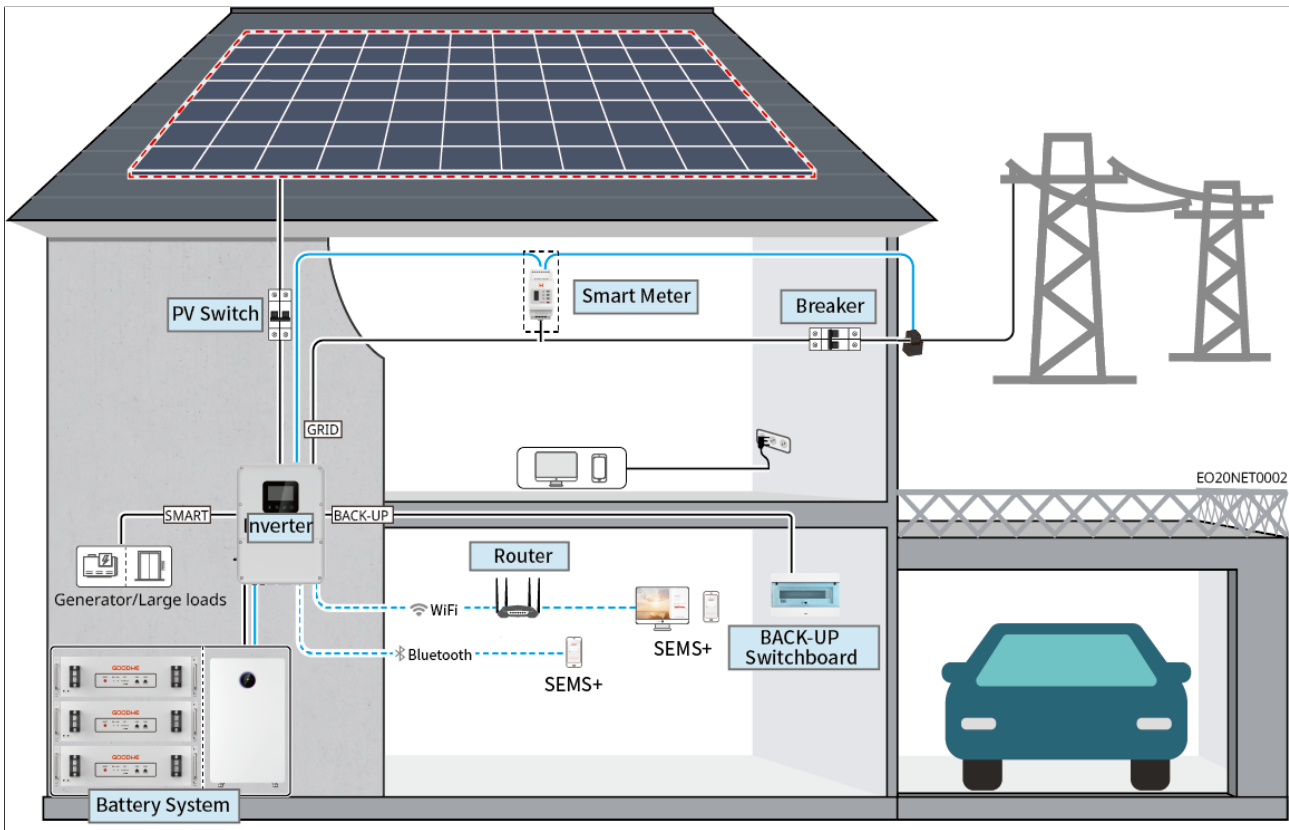

Figure1 System Network Diagram

Device Type	model	Description
Inverter	GW3K-EO-G20 GW3.6K-EO-G20 GW5K-EO-G20 GW6K-EO-G20	<ul style="list-style-type: none"> <li>• Supports connection to generator or large load</li> <li>• If the Inverter needs to be compatible with GW16.1-BAT-LV-G10, the software version requirements are as follows:               <ul style="list-style-type: none"> <li>◦ DSP: Version 1.25 and above</li> <li>◦ ARM: Version 1.121 and above</li> </ul> </li> </ul>
Battery system	LX A5.0-10	<ul style="list-style-type: none"> <li>• Battery systems of different models cannot be mixed and used together.</li> <li>• Expansion by clustering is temporarily not supported between different models. For the same model, expansion by clustering is allowed within one year of purchase and use, and not allowed after one year.</li> <li>• After battery clustering and expansion, the charge and discharge SOC of the batteries may become unbalanced in the short term, which does not affect product safety and basic functions. The system will automatically perform balance correction.</li> <li>• LX A5.0-10: Supports a maximum of 15 units clustered in the same system</li> <li>• LX A5.0-30: Supports a maximum of 30 units clustered in the same system</li> <li>• GW16.1-BAT-LV-G10: Supports a maximum of 30 units clustered in the same system</li> </ul>
	LX A5.0-30	
	GW16.1-BAT-LV-G10	
	Lead-acid battery	<ul style="list-style-type: none"> <li>• Supports connection to AGM, GEL, and Flooded types of lead-acid batteries</li> <li>• Calculate the number of batteries that can be connected in series based on the lead-acid battery voltage. The total voltage of series-connected batteries must not exceed 60V.</li> </ul>

Device Type	model	Description
Combiner box	BCB-11-WW-0 BCB-22-WW-0 BCB-32-WW-0 (purchased from GoodWe)	<ul style="list-style-type: none"> <li>• When multiple batteries are used in the system, a combiner box can be optionally connected. If using batteries from other brands, please consult the corresponding manufacturer for the connection method between the battery and the busbar.</li> <li>• When a busbar or combiner box is used in the system to connect the battery and the inverter. (current <math>\geq</math> IBat rated. (IBat rated: battery maximum charge/discharge current).</li> <li>• BCB-11-WW-0: Used with LX A5.0-10, the battery system supports a maximum working current of 360A and a maximum connection of 6 batteries</li> <li>• BCB-22-WW-0: <ul style="list-style-type: none"> <li>◦ Used with LX A5.0-10, the battery system supports a maximum working current of 720A and a maximum connection of 12 batteries</li> <li>◦ Used with LX A5.0-30, the battery system supports a maximum working current of 720A and a maximum connection of 6 batteries</li> </ul> </li> <li>• BCB-32-WW-0: <ul style="list-style-type: none"> <li>◦ Used with LX A5.0-10, the battery system supports a maximum working current of 720A and a maximum connection of 15 batteries</li> <li>◦ Used with LX A5.0-30, the battery system supports a maximum working current of 720A and a maximum connection of 15 batteries</li> <li>◦ Used with GW16.1-BAT-LV-G10, the battery system supports a maximum working current of 720A and a maximum connection of 15 batteries</li> </ul> </li> <li>• Others: Please configure according to the system power and current</li> </ul>
Smart Meter	Built-in meter (standard-equipped)	CT can be purchased from dealers or on your own. CT ratio requirement: 120A:40mA

Device Type	model	Description
	GMK110 (purchased from dealer)	<ul style="list-style-type: none"> <li>When the length of the built-in CT cable of the inverter is insufficient to connect to the distribution board, it can be extended by externally connecting the GMK110 meter.</li> <li>GMK110: CT cannot be replaced; CT ratio: 120A/40mA</li> </ul>
Large load		<p>Supports SG Ready. Large load specifications require:</p> <ol style="list-style-type: none"> <li>Total power of large load &lt; Maximum output power of SMART port</li> <li>Large load power + BACK-UP power &lt; Maximum AC input power (Utility grid)</li> </ol>
Generator		Generator rated voltage must meet the rated voltage of the inverter SMART port

## 2.2 Product Overview

### 2.2.1 Inverter

Off-grid inverters in photovoltaic systems control and optimize energy flow through integrated energy management systems. They can supply the electricity generated in the photovoltaic system to loads, store it in batteries, etc.

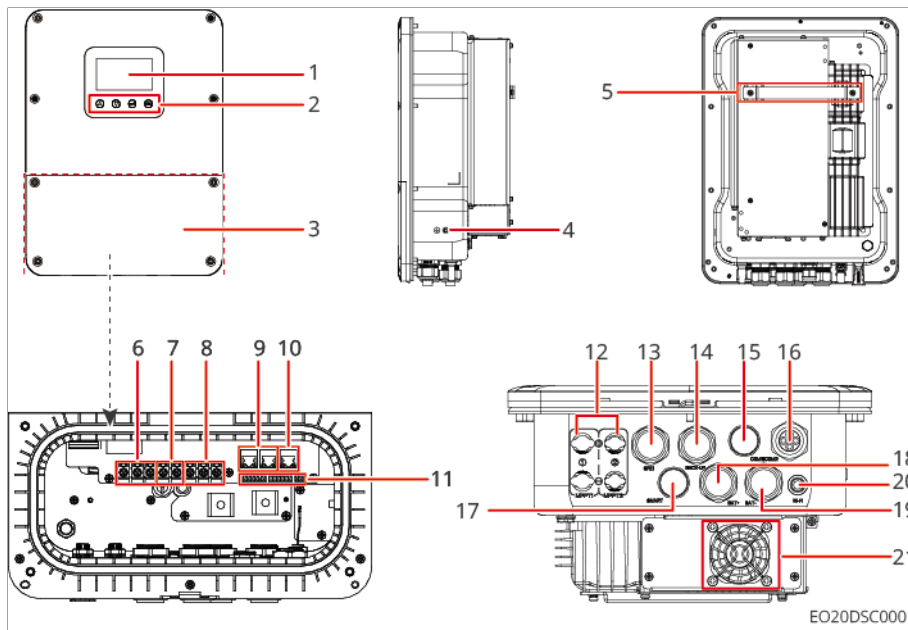

Figure2 Inverter Component Introduction

No.	model	Nominal output power	Nominal output voltage
1	GW3K-EO-G20	3kW	220/230
3	GW3.6K-EO-G20	3.6kW	220/230
4	GW5K-EO-G20	5kW	220/230
5	GW6K-EO-G20	6kW	220/230

No.	Component/Si Ikscreen	Description
1	Display Screen	View inverter-related data
2	Buttons	Used in conjunction with the display to perform setup operations on the inverter
3	Inverter Chassis Lower Cover	-
4	Grounding terminal/PE	Connecting the PE cable
5	Mounting Bracket	Used for mounting the inverter
6	Grid Port/GRID	Connect AC cables to connect the inverter to the grid
7	SMART Port	Used for connecting a generator or large loads

No.	Component/Si lkscreen	Description
8	BACK-UP Port	Connect AC cables to connect critical loads to the inverter
9	(Reserved) Parallel Communicatio n Port	-
10	Battery Communicatio n Port	Connect battery communication cable
11	Communicatio n Port	Can connect communication cables for load control, CT, RS485, Remote Shutdown/Rapid Shutdown, etc.
12	PV Cable Connection Port	Can connect PV module DC input cables. GW3K-EO-G20, GW3.6K-EO-G20: x 1 GW5K-EO-G20, GW6K-EO-G20: x 2
13	GRID	Grid cable outlet
14	BACK-UP	BACK-UP Loads cable outlet
15	COM1	Communication cable outlet
16	COM2	Parallel communication cable and battery communication cable outlet
17	SMART	Generator or large load cable outlet
18	BAT+	Battery positive power cable outlet
19	BAT-	Battery negative power cable outlet
20	antenna	Enhances inverter communication signal
21	Fan	Used for inverter heat dissipation

## Size Introduction

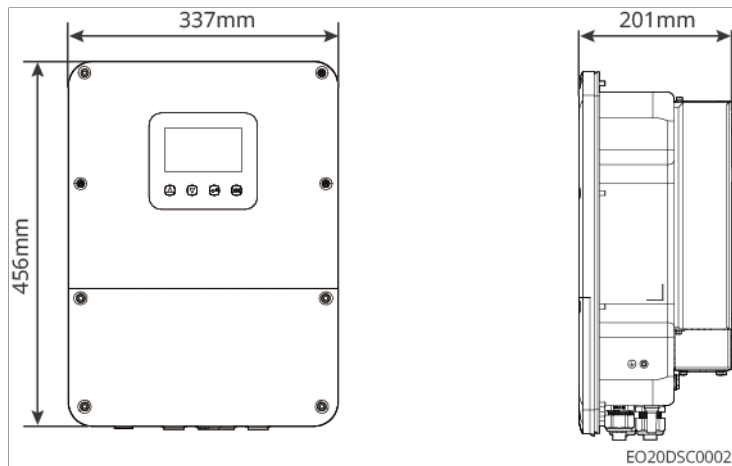
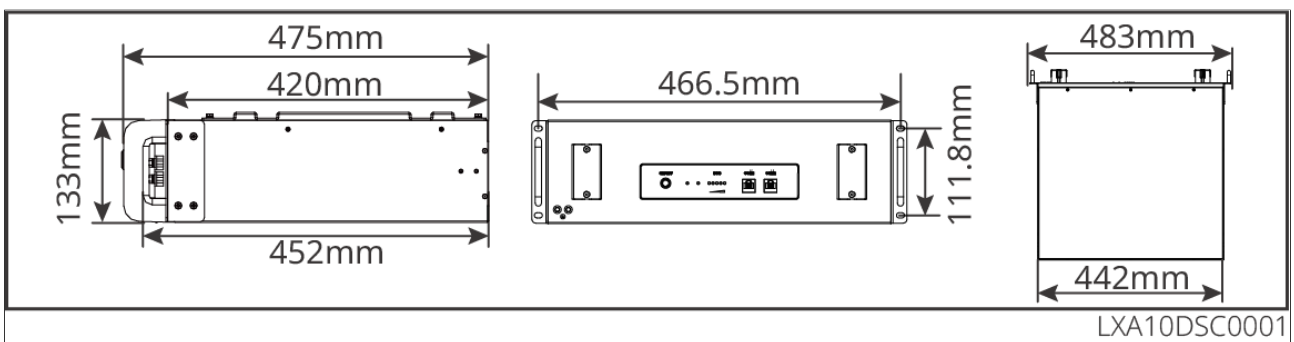

Figure3 Inverter Size

## 2.2.2 Battery

The Battery system can store and release electrical energy according to the requirements of the photovoltaic energy storage system. The input and output ports of this energy storage system are high-voltage direct current. The inverter supports the use with lead-acid Batteries. Please obtain related product information for lead-acid Batteries from the lead-acid Battery manufacturer.

### 2.2.2.1 LX A5.0-10



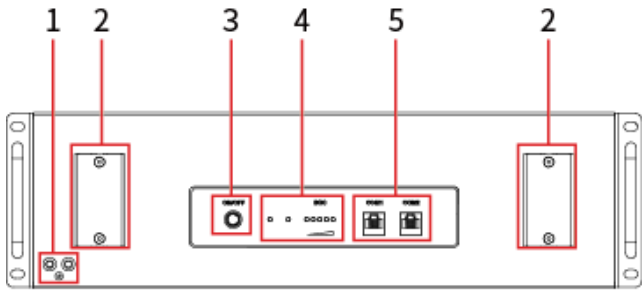

LXA10DSC0002

No.	Component/Silk Screen	Description
1	Grounding terminal	Connect the chassis protective grounding wire.
2	Battery DC Port	Connect the battery DC input cable.
3	Battery System Button	Used for battery power on/off and black start.
4	indicator	Indicates the operating status of the battery.
5	Communication Port	Connect the battery communication cable.

### 2.2.2.2 LX A5.0-30

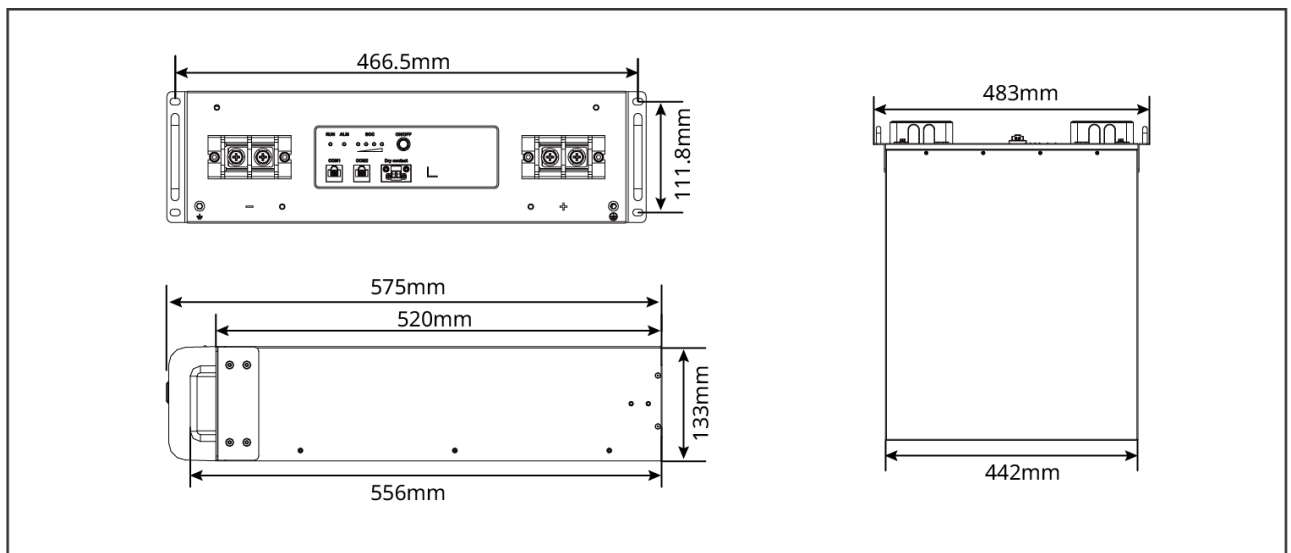

LXA30DSC0001

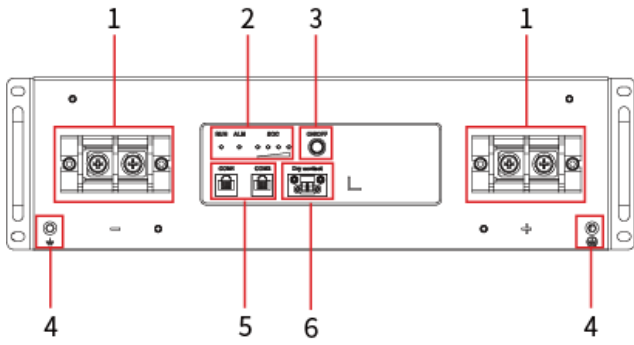

LXA30DSC0002

No.	Component/Silk screen	Description
1	Battery DC port	Connect the battery DC input cable.
2	indicator	Indicates the operating status of the battery.
3	Battery system button	Used for battery power on/off and black start.
4	Grounding terminal	Connect the chassis protective ground wire.
5	Communication Port	Connect the battery communication cable.
6	Dry contact	Reserved.

### 2.2.2.3 GW16.1-BAT-LV-G10

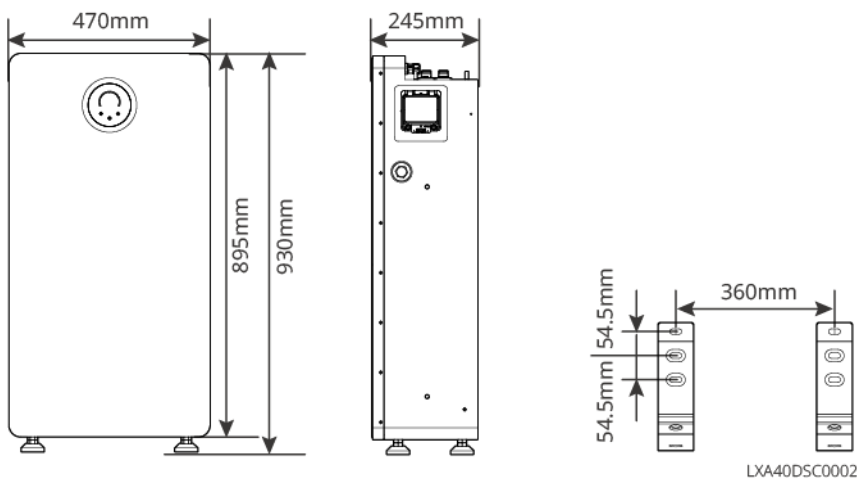

LXA40DSC0002

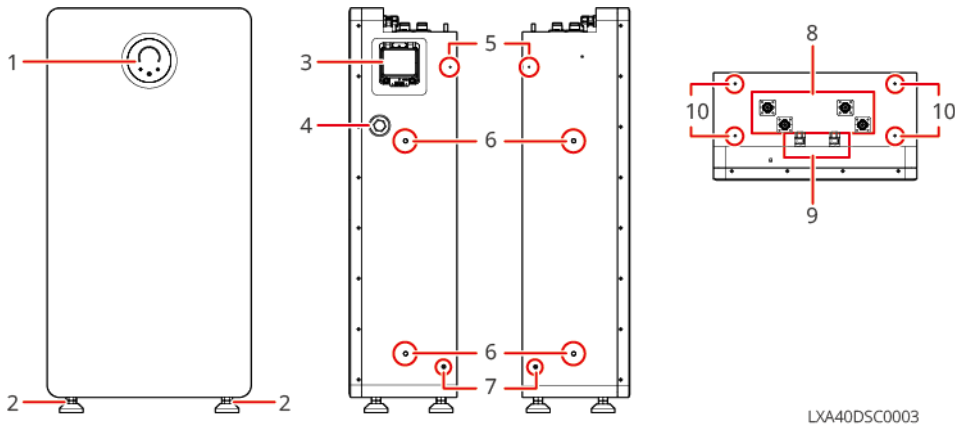

LXA40DSC0003

No.	Component/Silk screen	Description
1	indicator	Indicates the battery's operating status.
2	Foot	Supports the battery.
3	Battery Circuit Breaker	Used for powering the battery on/off.
4	Explosion-proof Vent Valve	Balances internal and external pressure of the battery, explosion-proof.
5	Anti-tip Bracket Mounting Hole	Used to secure the battery to the wall.
6	Lifting Rod Mounting Hole	Used for installing the lifting rod. Used during manual battery transportation.
7	Grounding terminal	Connects to the protective ground wire of the enclosure.
8	Battery DC Port	Connects the battery DC input cable.
9	Communication Port	Connects the battery communication cable.
10	Decorative Cover Mounting Hole	Used to secure the battery decorative cover.

### 2.2.3 Smart Meter

The Smart Meter measures and monitors the electrical data in the photovoltaic energy storage system, such as: voltage, current, Frequency, Power Factor, power, etc.

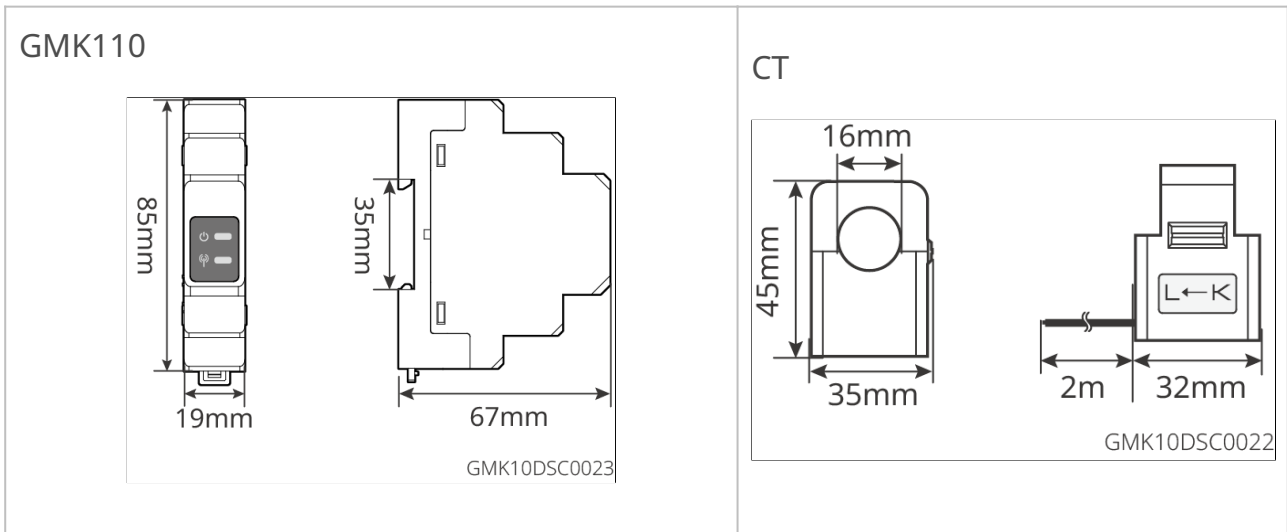

## 2.3 Supported Grid Types

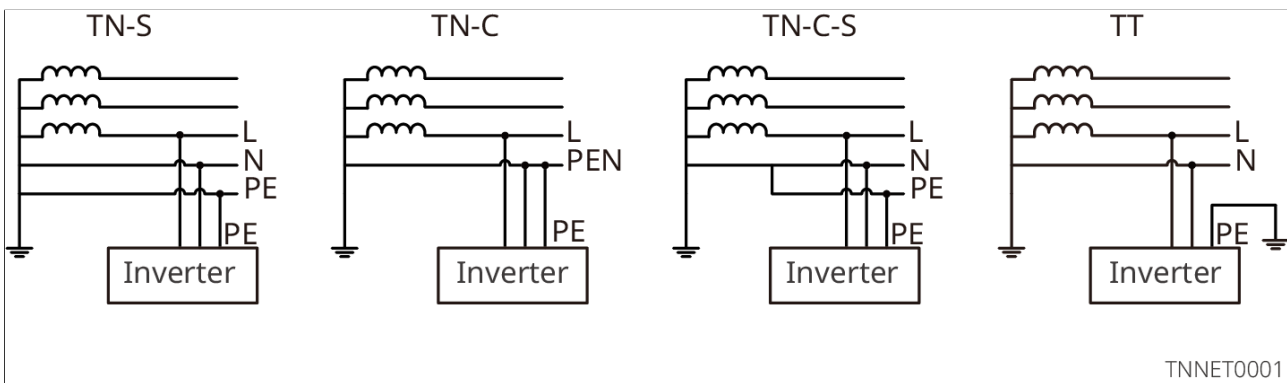

## 2.4 System Working Mode

### Self-consumption

- The basic operating mode of the system.
- PV generation prioritizes supplying power to the loads, and excess power charges the battery. When PV generation does not meet the load demand, the battery supplies power to the loads; when the battery power is also insufficient, the grid supplies power to the loads.

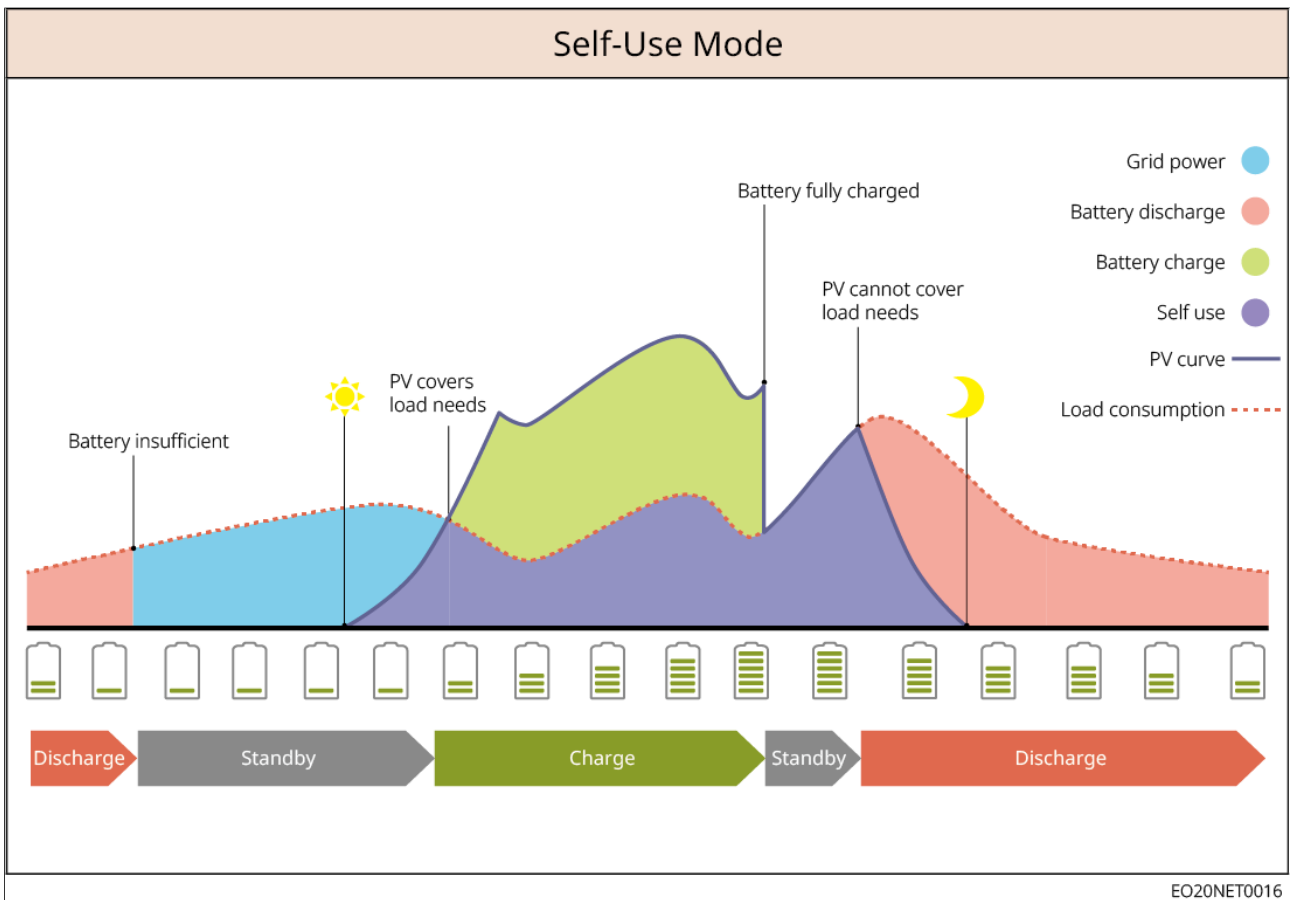

## Backup Mode

- Recommended for use in areas with unstable grid.
- When the grid is out, the inverter switches to off-grid working mode, and the battery discharges to supply power to the loads, ensuring that the BACK-UP Loads do not lose power; when the grid is restored, the inverter switches its working mode to grid-connected operation.
- To ensure that the battery SOC is sufficient to maintain normal system operation when off-grid, during grid-connected operation, the battery will use PV or grid-purchased electricity to charge to the backup power SOC. If it is necessary to purchase electricity from the grid to charge the battery, please ensure compliance with local grid laws and regulations.

# Back-up Mode ①

Charging from grid: disabled

Back-up SOC: 60%

Grid connected      Grid disconnected      Grid connected

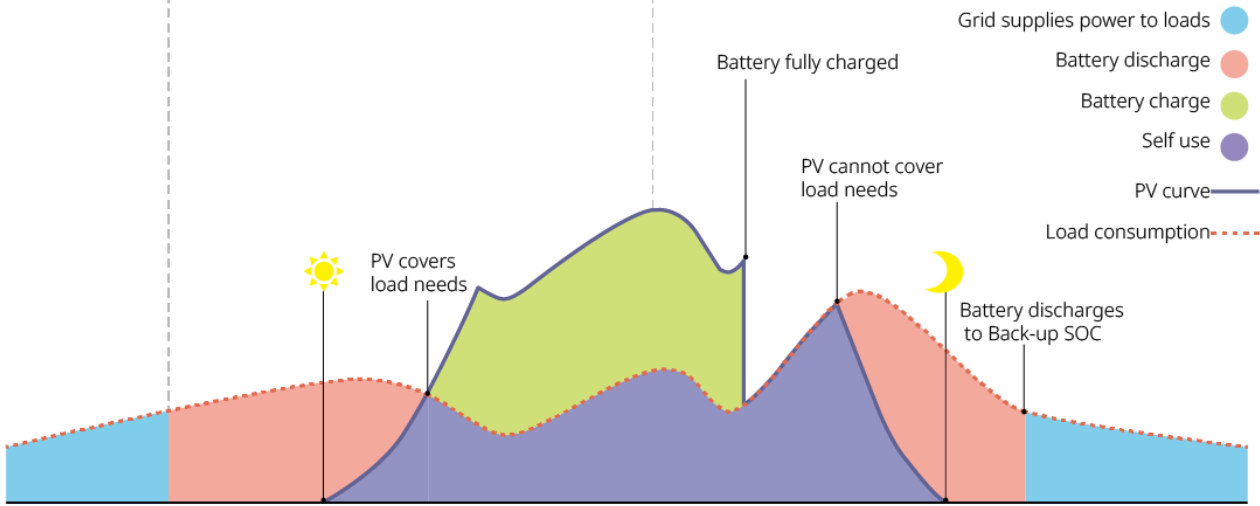

EO20NET0009

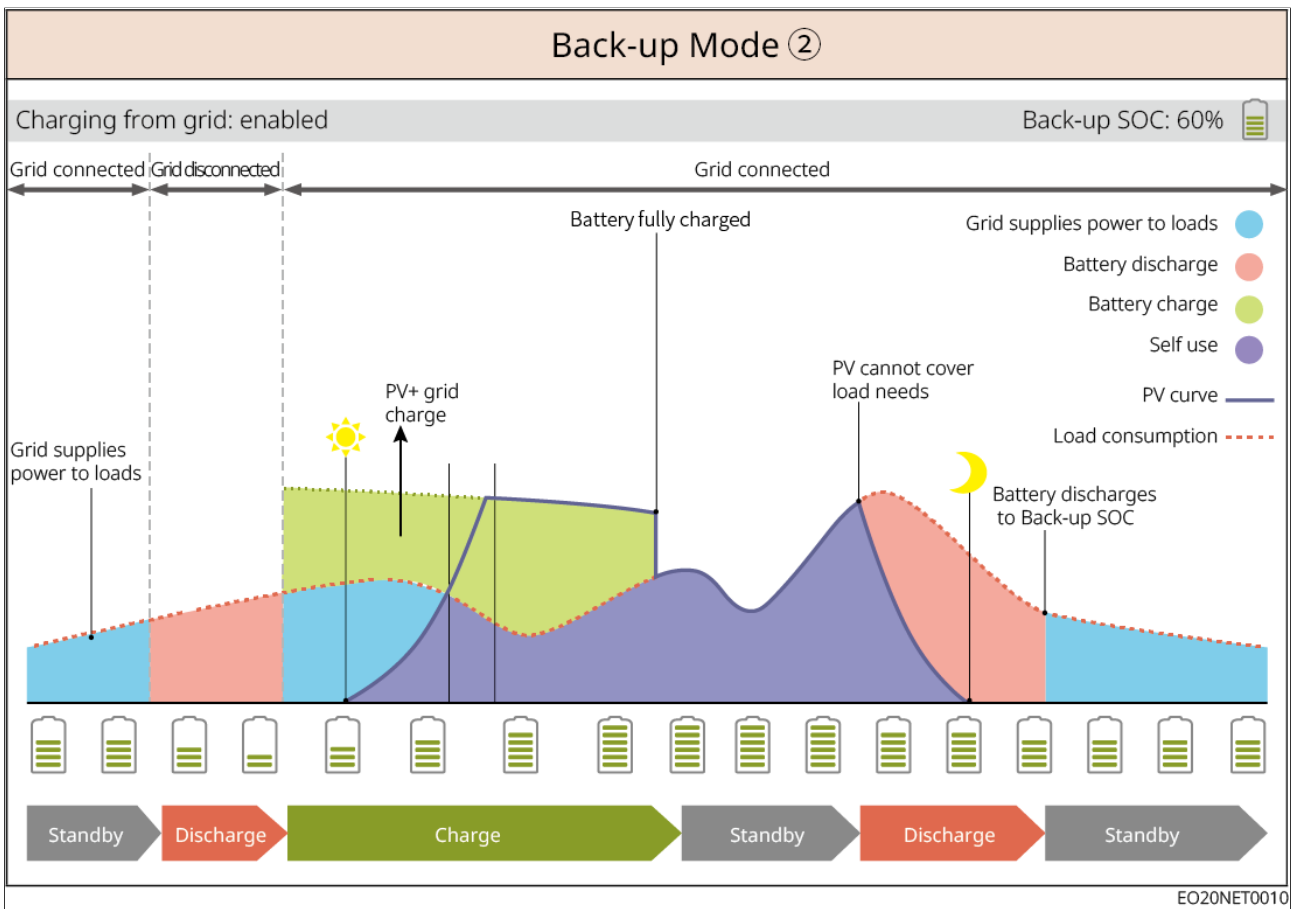

## TOU Mode

Under the premise of complying with local laws and regulations, based on the difference in grid peak and valley electricity prices, set different time periods for purchasing electricity.

For example: during valley electricity price periods, set the battery to charging mode to purchase electricity from the grid for charging; during peak electricity price periods, set the battery to discharging mode to supply power to the loads through the battery.

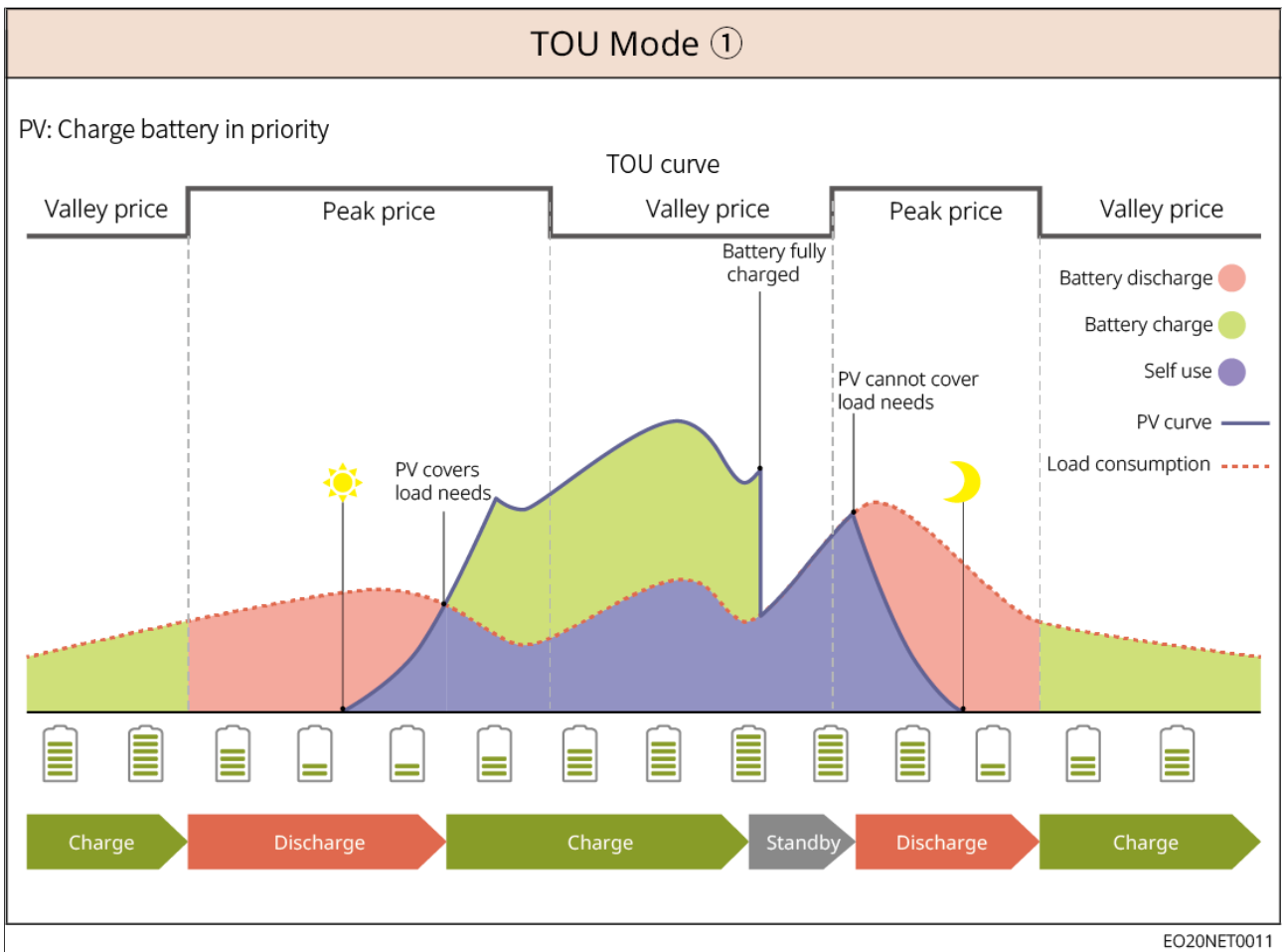

## Off-grid Mode

### NOTICE

Do not operate in pure off-grid mode when the inverter is disconnected from the battery system.

When the grid is out, the inverter switches to off-grid working mode.

- During the day, PV generation prioritizes supplying power to the loads, and excess power charges the battery.
- At night, the battery discharges to supply power to the loads, ensuring that the BACK-UP Loads do not lose power.

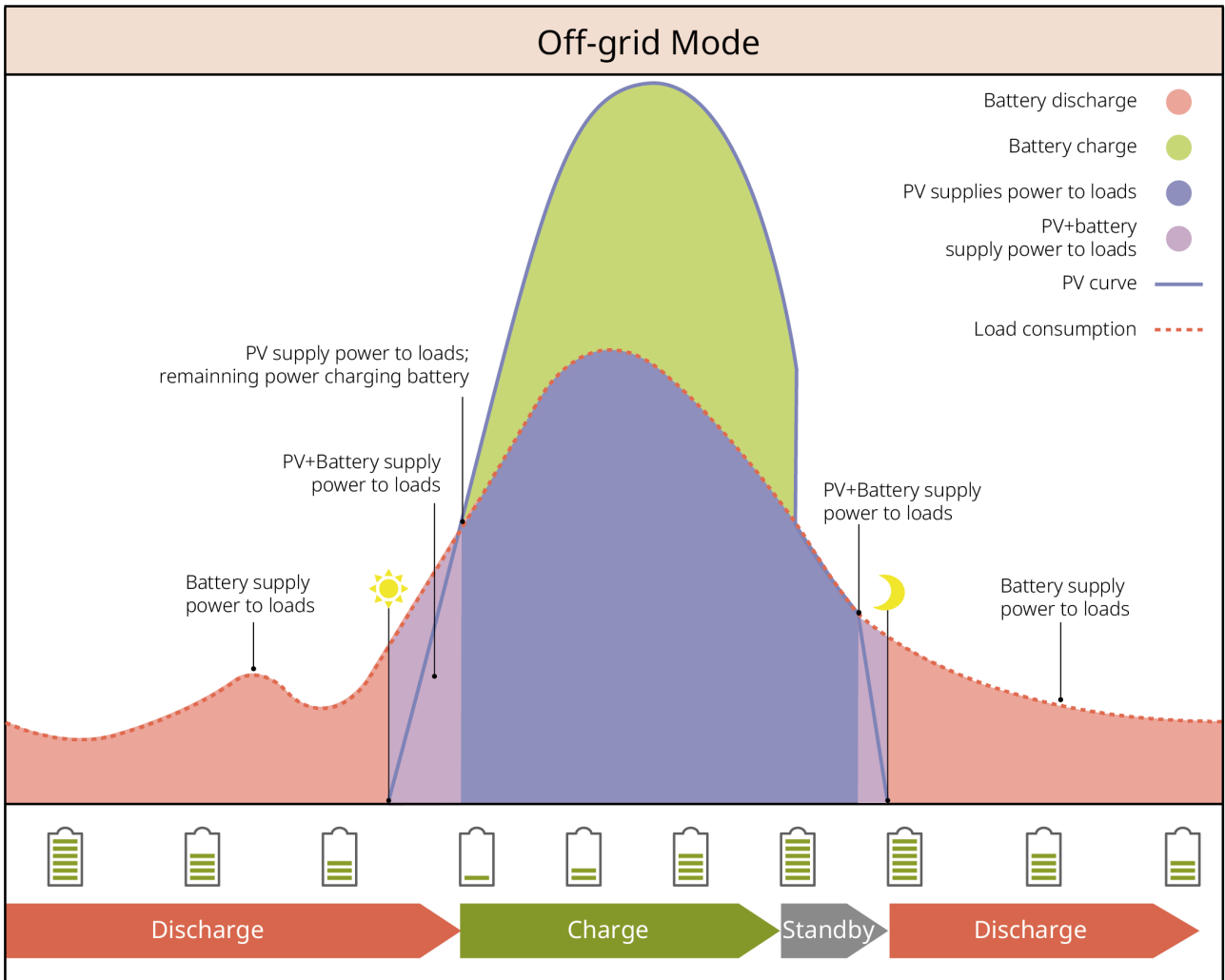

SLG00NET0012

## 2.5 Features

### load control

The inverter's dry contact control port supports connecting an additional contactor for turning the load on or off. Supports household loads, heat pumps, etc.

Load control methods are as follows:

- Dry Contact Mode: When the switch status is set to ON, power supply to the load begins; when the switch status is set to OFF, power supply to the load stops. Please set the switch status to ON or OFF according to actual needs.
- Time Mode: The load will automatically be powered on or off within the set time period. You can choose Standard Mode or Smart Mode.
- SOC Mode: The inverter has a built-in relay dry contact control port, which can control whether to supply power to the load. In off-grid mode, if an overload on

the BACK-UP port or Smart port is detected, or if the battery SOC protection function is triggered, power supply to the load connected to this port can be stopped.

### **Diesel Generator Control**

When the inverter supports the diesel generator control function, you can control the generator's start/stop via the App or LCD screen.

- No Generator Connected: When no generator is connected to the energy storage system, please select 'No Generator Connected'.
- Manually Control Generator (Dry contact connection not supported): The generator must be started/stopped manually; the inverter cannot control the generator.
- Automatically Control Generator (Dry contact connection supported): When the generator has a dry contact control port and is connected to the inverter, you need to set the inverter's generator control mode to Switch Control Mode or Automatic Control Mode.
  - Switch Control Mode: When the switch status is ON, the generator operates; the generator can automatically stop after running for the set duration.
  - Automatic Control Mode: Generator operation is prohibited during the set prohibited operation time period, and it operates during the set operation time period.

# 3 Check and Storage

## 3.1 Check Before Receiving

Before receiving the product, please check the following content in detail:

1. Check if the outer packaging is damaged, such as deformation, holes, cracks, or other signs that might cause damage to the equipment inside the packaging box. If damaged, do not open the packaging and contact your dealer.
2. When taking out the GW16.1-BAT-LV-G10 battery, ensure that the packaging carton is intact. If the packaging is accidentally damaged and you need to handle returns or exchanges due to product quality issues, contact GoodWe after-sales service or your dealer to obtain a dedicated packaging box.
3. Check if the device model is correct. If it does not match, do not open the packaging and contact your dealer.



## 3.2 deliverables







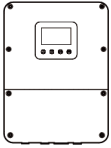
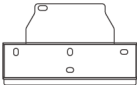
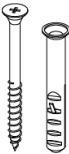

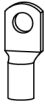
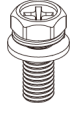
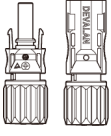

Check if the type and quantity of the delivered items are correct, and if there is any damage to the appearance. If damaged, please contact your dealer.

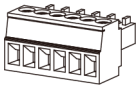
After removing the delivered items from the packaging, do not place them on rough, uneven, or sharp surfaces to avoid paint chipping.



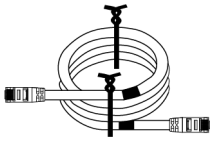



### 3.2.1 Inverter Deliverables



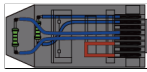
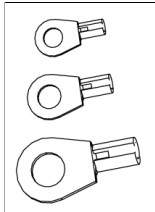

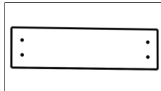
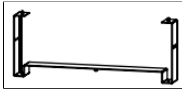

Component	Description	Component	Description
	Inverter x1		mounting plate x1
	Expansion screw x4		Grounding terminal x 1

Component	Description	Component	Description
	Battery power connection terminal x 2		Battery terminal fastening screw
	PV DC wiring terminal <ul style="list-style-type: none"> <li>• GW3K-EO-G20, GW3.6K-EO-G20: x 1</li> <li>• GW5K-EO-G20, GW6K-EO-G20: x 2</li> </ul>		Communication tubular terminal x 16
	2PIN communication terminal x 1		6PIN communication terminal x 2
	AC tubular terminal x 8		Flathead screwdriver x 1
	Communication outlet waterproof plug x 1		BMS communication cable x 1
	PV terminal fastening/unlocking tool x 1		Product documentation x 1

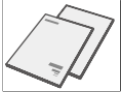



## 3.2.2 Batteries Deliverables



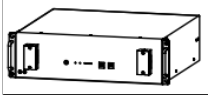
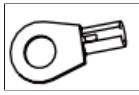

### 3.2.2.1 LX A5.0-30

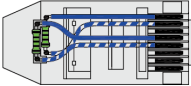
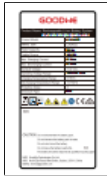
Part	Description	Part	Description
	Battery module x 1		Terminal resistor x 1 When connected to a third-party busbar, the battery needs to install this terminal resistor.
	<ul style="list-style-type: none"> <li>M5 OT terminal x 2: Recommended for connecting 10mm<sup>2</sup> cable</li> <li>M8 OT terminal x 4: Recommended for connecting 50mm<sup>2</sup> cable</li> <li>M10 OT terminal x 2: Recommended for connecting 70mm<sup>2</sup> cable</li> </ul>		M5*12 grounding screw x 2
	Mounting bracket x 2 Provided when wall-mounted installation is selected		M6*70 expansion bolt x 4 Provided when wall-mounted installation is selected
	M5*12 grounding screw x 2 Provided when wall-mounted installation is selected		Marking template x 1 Provided when wall-mounted installation is selected
	Battery bracket x 2 (optional) Provided when stacked installation is selected		M4*8 screw x 8 Provided when stacked installation is selected

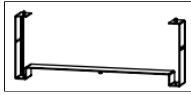

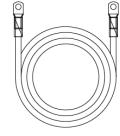
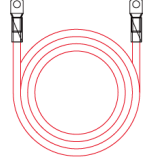
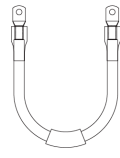
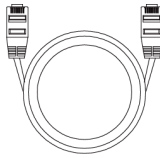
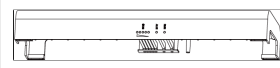
Part	Description	Part	Description
	Product documentation x 1		Negative power cable (optional) x 1
	Positive power cable (optional) x 1		Grounding cable (optional) x 1
	Communication cable (optional) x 1		Decorative cover (optional) x 1

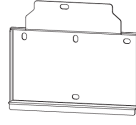

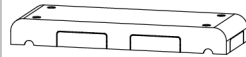
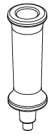
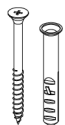

### 3.2.2.2 LX A5.0-10

Component	Description	Component	Description
	Battery Module x 1		(25-8) Power Cable OT Terminal x 4 (5.5-5) Grounding OT Terminal x 2
	M5 Grounding screw x 2		Warning Label x 1
	Terminal resistor x 1		Electrical Label x 1
	M4*8 screw x 8 (Optional) Included when bracket mounting is selected		Battery Bracket x 2 (Optional) Included when bracket mounting is selected

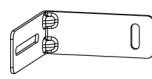
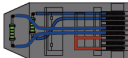
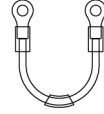

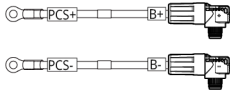
Component	Description	Component	Description
	Product Documentation x 1		Negative Power Cable (Optional) x 1
	Positive Power Cable (Optional) x 1		Grounding Cable (Optional) x 1
	Communication cable (Optional) x 1		Decorative Cover (Optional) x 1
	Wall Mount Bracket Expansion Screw (Optional) x 4		Wall Mount Bracket (Optional) x 1
	Mounting Bracket (Optional) x 1		Mounting Bracket Screw (Optional) x 4

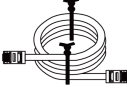
### 3.2.2.3 Batteries Deliverables (GW16.1-BAT-LV-G10)

Part	Description	Part	Description
	Battery x 1		Decorative cover x 1
	Mounting bar x 2		Expansion screw x 2
	M5*12 Hex socket screw x 7		Wall-mount anti-tip bracket x 2
	Terminal resistor x 1		Grounding wire x 1

	Positive power cable x 1 Negative power cable x 1		Decorative cover plug x 4
	Communication cable x 1		Product documentation x 1
	Quick-connect terminal release tool x 1		

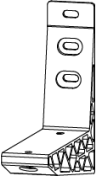
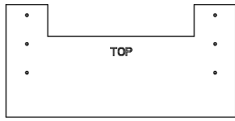

### Optional accessories

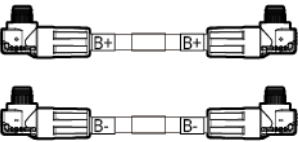
Part	Description	Part	Description
	Wall mount bracket x 2		Positioning cardboard x 1
	M10 expansion bolt x 6		M10*60 bolt x 2

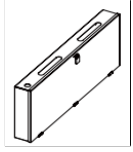

Component	Description	Component	Description
	Inter-battery cluster positive power cable x 1 Inter-battery cluster negative power cable x 1		

## 3.2.3 Combiner Box Deliverables

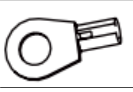

### 3.2.3.1 BCB-11-WW-0 (Optional)

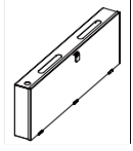
Part	Description	Part	Description
	BCB-11-WW-0 junction box x 1		M6 expansion bolt x 4
	(25-8) OT terminal x 18 (70-10) OT terminal x 2	-	-

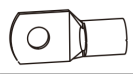
### 3.2.3.2 BCB-22-WW-0



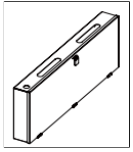

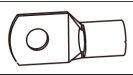

Part	Description	Part	Description
	BCB-22-WW-0 junction box x 1		M6 expansion bolt x 4
	(25-8) OT terminal x 36 (70-10) OT terminal x 6	-	-

### 3.2.3.3 BCB-32-WW-0, BCB-33-WW-0 (Optional)

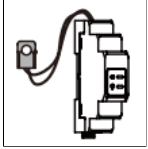
Part	Description	Part	Description
	BCB-32-WW-0, BCB-33-WW-0 combiner box x 1		M6 expansion bolt x 4
	(50-8) OT terminal x 30 (70-10) OT terminal x 6	-	-

## 3.2.4 Smart Meter Deliverables

### 3.2.4.1 GMK110

Part	Description	Part	Description
	Smart meter and CT x 1		RS485 communication terminal x 1
	Voltage input side wiring terminal x 1		PIN terminal x 4
	screwdriver x1		Product documentation x 1

## 3.3 Storage

If the equipment is not put into use immediately, store it according to the following requirements. After long-term storage, the equipment must be inspected and confirmed by qualified personnel before it can be used again.

1. If the inverter is stored for more than two years or remains idle for more than 6 months after installation, it is recommended to have it inspected and tested by qualified personnel before putting it into use.
2. To ensure the good electrical performance of the internal electronic components of the inverter, it is recommended to power it on once every 6 months during storage. If it has not been powered on for more than 6 months, it is recommended to have it inspected and tested by qualified personnel before use.
3. To ensure battery performance and service life, it is recommended to avoid long-term idle storage. Prolonged storage may cause deep discharge of the battery, leading to irreversible chemical degradation, capacity 衰减, or even complete failure. It is recommended to use the battery promptly. If the battery requires long-term storage, please maintain it according to the following requirements:

Battery Model	Initial SOC Range for Storage	Recommended Storage Temperature	Charge/Discharge Maintenance Cycle <sup>[1]</sup>	Battery Maintenance Method <sup>[2]</sup>
LX A5.0-10	30%~40%	0~35°C	-20~0°C, ≤1 month	Please consult the dealer or after-sales service center for maintenance methods.
n*LX A5.0-10			0~35°C, ≤6 months	
LX A5.0-30	30%~40%	0~35°C	-20~45°C, ≤6 months	
GW16.1-BAT-LV-G10	30%~40%	0~35°C	-20~35°C, ≤12 months 35~45°C, ≤6 months	

### NOTICE

[1] The storage time is calculated from the SN date on the battery's outer packaging. Charge/discharge maintenance is required after exceeding the storage period. (Battery maintenance time = SN date + charge/discharge maintenance cycle). For the method to view the SN date, refer to: [SN Encoding Meaning](#).

[2] After passing the charge/discharge maintenance, if the outer box has a Maintaining Label, please update the maintenance information on the Maintaining Label. If there is no Maintaining Label, please record the maintenance time and battery SOC yourself and keep the data securely for maintaining maintenance records.

#### **Packaging Requirements:**

Ensure the outer packaging box is not removed and the desiccant inside the box is not missing.

#### **Environmental Requirements:**

1. Ensure the equipment is stored in a cool place, avoiding direct sunlight.
2. Ensure the storage environment is clean, with appropriate temperature and humidity ranges, and free from condensation. If condensation is observed on the equipment ports, do not install the equipment.
3. Ensure the equipment is stored away from flammable, explosive, corrosive, and other hazardous materials.

**Stacking Requirements:**

1. Ensure the stacking height and orientation of the inverter comply with the instructions on the packaging box label.
2. Ensure there is no risk of the inverter stack tipping over.

# 4 Installation



When performing device installation and electrical connections, please use the delivery items shipped with the box. Otherwise, any resulting device damage will not be covered under warranty.

## 4.1 System Installation and Commissioning Procedure

Steps	1 Installation	2 PE	3 PV	4 Battery	5 AC	6 COM
Inverter						
Tools	D: 80mm Φ: 8mm	M5 1.5-2N-m		1 M8 5N-m 2 M25 5-6N-m	1 1.5N-m 2 M25 5-6N-m 3 M22 5N-m	1 M2 0.2-0.3N-m 2 M22 5N-m 3 M25 5-6N-m

Steps	1 Installation						2 PE	3 Battery		4 COM
Battery	LX A5.0-10			LX A5.0-30			LX A5.0-10 LX A5.0-30	LX A5.0-10	LX A5.0-30	LX A5.0-10 LX A5.0-30
Tools			1 D: 80mm Φ: 8mm 2 3			1 D: 80mm Φ: 8mm 2 3	M5 4N-m	M6 6N-m	M8 12N-m	
	M4 1.4N-m	M6 6N-m	2 M6 6N-m 3 M5 4N-m	M4 1.4N-m	M6 6N-m	2 M6 6N-m 3 M4 1.4N-m				

EO20INT010

Steps	1 Installation		2 PE	3 Battery	4 COM
Battery	GW16.1-BAT-LV-G10		GW16.1-BAT-LV-G10	GW16.1-BAT-LV-G10	GW16.1-BAT-LV-G10
Tools			M5 4N-m		
Steps	1 Installation	2 Cable Connections	3 Power	4 Commissioning	
Smart meter	GMK110	GMK110	AC breaker		

EO20INT0012

## 4.2 Installation Requirements

### 4.2.1 Installation Environment Requirements

1. The equipment must not be installed in flammable, explosive, corrosive, or similar environments.
2. The temperature and humidity of the installation environment must be within a suitable range.
3. The installation location must be out of reach of children and avoid easily accessible positions.
4. The enclosure temperature of the Inverter may exceed 60°C during operation. Do not touch the enclosure before it has cooled down to prevent burns.
5. The equipment must be installed away from direct sunlight, rain, snow accumulation, and similar conditions. It is recommended to install in a sheltered location; if necessary, build a sunshade.
6. Adverse environmental conditions such as direct sunlight and high temperatures may cause output power derating of the Inverter.
7. The installation space must meet the equipment's ventilation, heat dissipation, and operational space requirements.
8. The installation environment must satisfy the equipment's ingress protection rating. The Inverter, battery, and smart communication stick are suitable for indoor and outdoor installation; the meter is suitable for indoor installation only.
9. The equipment installation height should facilitate operation and maintenance, ensuring equipment indicator lights, all labels are easily visible, and wiring terminals are easy to operate.

10. The installation altitude of the equipment must be lower than the maximum operating altitude.
11. For outdoor installation in salt damage areas, consult the equipment manufacturer. Salt damage areas mainly refer to regions within 500m of the coast. The affected area is related to sea wind, precipitation, terrain, and other conditions.
12. Keep away from strong magnetic field environments to avoid electromagnetic interference. If there are radio stations or wireless communication devices below 30MHz near the installation location, install the equipment according to the following requirements:
  - Inverter: Add a ferrite core with multiple windings at the DC input or AC output lines of the Inverter, or add a low-pass EMI filter; or ensure the distance between the Inverter and the wireless electromagnetic interference device exceeds 30m.
  - Other equipment: Ensure the distance between the equipment and the wireless electromagnetic interference device exceeds 30m.
13. The length of the DC cable and communication cable between the battery and the Inverter must be less than 3m. Ensure the installation distance between the Inverter and the battery meets the cable length requirement.

#### NOTICE

If installed in an environment below 0°C, the battery will be unable to recharge and restore energy once depleted, resulting in battery undervoltage protection.

- LX A5.0-30, GW16.1-BAT-LV-G10: Charging temperature range:  $0 < T \leq 55^{\circ}\text{C}$ ; Discharging temperature range:  $-20 < T \leq 55^{\circ}\text{C}$
- LX A5.0-10: Charging temperature range:  $0 < T \leq 50^{\circ}\text{C}$ ; Discharging temperature range:  $-10 < T \leq 50^{\circ}\text{C}$

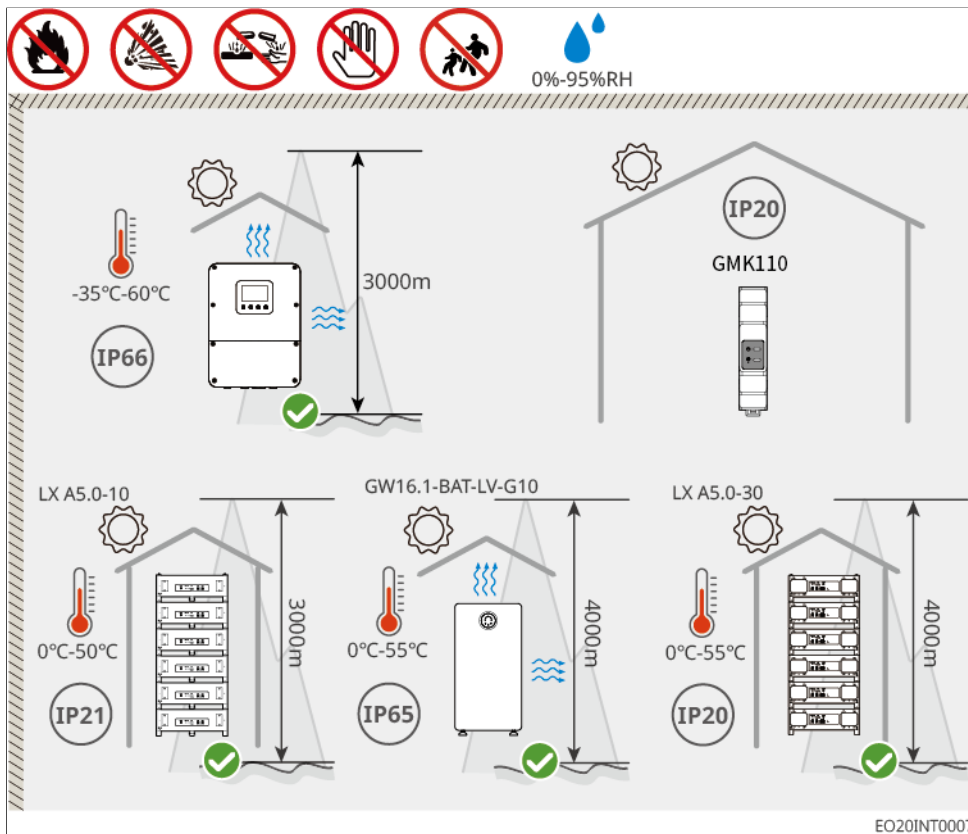

Figure4 Installation Environment Requirements

## 4.2.2 Installation Space Requirements

When installing equipment in the system, sufficient space should be reserved around the equipment to ensure adequate installation and heat dissipation space.

- Installation of CT requires the use of CAT5E or higher grade shielded network cable, with a cable distance not exceeding 30 meters.
- The RS485 twisted-pair shielded cable for communication between the inverter and the meter should have a cable distance not exceeding 100 meters.

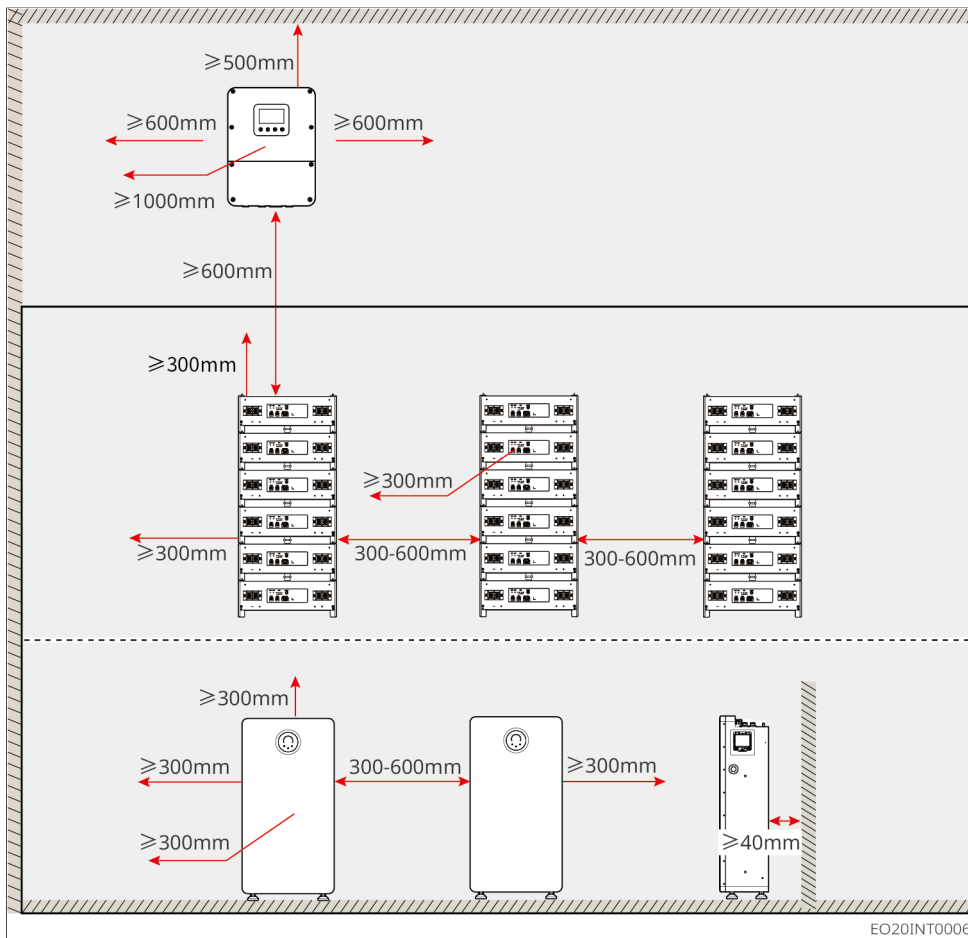

Figure5 Installation distance requirements

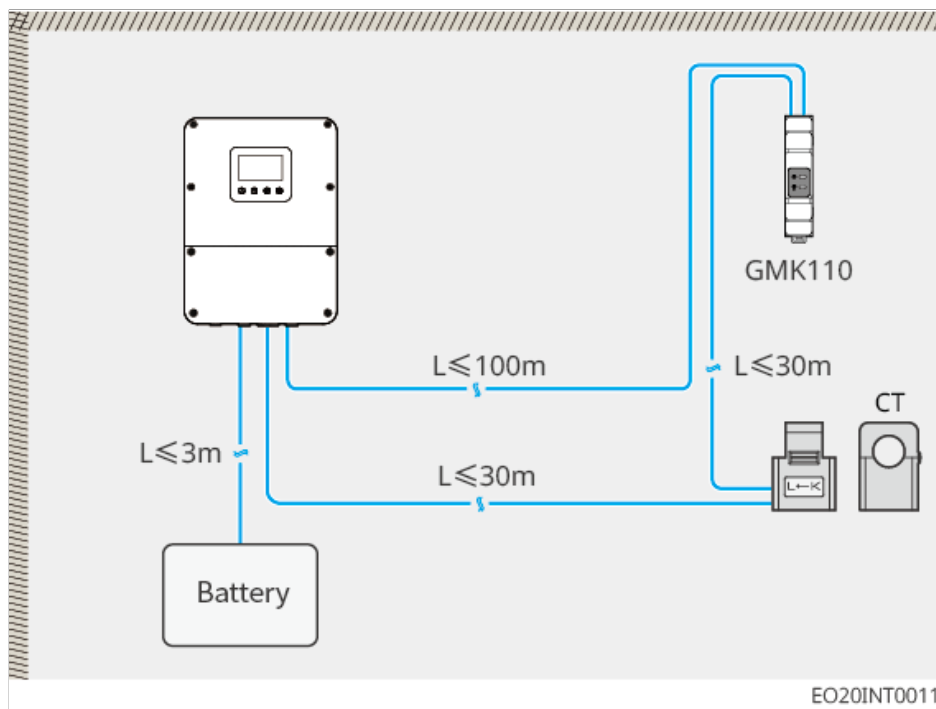





Figure6 Cable length requirements









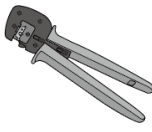
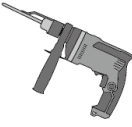
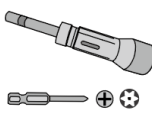

### 4.2.3 Tool Requirements

**NOTICE**

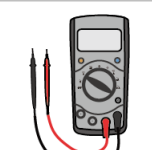
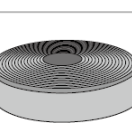

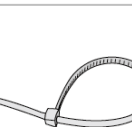
During installation, it is recommended to use the following installation tools. If necessary, other auxiliary tools may be used on-site.

#### Installation Tools

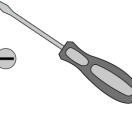
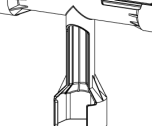
Tool Type	Description	Tool Type	Description
	diagonal plier		RJ45 connector crimping tool
	wire stripper		Level bar

Tool Type	Description	Tool Type	Description
	open-end wrench		PV terminal crimping tool A-2546B
	hammer drill (Bit Φ8mm)		torque wrench M2, M5, M6, M8
	rubber hammer		socket wrench
	Marker pen		multimeter Range ≤600V
	Heat shrink tubing		Heat gun
	cable tie		Vacuum cleaner
	Flat-head screwdriver		Cable gland unlocking tool Note: Please contact your distributor or GoodWe for purchase if needed.
	Inverter battery cable crimping tool HS-95WF		Hex key M16, M8

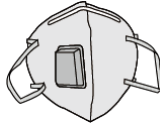
personal protective equipment

Tool Type	Description	Tool Type	Description
	Insulating gloves, protective gloves		Dust mask
	goggle		Safety shoes

## 4.3 Equipment Handling

### CAUTION

1. During operations such as transportation, handling, and installation, all applicable laws, regulations, and relevant standard requirements of the country/region must be met.
2. Before installation, the equipment must be moved to the installation site. To avoid personal injury or equipment damage during handling, please note the following:
  - a. Ensure an adequate number of personnel is assigned according to the equipment weight to prevent injuries caused by the equipment exceeding the human lifting capacity.
  - b. Wear safety gloves to prevent injury.
  - c. Ensure the equipment remains balanced during handling to avoid dropping.
  - d. The battery system can be removed from the packaging and transported to the installation site using a crane or lifting method.
    - Crane requirement GW16.1-BAT-LV-G10: Lifting capacity  $\geq 180\text{kg}$ .
    - When using lifting methods to move the equipment, please use flexible slings or straps. Requirements for lifting lugs and slings for GW16.1-BAT-LV-G10: Lifting lugs: 4 x M10 lugs, each with a load capacity  $\geq 260\text{ kg}$ ; Sling: 1 piece, length  $\geq 2.5\text{m}$ , load capacity  $\geq 600\text{kg}$ .

## 4.4 Installing the Inverter

## ⚠ CAUTION

- When drilling holes, ensure the drilling location avoids water pipes, cables, etc., inside the wall to prevent hazards.
- When drilling, please wear safety goggles and a dust mask to avoid inhaling dust into the respiratory tract or getting it into the eyes.
- Ensure the inverter is securely installed to prevent it from falling and causing injury.

1. Place the back mounting plate horizontally on the wall, and use a marker pen to mark the drilling positions.
2. Use an impact drill to drill the holes.
3. Use expansion screws to fix the inverter back mounting plate bracket to the wall.
4. Hang the inverter on the back plate. After hanging, install the anti-theft lock.

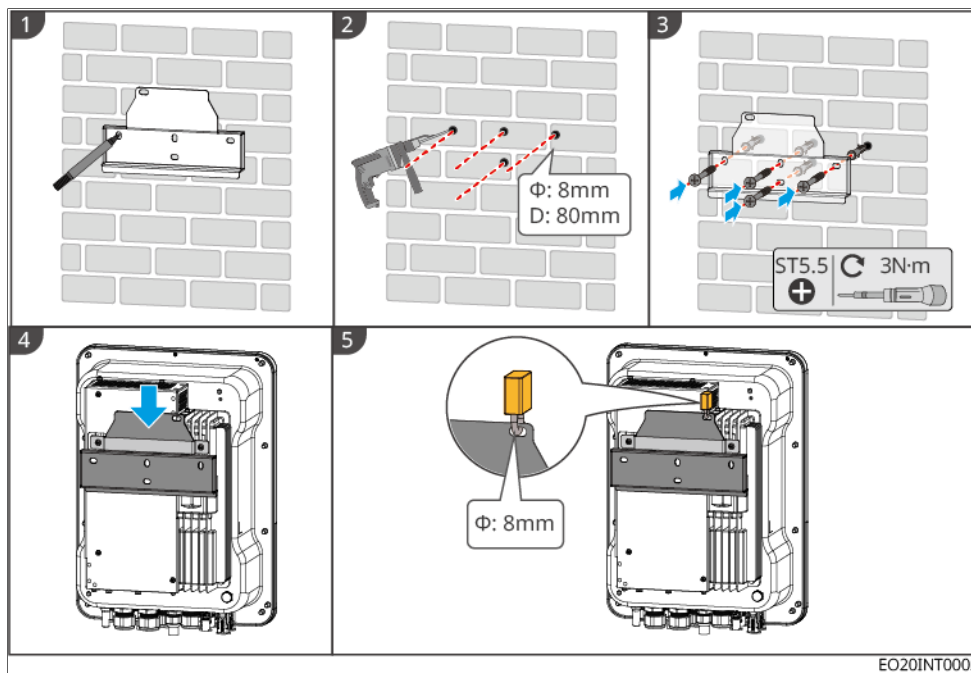

Figure7 Installing the Inverter

## 4.5 Installing the Battery System

### ⚠ WARNING

- When installing the battery system, ensure that it is level and secure. When using an anti-tipping bracket, the bracket should be vertically flush against the wall and the surface of the battery system.
- When using an impact drill to make holes, use cardboard or other coverings to shield the battery system to prevent foreign objects from entering the device and causing damage.
- After marking the drilling positions with a marker pen, move the battery system away to prevent the impact drill from being too close to the battery system during drilling, which could cause damage to the device.

### 4.5.1 LX A5.0-30

#### LX A5.0-30: Floor Stacking

#### NOTICE

Floor stacking supports a maximum of 6 batteries stacked

1. Place the battery vertically and remove the battery handle.
2. Install the bracket on the battery and secure it with screws.
3. Lay the battery flat and stack multiple batteries for installation. Ensure the locating pins are inserted into the locating holes.

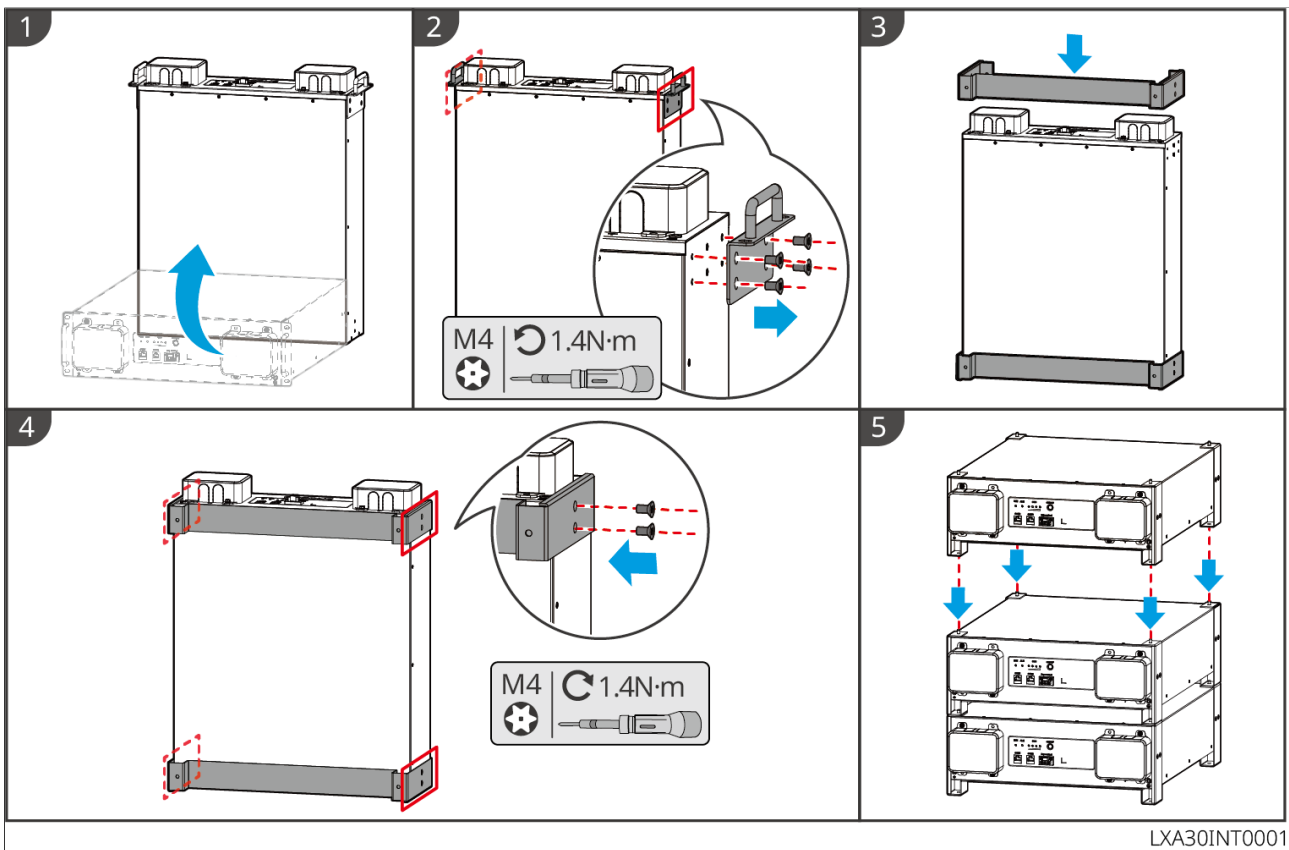

## LX A5.0-30: Cabinet Installation

### NOTICE

- Recommended to be installed in a 19-inch standard cabinet, length\*width: 600\*800mm and above, height: select based on the battery thickness (133mm) and above.
- For cabinet installation, it is necessary to paste electrical labels and warning labels on the front panel of any battery (these labels are shipped as additional accessories).

1. Place the battery onto the rails inside the cabinet, and secure the battery to the cabinet with screws through the handle.

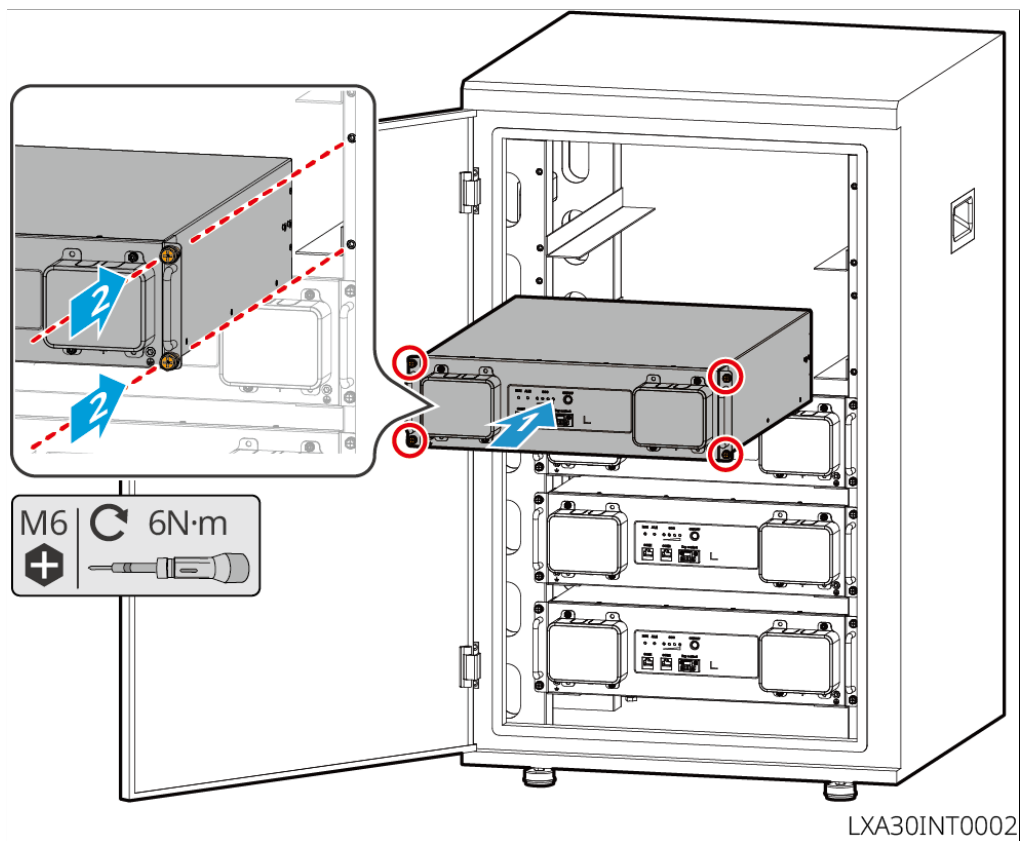

### LX A5.0-30: Wall Mounting

1. Determine the drilling positions according to the marking template, and mark the drilling spots with a marker pen.
2. Drill holes using an impact drill.
3. Install the battery wall bracket.
4. Mount the battery onto the bracket, and securely connect the battery and the bracket with screws.

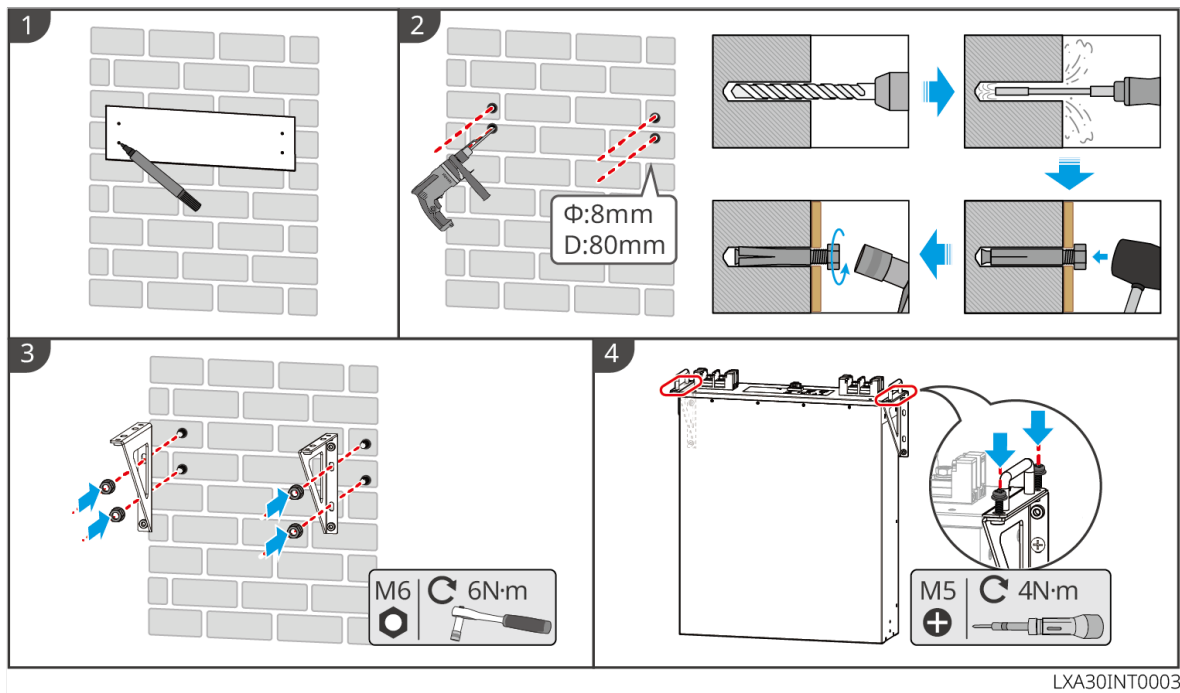

LXA30INT0003

## 4.5.2 LX A5.0-10

### LX A5.0-10: Floor Stacking

#### NOTICE

A maximum of 6 batteries can be stacked in floor stacking.

1. Place the battery vertically.
2. Place the bracket onto the battery and remove the handle from the battery.
3. Place the other bracket onto the battery.
4. Secure the brackets to the battery with screws and lay the battery flat.
5. Stack and install multiple batteries.
  - Align the locating pins on the lower battery bracket with the locating holes on the upper battery bracket, and insert the pins into the holes.

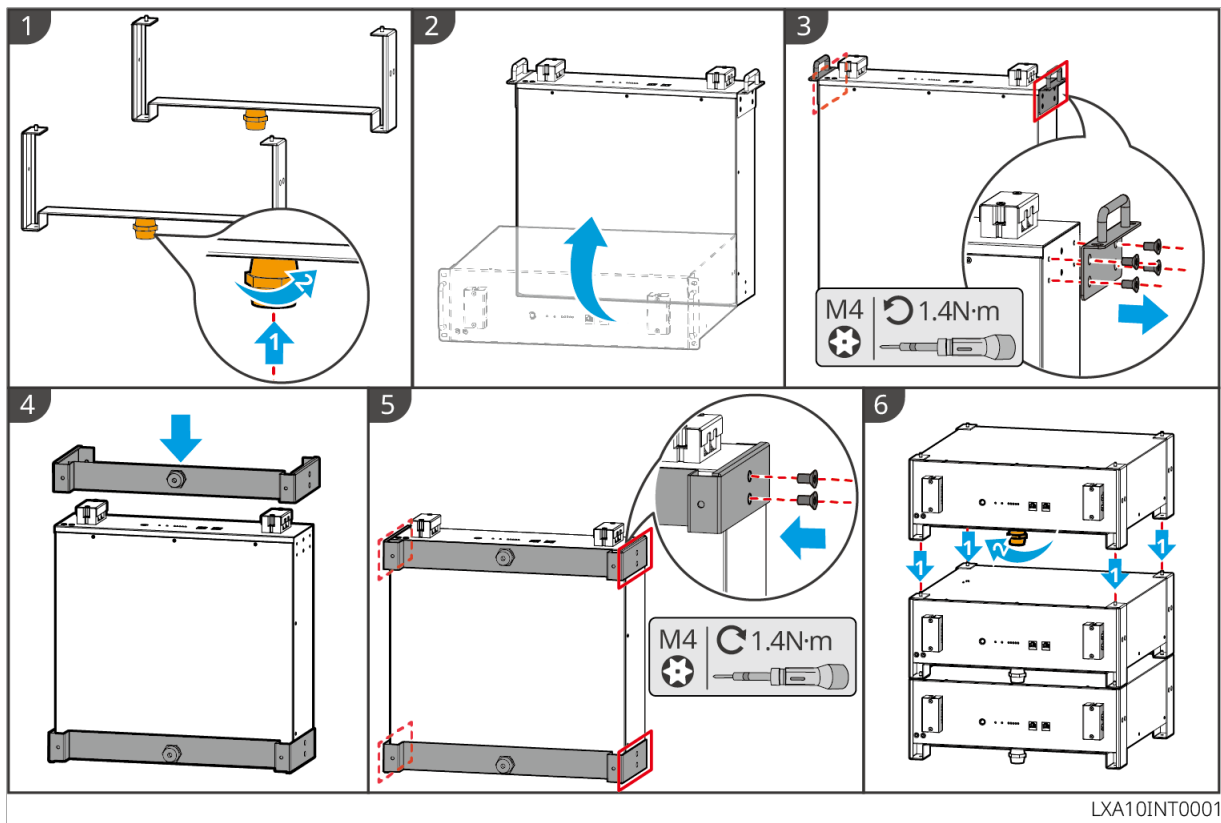

## LX A5.0-10: Cabinet Installation

### NOTICE

- Recommended 19-inch standard cabinet, physical length and width can be selected as 600\*800mm or above, height can be chosen according to the number of battery parallel connections.
- Cabinet installation requires attaching electrical labels and warning labels on the front panel of any battery (these labels are shipped as additional accessories).

1. Attach the electrical label and warning label to any position on the front panel of a battery.
2. Place the battery onto the cabinet rails and secure the battery to the cabinet with screws through the handle.

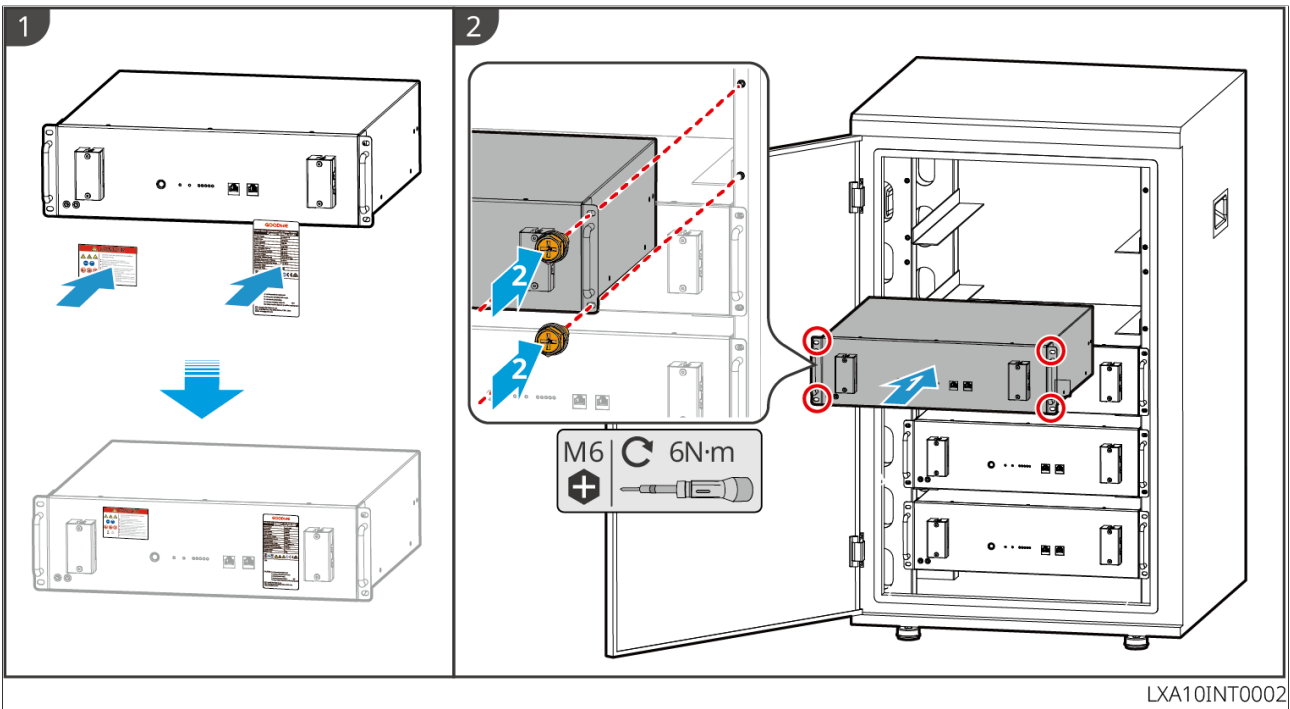

### LX A5.0-10: Wall Mount Installation

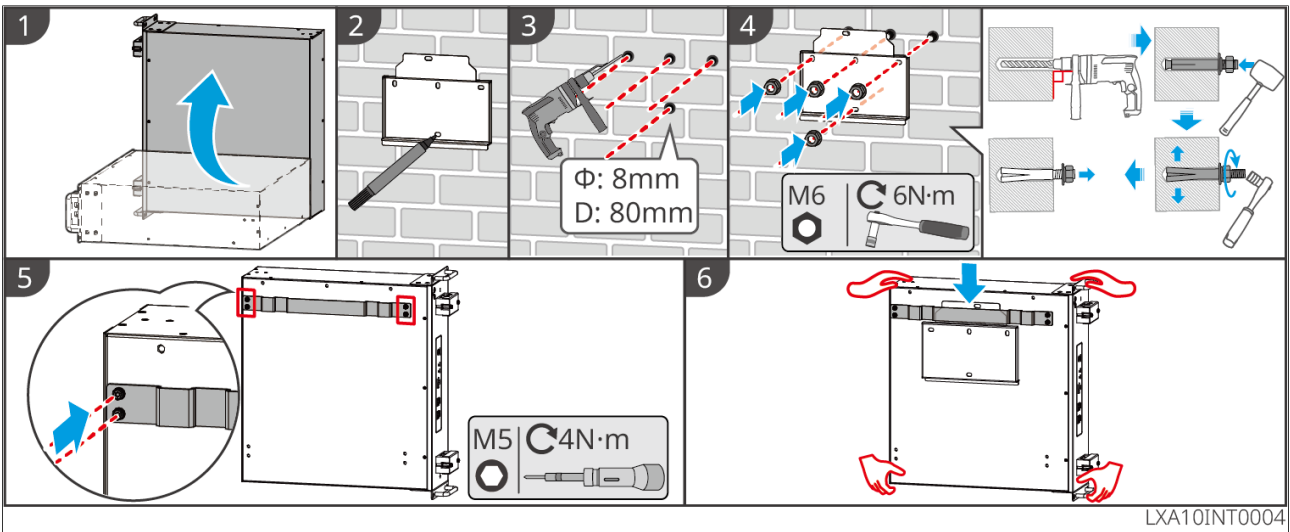

### 4.5.3 GW16.1-BAT-LV-G10

#### NOTICE

- Wall mounting requires two-person installation.

## Floor-mounted Installation

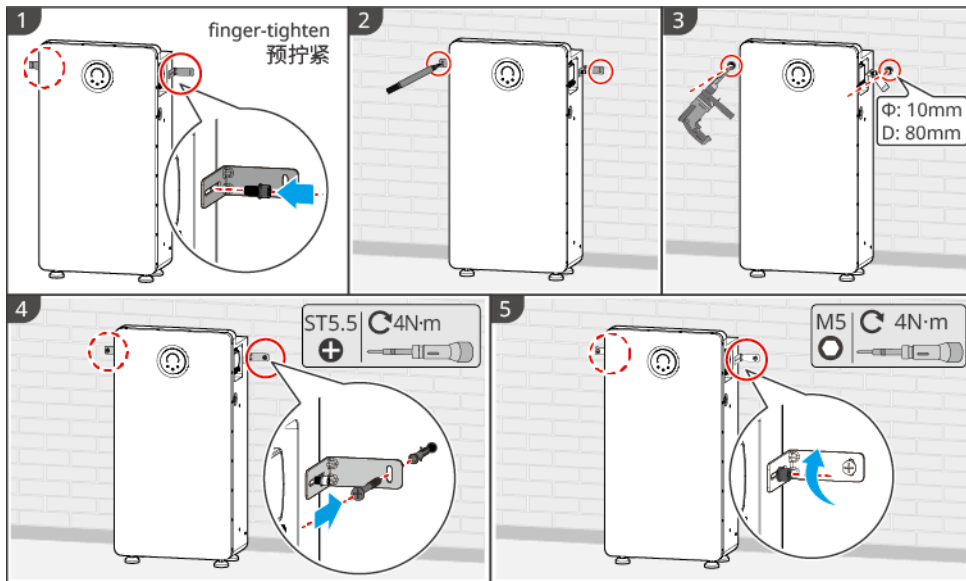

LXA40INT0002

## Wall-mounted Installation

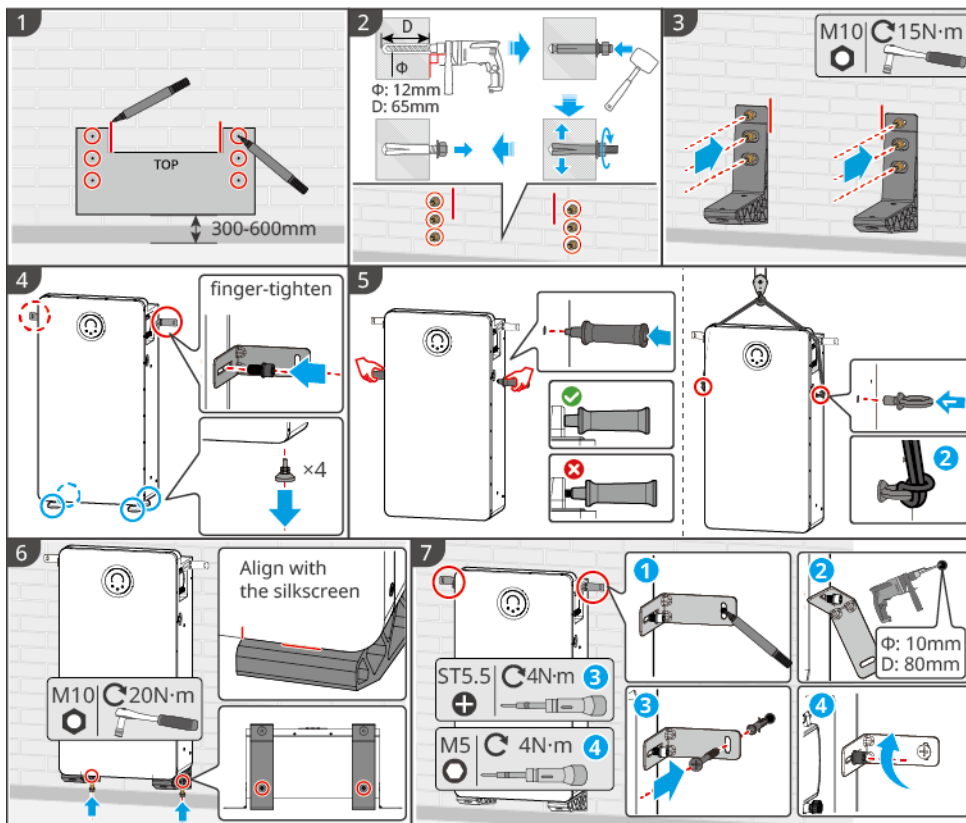

LXA40INT0003

## 4.6 Installing the Smart Meter

**⚠ WARNING**

In areas at risk of lightning, if the meter cable length exceeds 10m and the cable is not routed using a grounded metal conduit, it is recommended to install external lightning protection devices.

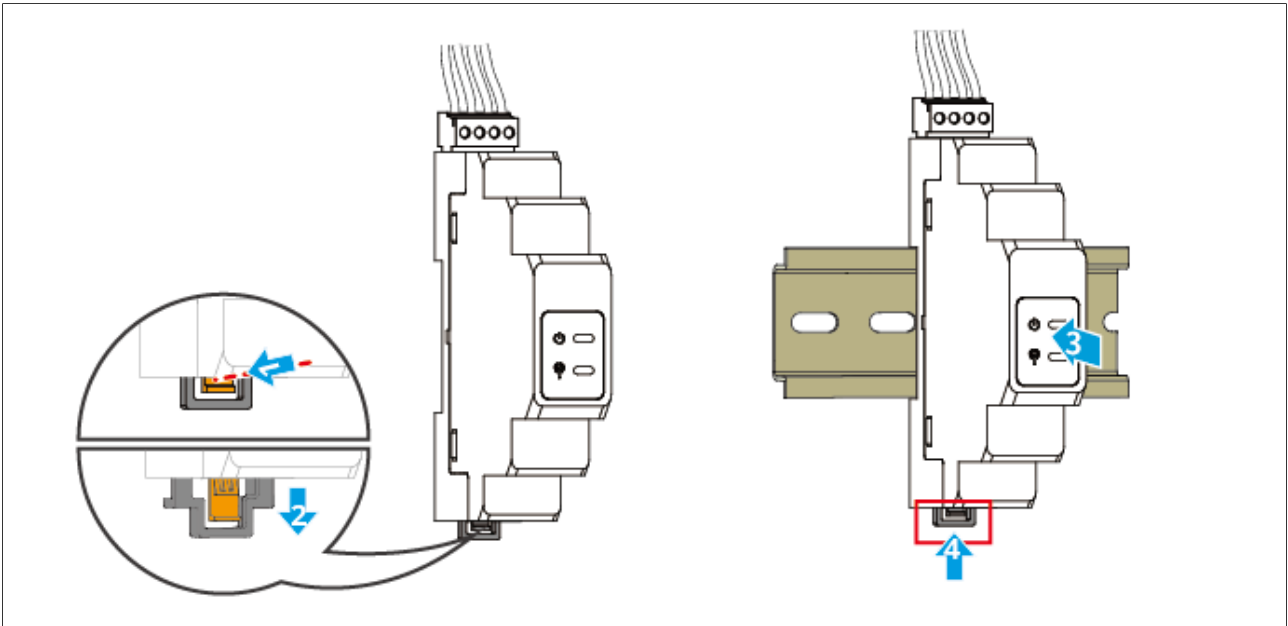

Figure8 Installing GMK110

# 5 System Wirings

## DANGER

- The installation, routing, and connection of cables must comply with local laws, regulations, and standard requirements.
- All operations during electrical connection, as well as the specifications of cables and components used, must meet local legal and regulatory requirements.
- Before performing electrical connections, disconnect the DC switch and AC output switch of the equipment to ensure it is powered off. Live working is strictly prohibited, otherwise, hazards such as electric shock may occur.
- Cables of the same type should be bundled together and arranged separately from different types of cables. Intertwining or crossing arrangements are prohibited.
- If the cable is subjected to excessive tension, poor connections may result. When connecting, leave a certain length of cable slack before connecting it to the inverter terminal ports.
- When crimping terminal lugs, ensure the conductor part of the cable makes full contact with the lug. Do not crimp the cable insulation together with the lug. Otherwise, it may cause equipment malfunction or, after operation, lead to issues such as heating due to unreliable connections, potentially damaging the inverter terminal block.

## NOTICE

- When performing electrical connections, wear personal protective equipment such as safety shoes, protective gloves, and insulating gloves as required.
- Only qualified personnel are permitted to perform electrical connection operations.
- The cable colors shown in the figures in this document are for reference only. Specific cable specifications must comply with local regulatory requirements.
- For parallel systems, please observe the safety precautions in the user manuals corresponding to the relevant products within the system.

## 5.1 System Wiring Electrical Block Diagram

### NOTICE

- Depending on regional regulatory requirements, the wiring methods for the N line and PE line of the inverter's ON-GRID and BACK-UP ports differ. Please follow the specific local regulations.
- The inverter's ON-GRID AC port has a built-in relay. When the inverter is in off-grid mode, the built-in ON-GRID relay is open; when the inverter is in grid-connected mode, the built-in ON-GRID relay is closed.
- After the inverter is powered on, the BACK-UP AC port is live. If maintenance is required on the BACK-UP Loads, please de-energize the inverter; otherwise, electric shock may occur.

N and PE lines are separately wired in the distribution box.

### NOTICE

- Please ensure that the protective ground wire of BACK-UP is connected correctly and securely, otherwise the BACK-UP function may malfunction when a grid fault occurs.
- Other regions except Australia, New Zealand, etc. are applicable to the following wiring methods:

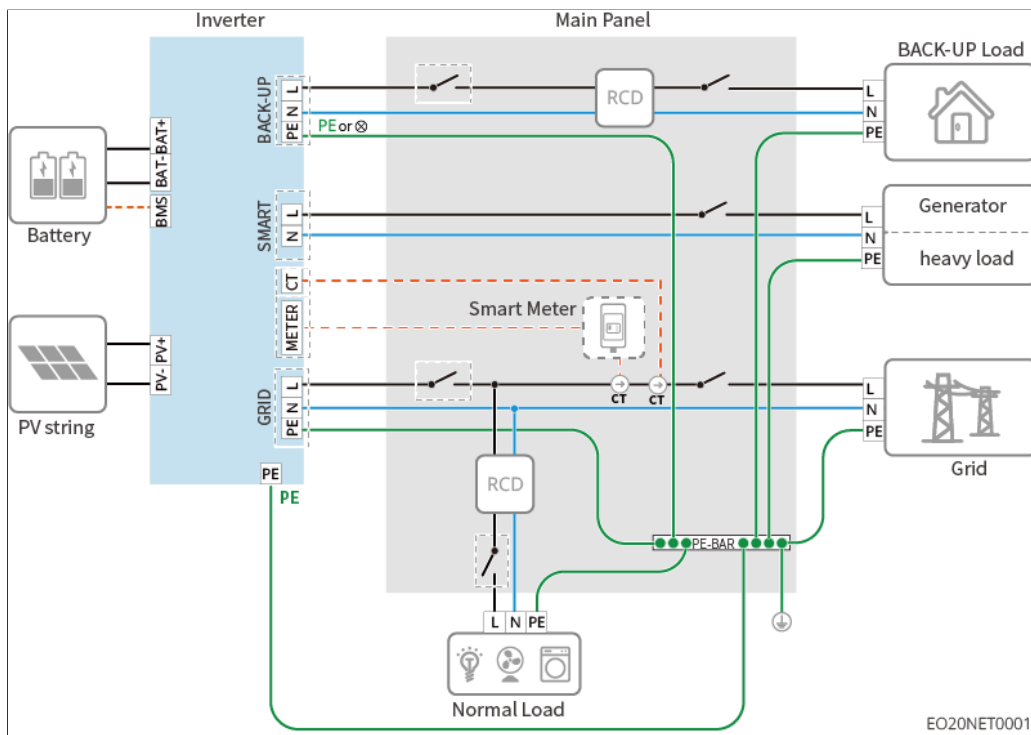

Figure9 Except for regions such as Australia, New Zealand, etc.

## 5.2 Detailed System Wiring Diagram

### 5.2.1 Detailed System Wiring Diagram for Single Inverter

#### Whole House Backup Scenario

Whole house backup refers to the ability of the energy storage system to seamlessly take over all loads when the power grid fails, providing continuous and stable power supply to the entire house, ensuring all electrical equipment is unaffected by grid fluctuations.

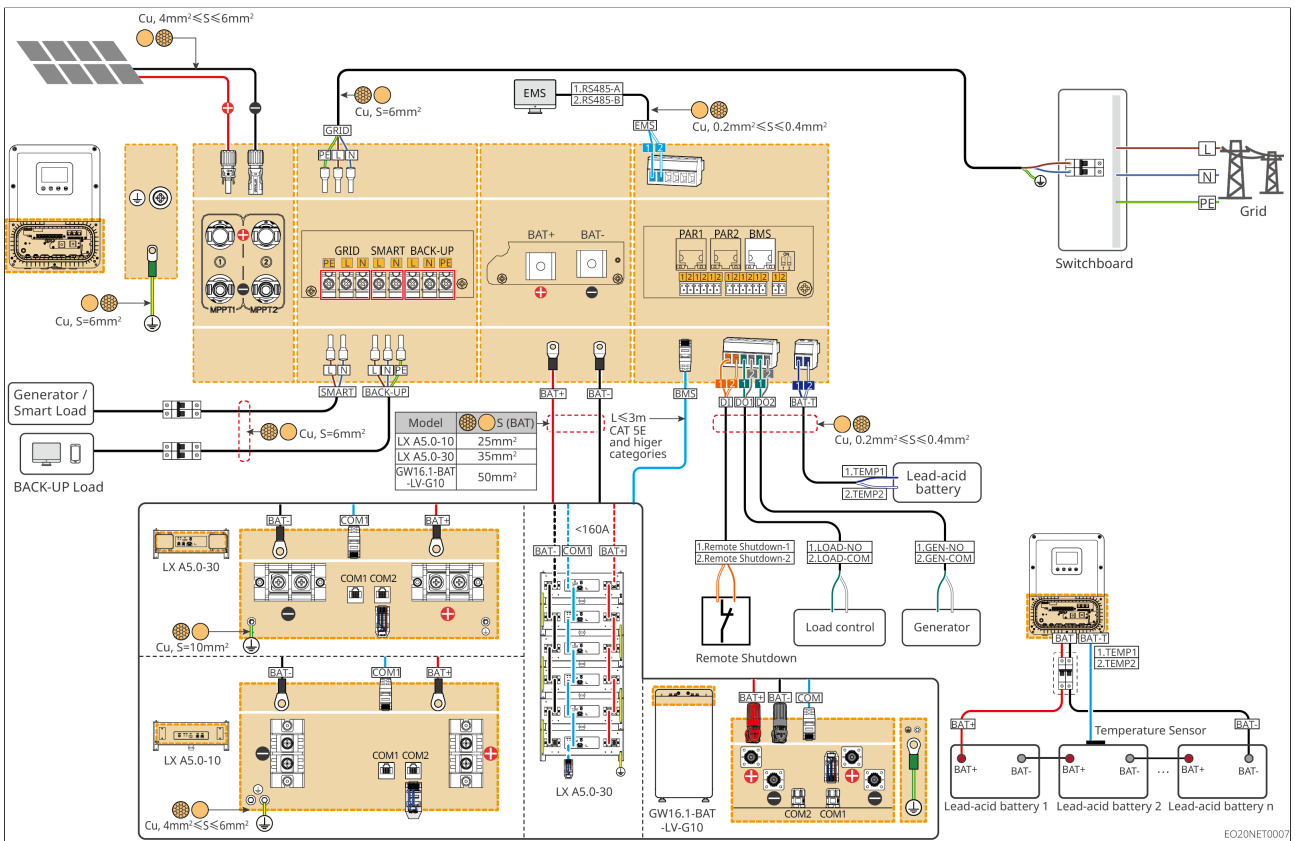

Figure10 Whole House Backup Scenario

### Partial Backup Scenario

Partial backup refers to a scenario where, during a grid power outage, the energy storage system only guarantees the operation of loads connected to the backup (BACK-UP) and smart (SMART) ports, while loads connected to the grid (GRID) side will not function. To achieve precise management and scheduling of loads, the system requires an external CT or smart meter to monitor the power consumption of grid-side loads in real-time.

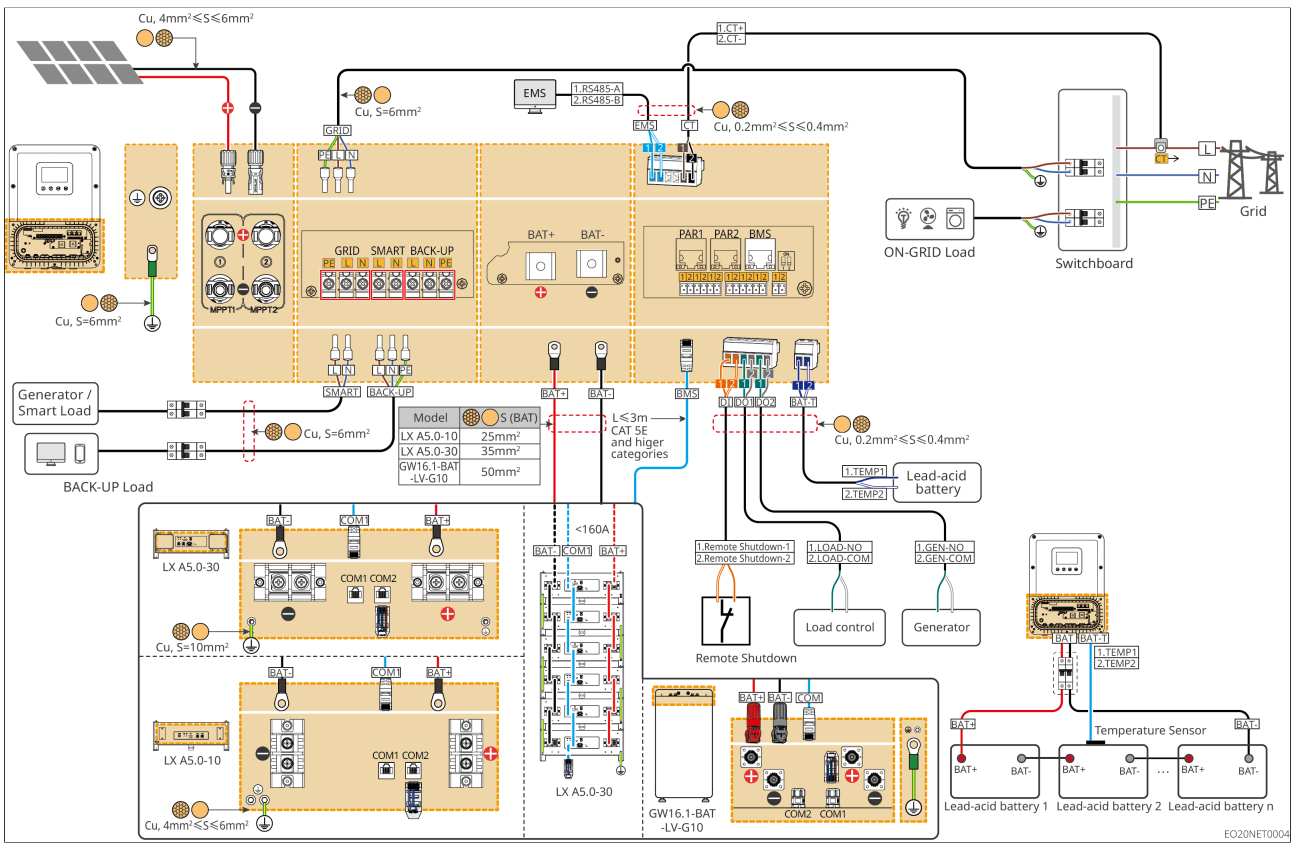

Figure11 Partial Backup Scenario with CT

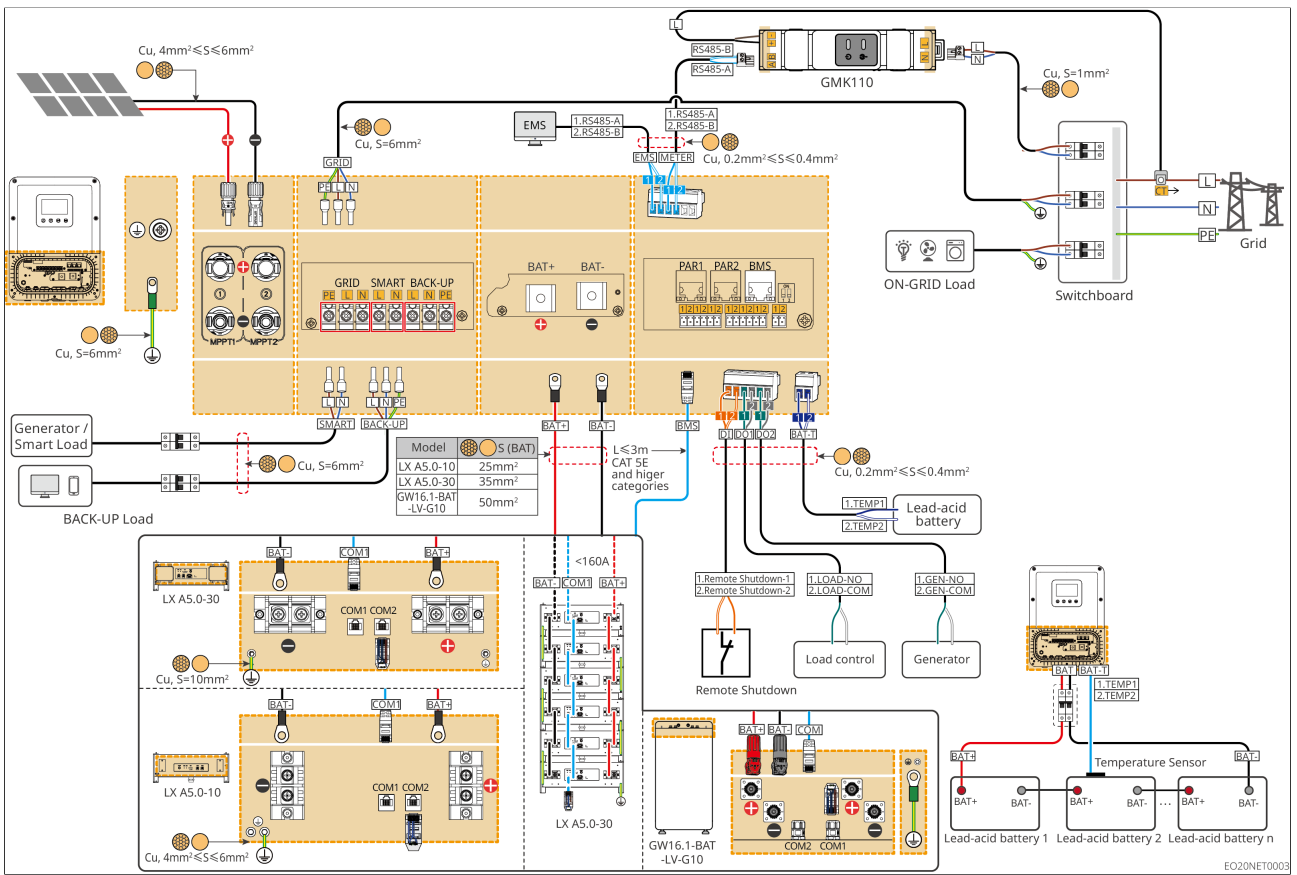

Figure12 Partial Backup Scenario with GMK110

## 5.3 Preparing Materials

**!WARNING**

- Do not connect loads between the inverter and the AC switch directly connected to the inverter.
- Each inverter must be equipped with an AC output circuit breaker. Multiple inverters must not be connected to one AC circuit breaker simultaneously.
- To ensure the inverter can safely disconnect from the grid in case of an abnormality, please connect an AC circuit breaker on the AC side of the inverter. Select a suitable AC circuit breaker according to local regulations.
- When the inverter is powered on, the BACK-UP AC port is live. If maintenance is required on the BACK-UP Loads, power down the inverter; otherwise, electric shock may occur.
- For cables used in the same system, ensure the conductor material, cross-sectional area, length, etc., of the power cables between batteries are consistent.

### 5.3.1 Preparing Breakers

No.	breaker	Recommended Specifications	Remarks
1	<ul style="list-style-type: none"><li>• ON-GRID breaker</li><li>• BACK-UP Loads breaker</li><li>• SMART breaker</li></ul>	<ul style="list-style-type: none"><li>• GW3K-EO-G20, GW3.6K-EO-G20: Rated Current <math>\geq 40A</math>, Nominal Voltage <math>\geq 230V</math></li><li>• GW5K-EO-G20, GW6K-EO-G20: Rated Current <math>\geq 50A</math>, Nominal Voltage <math>\geq 230V</math></li></ul>	Self-provided

No.	breaker	Recommended Specifications	Remarks
2	Battery Switch	<p>Select according to local laws and regulations</p> <ul style="list-style-type: none"> <li>• GW3K-EO-G20: Rated Current <math>\geq 90A</math>, Nominal voltage <math>\geq 60V</math></li> <li>• GW3.6K-EO-G20: Rated Current <math>\geq 115A</math>, Nominal Voltage <math>\geq 60V</math></li> <li>• GW5K-EO-G20: Rated Current <math>\geq 150A</math>, Nominal Voltage <math>\geq 60V</math></li> <li>• GW6K-EO-G20: Rated Current <math>\geq 175A</math>, Nominal Voltage <math>\geq 60V</math></li> </ul>	Self-provided
3	RCD	<p>RCD Device Installation and RCD Specification Selection:</p> <p>It is recommended to externally connect a Type A RCD with a residual current trigger level <math>\geq 300mA</math> on the AC output side of the inverter (for inverter capacity <math>&lt; 30kVA</math>, select a residual current operating level of <math>300mA</math>; for inverter capacity <math>\geq 30kVA</math>, select a residual current operating level of <math>10mA/kVA</math>). Alternatively, select the appropriate RCD specification according to local regulatory requirements.</p>	Self-provided

### 5.3.2 Preparing Cables

No.	Cable	Recommended Specifications	Acquisition Method
1	Inverter Protective Ground Cable	<ul style="list-style-type: none"> <li>• Single-core outdoor copper cable</li> <li>• Conductor cross-sectional area: <math>S=6mm^2</math></li> </ul>	Self-provided

No.	Cable	Recommended Specifications	Acquisition Method
2	Battery Protective Ground Cable	<ul style="list-style-type: none"> <li>• Single-core outdoor copper cable</li> <li>• Conductor cross-sectional area:               <ul style="list-style-type: none"> <li>• LX A5.0-10: 4-6mm<sup>2</sup></li> <li>• LX A5.0-30: 10mm<sup>2</sup></li> <li>• GW16.1-BAT-LV-G10: 10mm<sup>2</sup></li> </ul> </li> </ul>	<ul style="list-style-type: none"> <li>• LX A5.0-30, LX A5.0-10: Obtained from accessories (optional)</li> <li>• GW16.1-BAT-LV-G10: Obtained from accessories (standard-equipped)</li> </ul>
3	PV DC Cable	<ul style="list-style-type: none"> <li>• Industry-standard outdoor photovoltaic cable</li> <li>• Conductor cross-sectional area: 4-6mm<sup>2</sup></li> <li>• Cable outer diameter: 4mm-7mm</li> </ul>	Self-provided
4	Battery DC Cable	<ul style="list-style-type: none"> <li>• Single-core outdoor copper cable</li> <li>• Inverter battery port connection requirements:               <ul style="list-style-type: none"> <li>◦ Conductor cross-sectional area: 25-35mm<sup>2</sup></li> <li>◦ Cable outer diameter: 8-13mm</li> </ul> </li> <li>• Cable requirements between batteries:               <ul style="list-style-type: none"> <li>◦ LX A5.0-10, conductor cross-sectional area: 25mm<sup>2</sup></li> <li>◦ LX A5.0-30, conductor cross-sectional area: 50mm<sup>2</sup></li> <li>◦ GW16.1-BAT-LV-G10, conductor cross-sectional area: 50mm<sup>2</sup></li> </ul> </li> </ul>	<ul style="list-style-type: none"> <li>• LX A5.0-30, LX A5.0-10: Obtained from accessories (optional)</li> <li>• GW16.1-BAT-LV-G10: Obtained from accessories (standard-equipped)</li> </ul>

No.	Cable	Recommended Specifications	Acquisition Method
5	AC Cable	<ul style="list-style-type: none"> <li>• Inverter AC input/output cable (BACK-UP/GRID):               <ul style="list-style-type: none"> <li>◦ Conductor cross-sectional area: 6mm<sup>2</sup></li> <li>◦ Multi-core outdoor copper cable outer diameter: 14-16mm</li> </ul> </li> <li>• SMART cable:               <ul style="list-style-type: none"> <li>◦ Conductor cross-sectional area: 6mm<sup>2</sup></li> <li>◦ Multi-core outdoor copper cable outer diameter: 13mm-15mm</li> </ul> </li> </ul>	Self-provided
6	Smart Meter Power Cable	<ul style="list-style-type: none"> <li>• Outdoor copper cable</li> <li>• Conductor cross-sectional area: 1mm<sup>2</sup></li> </ul>	Self-provided
7	Battery Communication Cable	Communication between batteries requires the use of CAT 5E or higher standard shielded network cable and RJ45 shielded connectors.	<ul style="list-style-type: none"> <li>• Self-provided</li> <li>• LX A5.0-10, LX A5.0-30: Obtained from accessories (optional)</li> </ul>
8	Meter RS485 Communication Cable	<ul style="list-style-type: none"> <li>• Shielded twisted pair</li> <li>• Conductor cross-sectional area: 0.2mm<sup>2</sup>-0.4mm<sup>2</sup></li> </ul>	Self-provided
9	DO/DI/CT Communication Cable	<ul style="list-style-type: none"> <li>• Copper twisted pair</li> <li>• Conductor cross-sectional area: 0.2mm<sup>2</sup>-0.4mm<sup>2</sup></li> </ul>	Self-provided

## 5.4 Removing the Inverter Enclosure Lower Cover

## NOTICE

- Use the specified tool (wrench) to open the inverter lower enclosure cover. Properly store the removed cover, wrench, and fastening screws for subsequent reinstallation.
- It is prohibited to open the cover during rainy or snowy weather. If it is absolutely necessary to open it under special circumstances, reliable protective measures (such as setting up a temporary rain shelter) must be taken to ensure that rain or snow does not enter the maintenance cavity; otherwise, the operation is strictly forbidden.
- It is prohibited to open the inverter upper enclosure cover.

Remove the inverter enclosure lower cover:

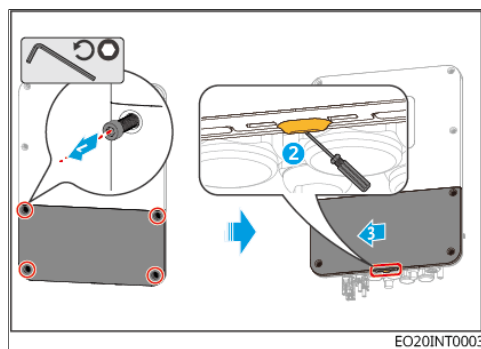

Figure13 Removing the lower cover

(Optional) Using the cable gland unlocking tool:

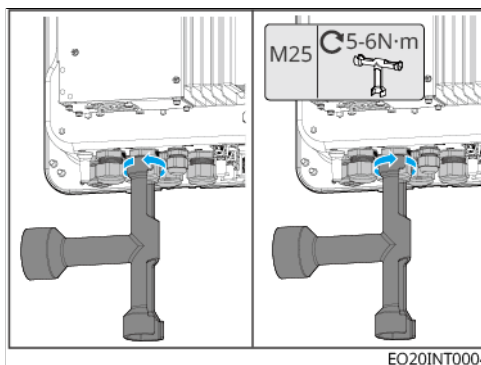
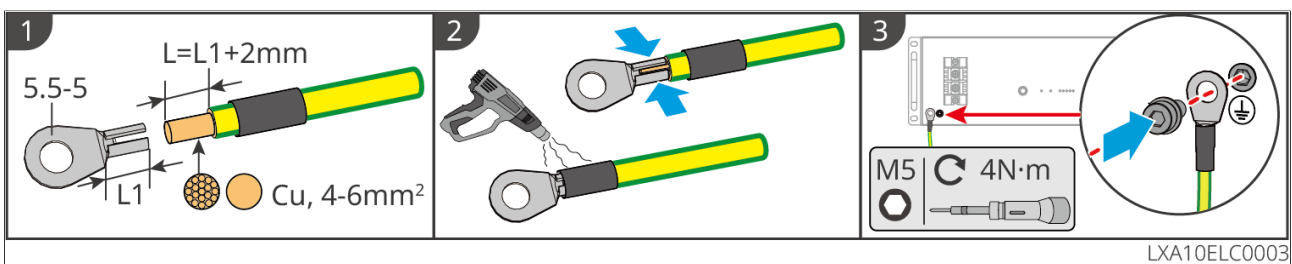
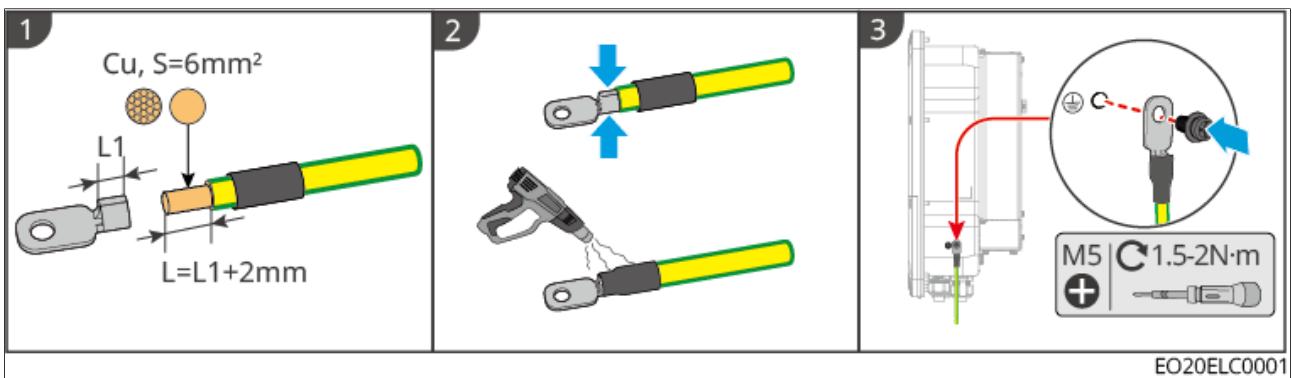

Figure14 Tightening and removing the cable gland

## 5.5 Connecting the PE cable

**!WARNING**

- The protective grounding of the chassis cannot replace the protective ground wire of the AC output port. When wiring, ensure the protective ground wires at both locations are reliably connected.
- For multiple devices, ensure all protective grounding points on the device chassis are equipotentially connected.
- To improve the corrosion resistance of the terminals, it is recommended to apply silicone or paint to the exterior of the grounding terminals for protection after the protective ground wire installation is complete.
- When installing the device, the protective ground wire must be installed first. When removing the device, the protective ground wire must be removed last.



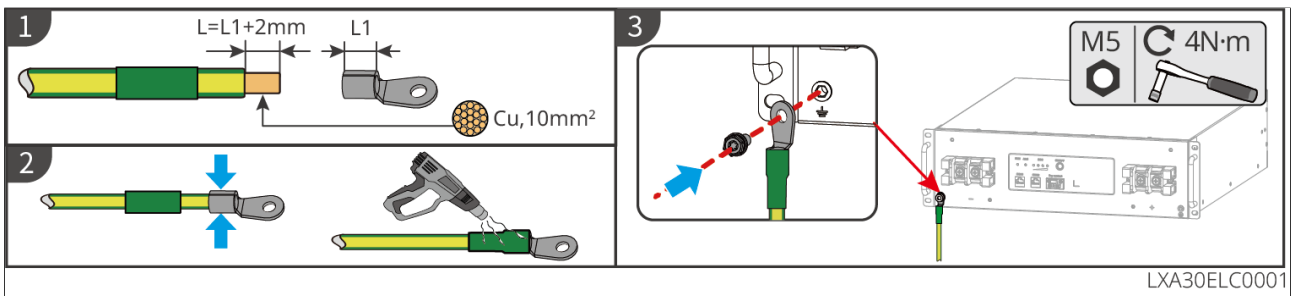

Figure17 LX A5.0-30 Battery Grounding

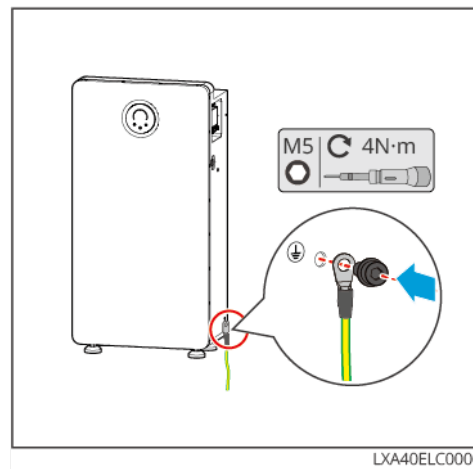

Figure18 GW16.1-BAT-LV-G10 Battery Grounding

## 5.6 Connecting the PV Cable

### DANGER

- Do not connect the same PV string to multiple inverters, as this may cause inverter damage.
- Before connecting the PV string to the inverter, confirm the following information. Failure to do so may cause permanent damage to the inverter, and in severe cases, may lead to fire causing personal injury and property loss.
  1. Ensure the maximum short-circuit current and maximum input voltage for each MPPT are within the inverter's allowable range.
  2. Ensure the positive terminal of the PV string is connected to the inverter's PV+, and the negative terminal of the PV string is connected to the inverter's PV-.

## !WARNING

- The PV string output does not support grounding. Before connecting the PV string to the inverter, ensure the minimum insulation resistance to ground of the PV string meets the minimum insulation impedance requirement ( $R = \text{Max. Input Voltage} / 30\text{mA}$ ).
- After completing the DC cable connection, ensure the cable connections are tight and secure, with no looseness.
- Use a multimeter to measure the positive and negative poles of the DC cable to ensure correct polarity (no reverse connection) and that the voltage is within the permissible range.

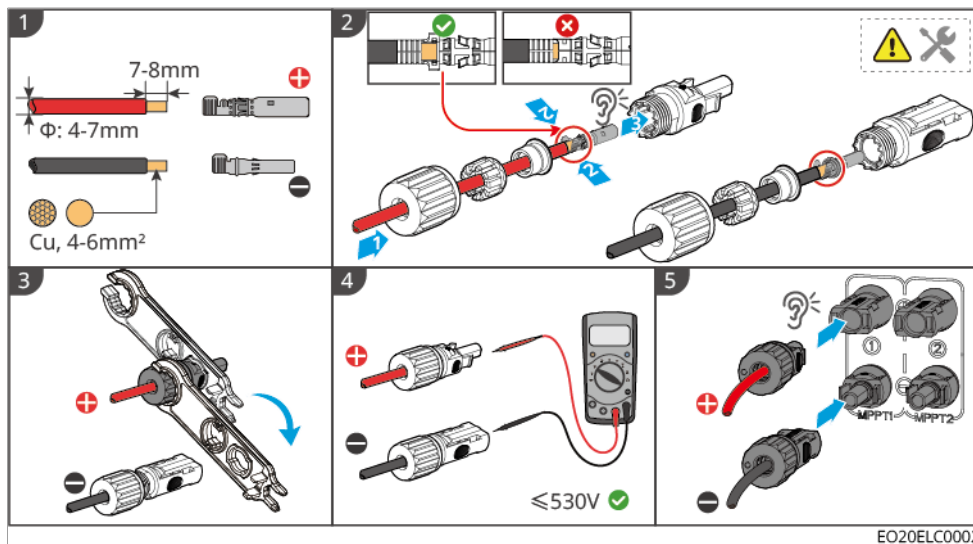

Figure19 Connecting the PV Cable

If you need to disassemble the PV terminal, please refer to the following steps:

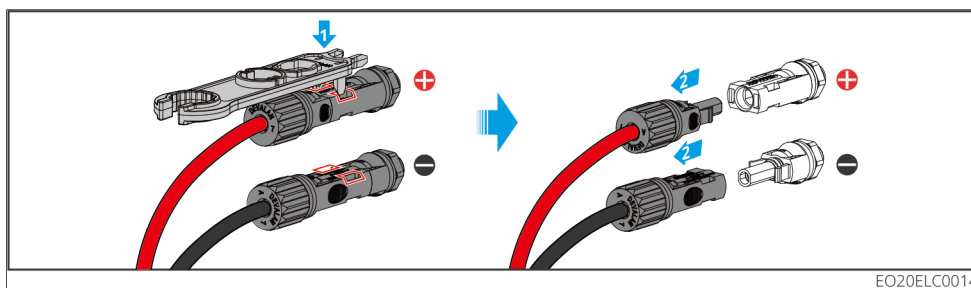

Figure20 Disassembling the PV Terminal

# 5.7 Connecting the Battery Cable



- In a single-unit system, do not connect the same battery pack to multiple inverters, as this may cause inverter damage.
- Do not connect loads between the inverter and the battery.
- When connecting battery cables, use insulated tools to prevent accidental electric shock or battery short circuit.
- Ensure the battery open-circuit voltage is within the inverter's allowable range.
- Choose whether to install a DC switch between the inverter and the battery according to local laws and regulations.

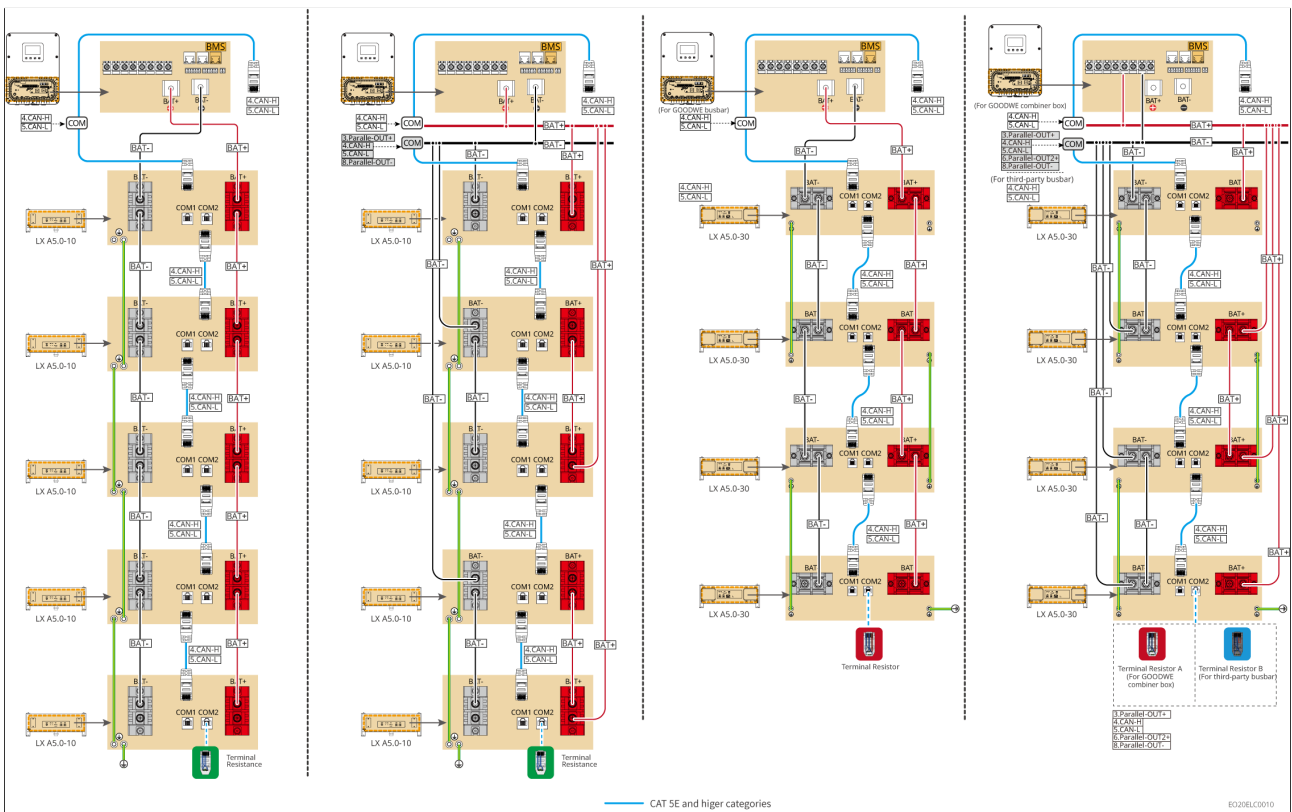

Figure 21 Battery System Wiring Diagram 1

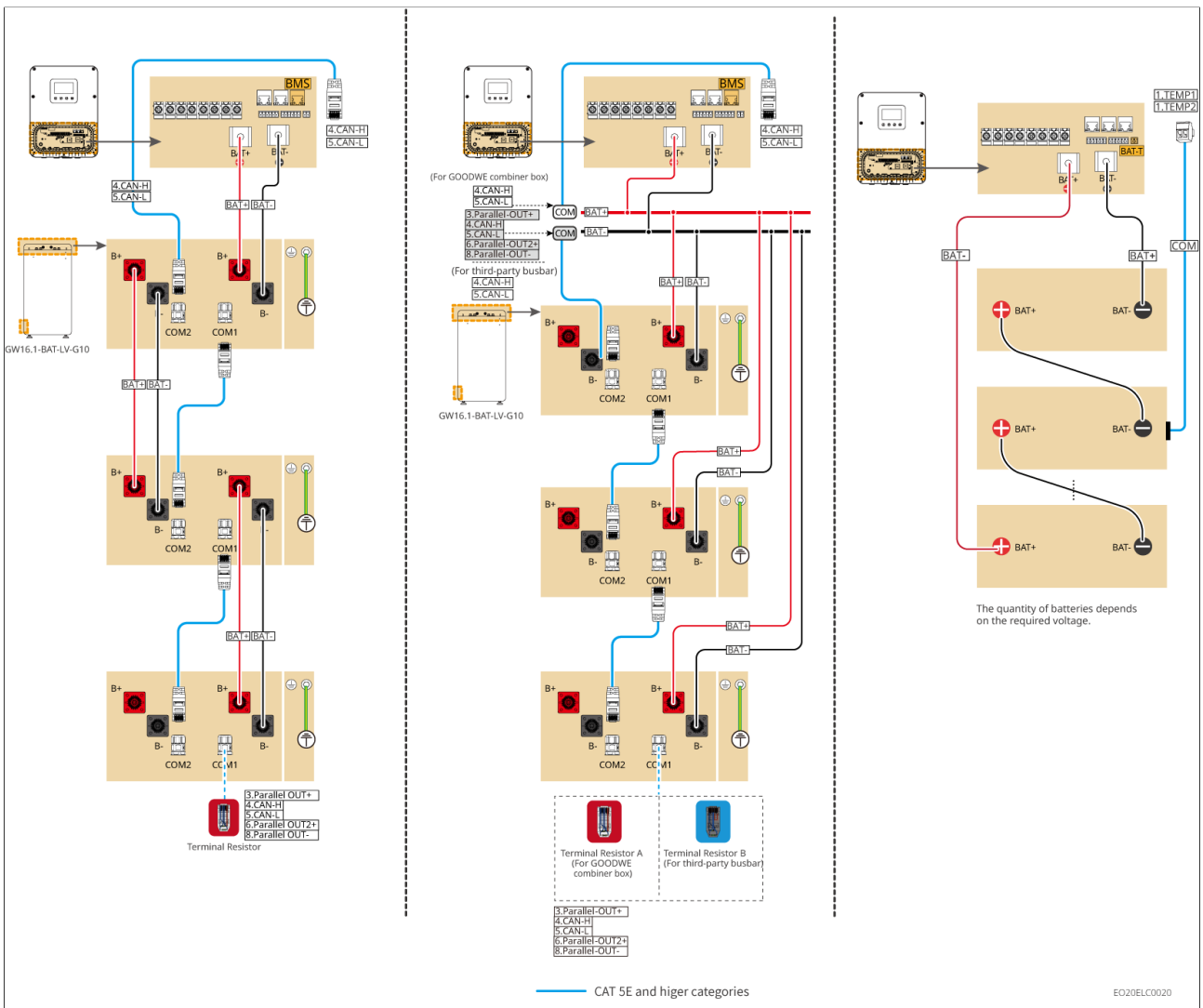

Figure22 Battery System Wiring Diagram 2

## LXA5.0-30

- Daisy-chain wiring method: Maximum connection of 1 inverter, 30 batteries

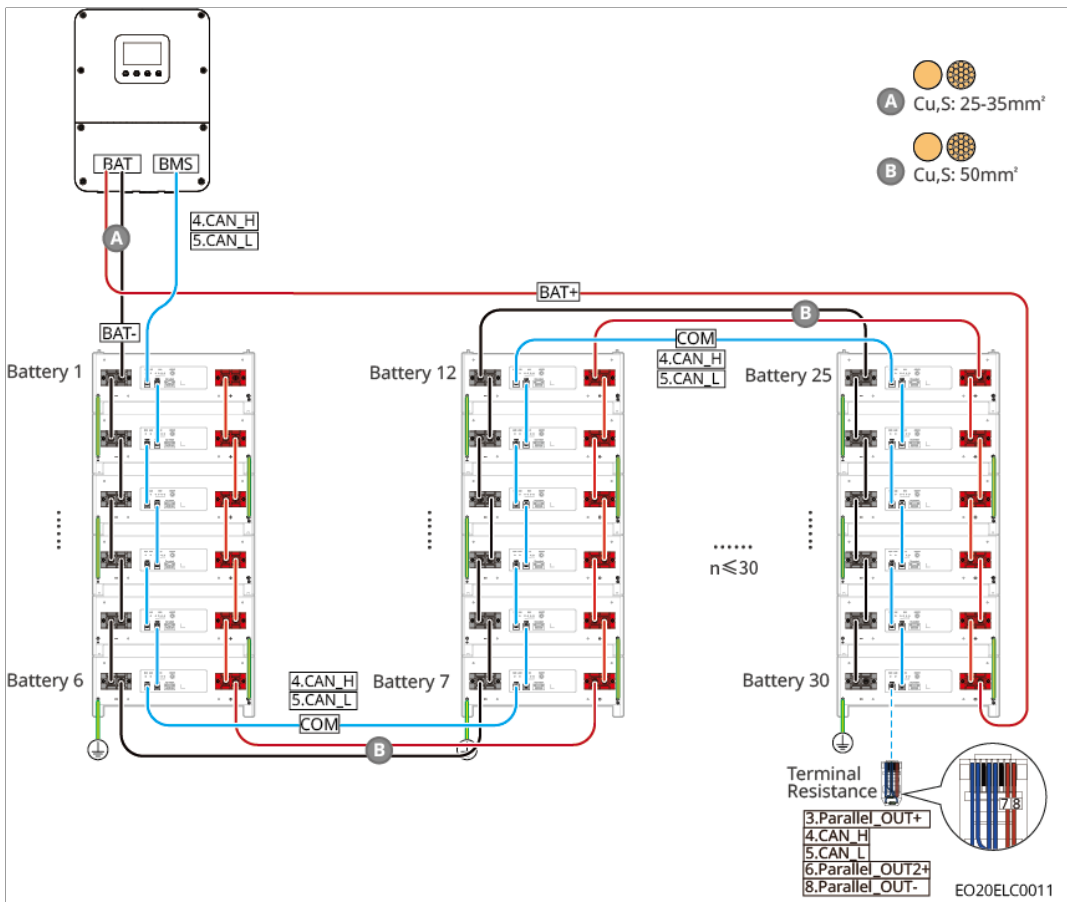

Figure23 LXA5.0-30: Daisy-chain Connection Method

- BCB-22-WW-0 combiner box wiring method: Maximum connection of 1 inverter, 6 batteries

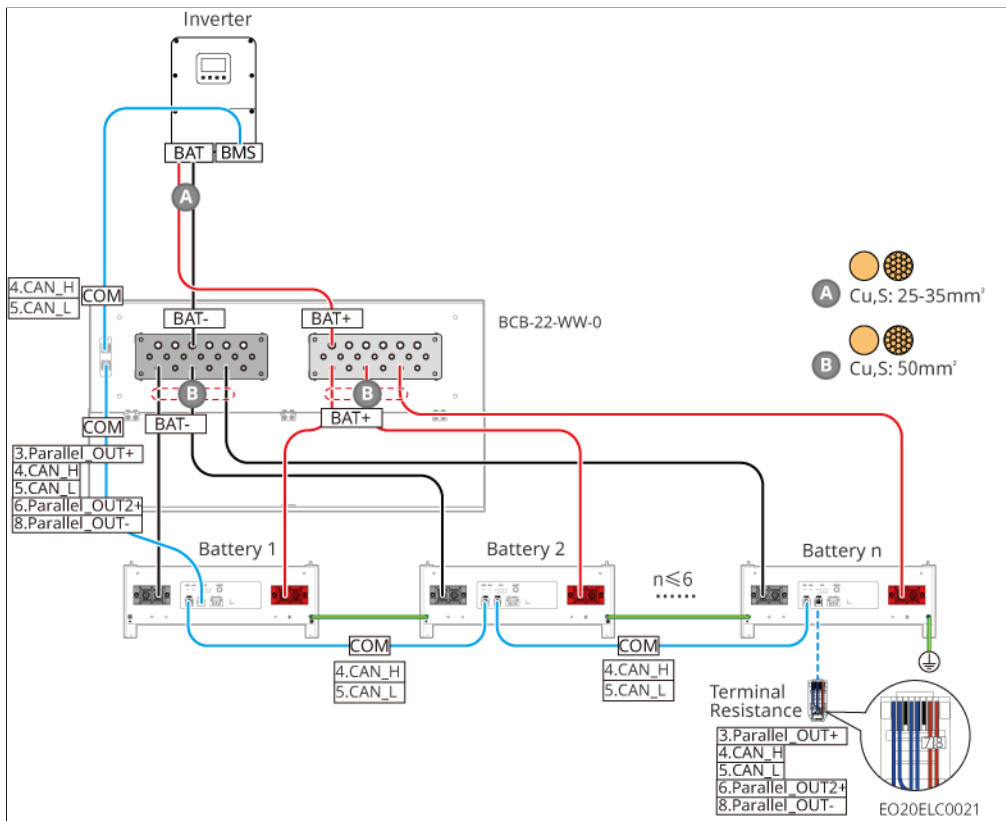

Figure24 LXA5.0-30: BCB-22-WW-0 Combiner Box

- BCB-32-WW-0 combiner box wiring method: Maximum connection of 1 inverter, 15 batteries

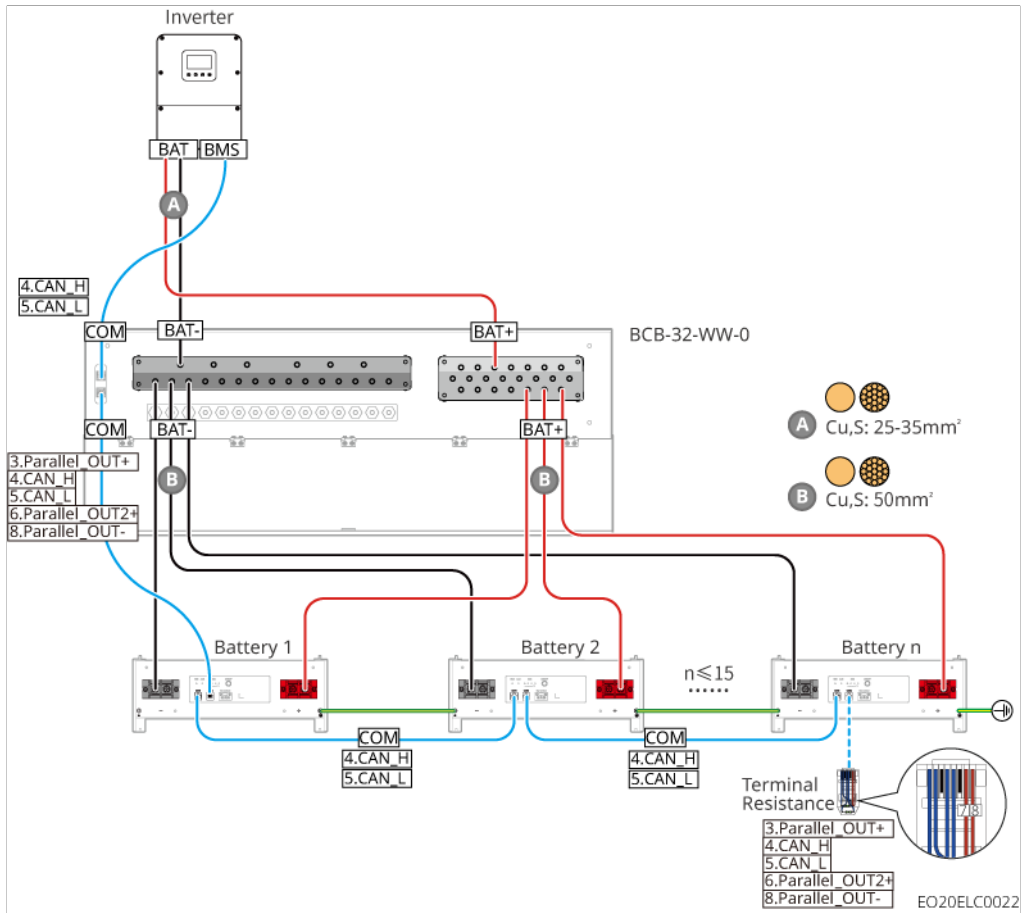

Figure25 LXA5.0-30: BCB-32-WW-0 Combiner Box

- Third-party busbar wiring method: Maximum connection of 1 inverter, 30 batteries

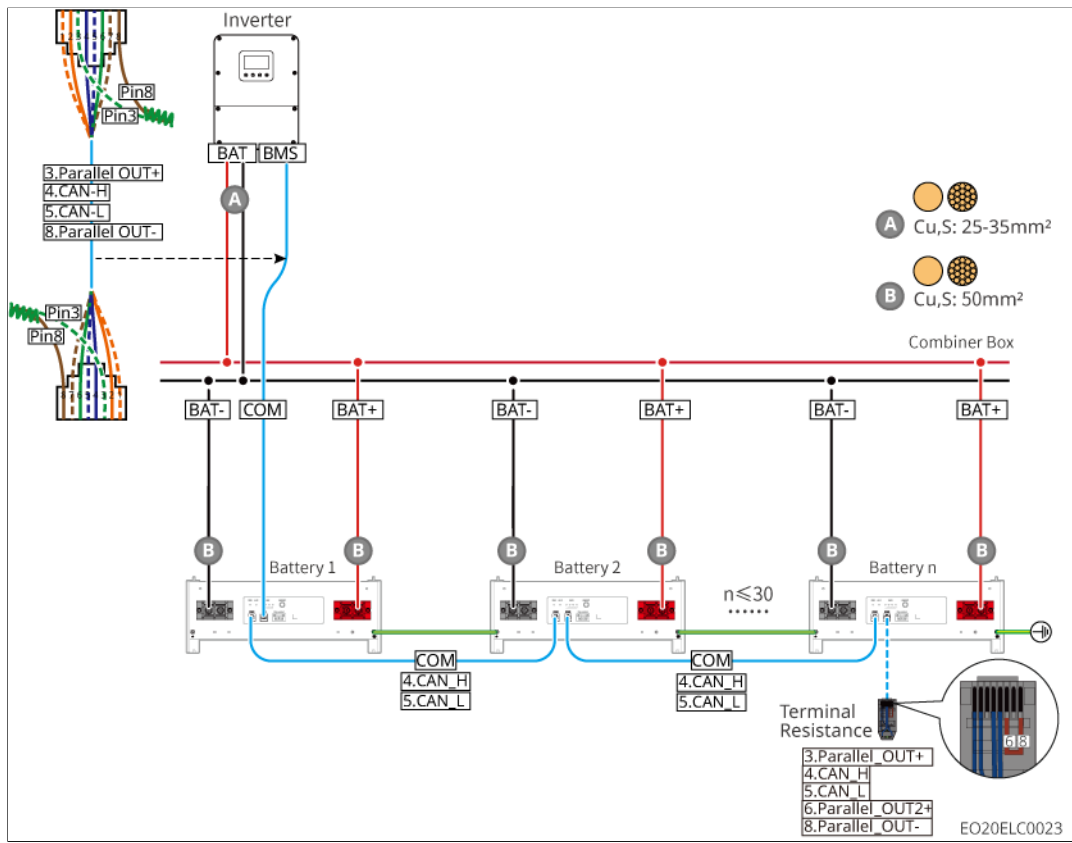

Figure26 LXA5.0-30: Third-party Busbar

## LX A5.0-10

- Daisy-chain connection method: Maximum connection of 1 inverter, 2 batteries

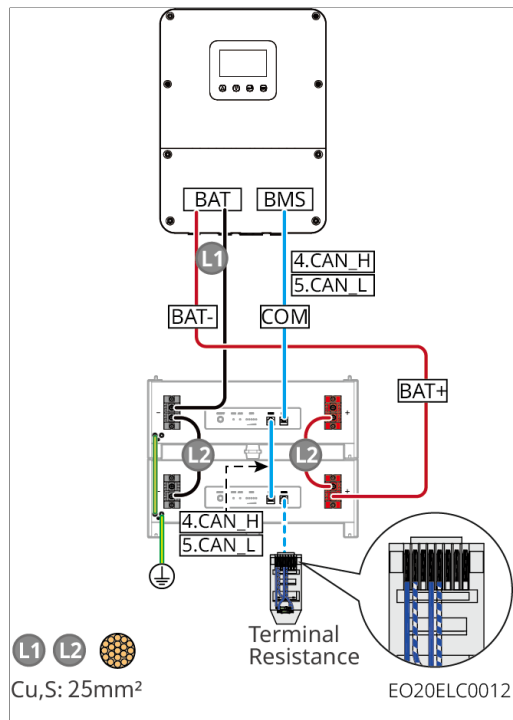

Figure27 LX A5.0-10: Daisy-chain Connection Method

- BCB-11-WW-0 combiner box wiring method: Maximum connection of 1 inverter, 6 batteries

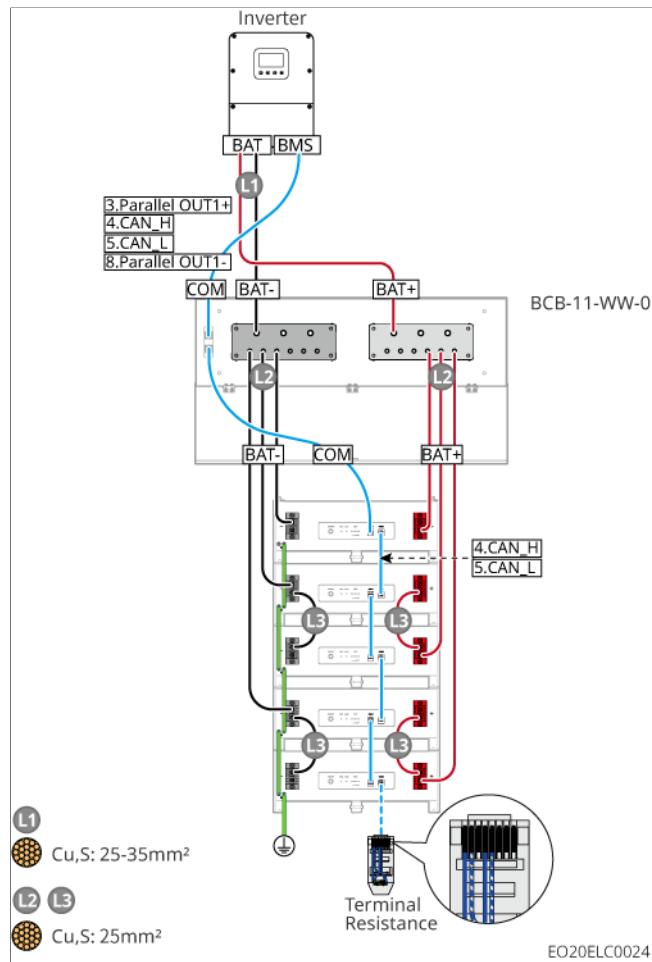

Figure28 LX A5.0-10: BCB-11-WW-0 Combiner Box

- BCB-22-WW-0 combiner box wiring method: Maximum connection of 1 inverter, 12 batteries

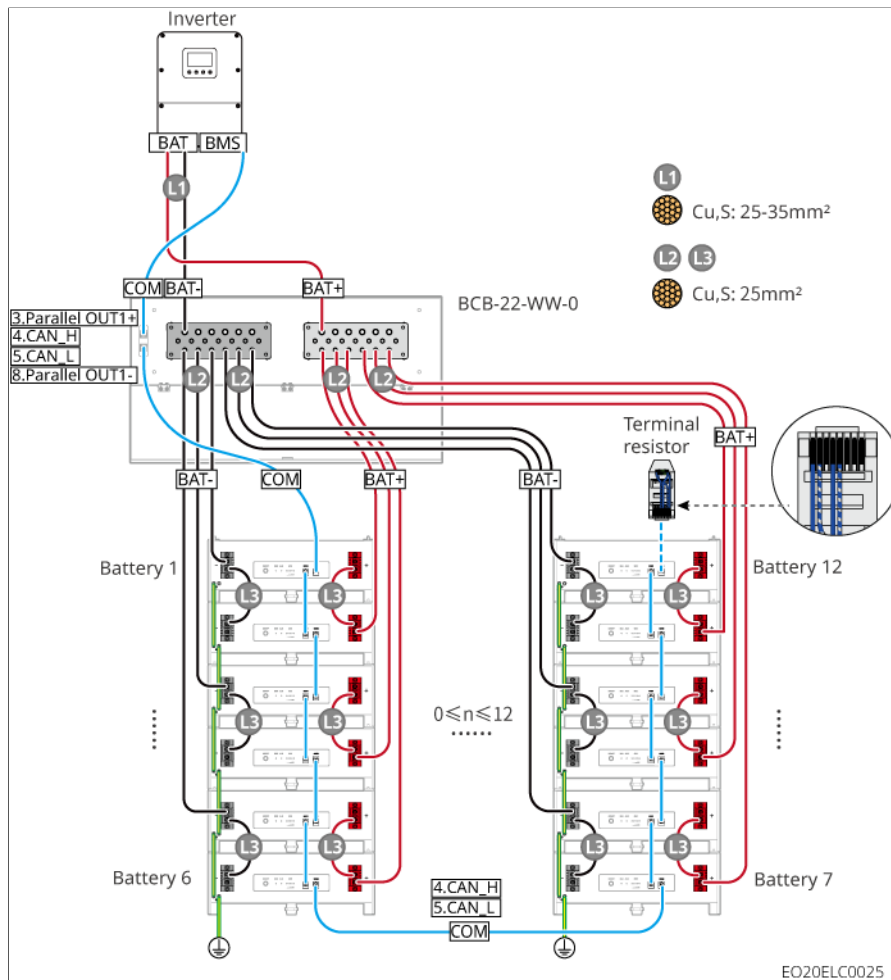

Figure29 LX A5.0-10: BCB-22-WW-0 Combiner Box

- BCB-32-WW-0 combiner box wiring method: Maximum connection of 1 inverter, 12 batteries

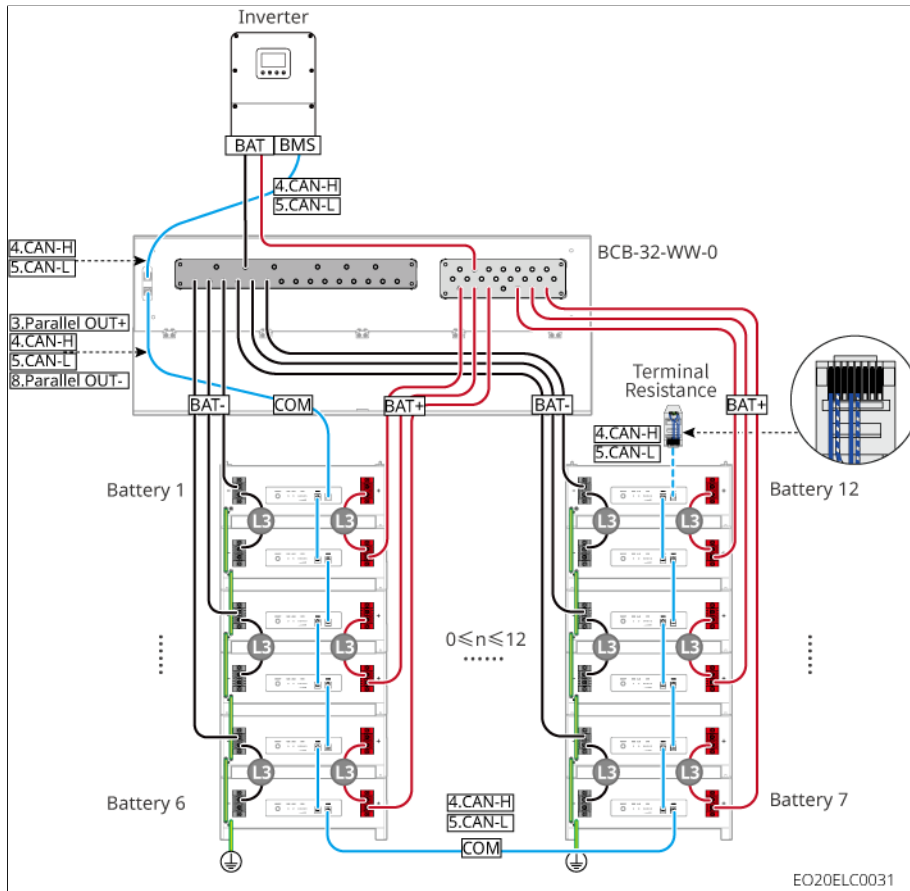

Figure30 LX A5.0-10: BCB-32-WW-0 Combiner Box

- Third-party busbar wiring method: Maximum connection of 1 inverter, 15 batteries

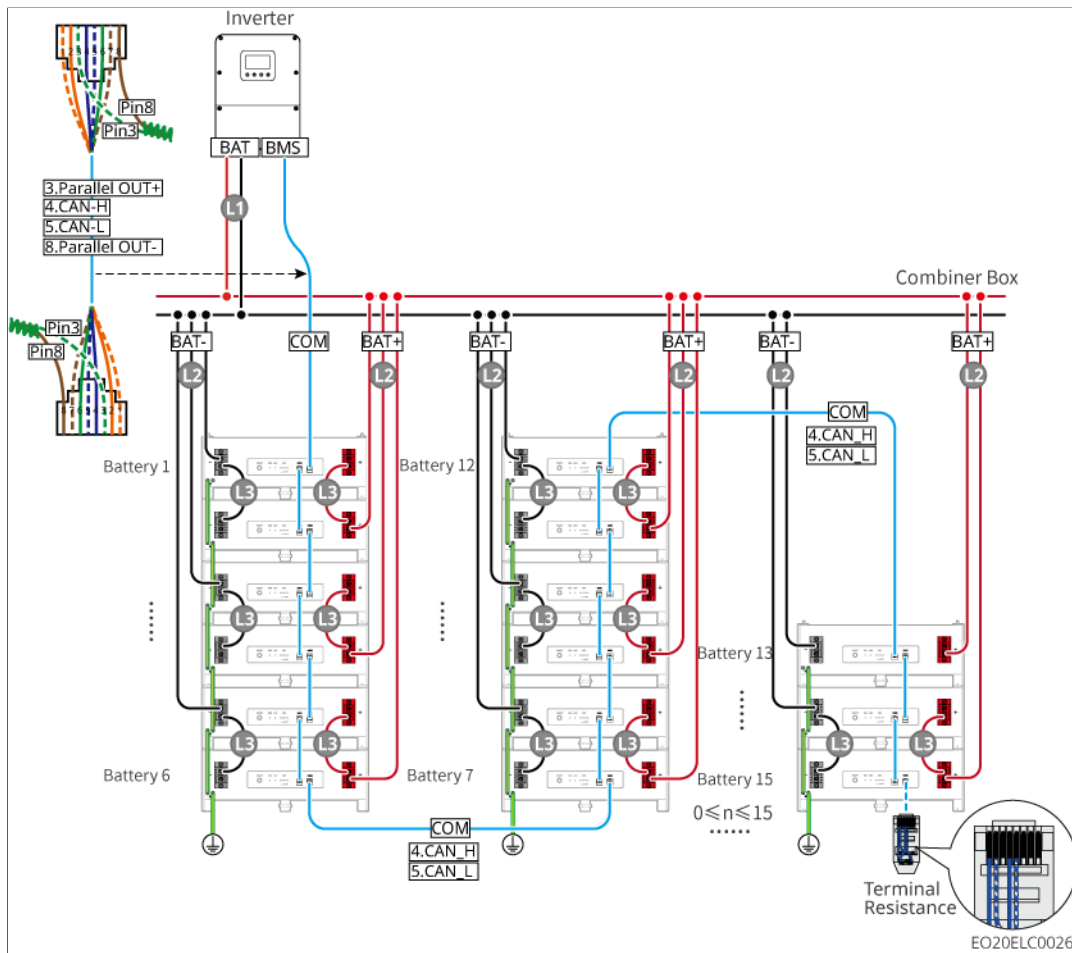

Figure31 LX A5.0-10: Third-party Busbar

### GW16.1-BAT-LV-G10

- Daisy-chain connection method: Maximum connection of 1 inverter, 30 batteries

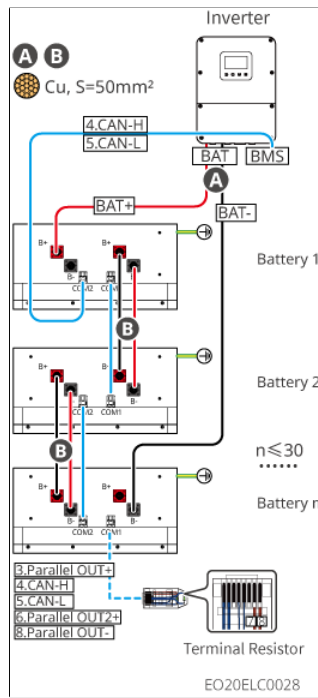

Figure32 GW16.1-BAT-LV-G10: Daisy-chain Wiring Method

- BCB-32-WW-0 combiner box wiring method: Maximum connection of 1 inverter, 15 batteries

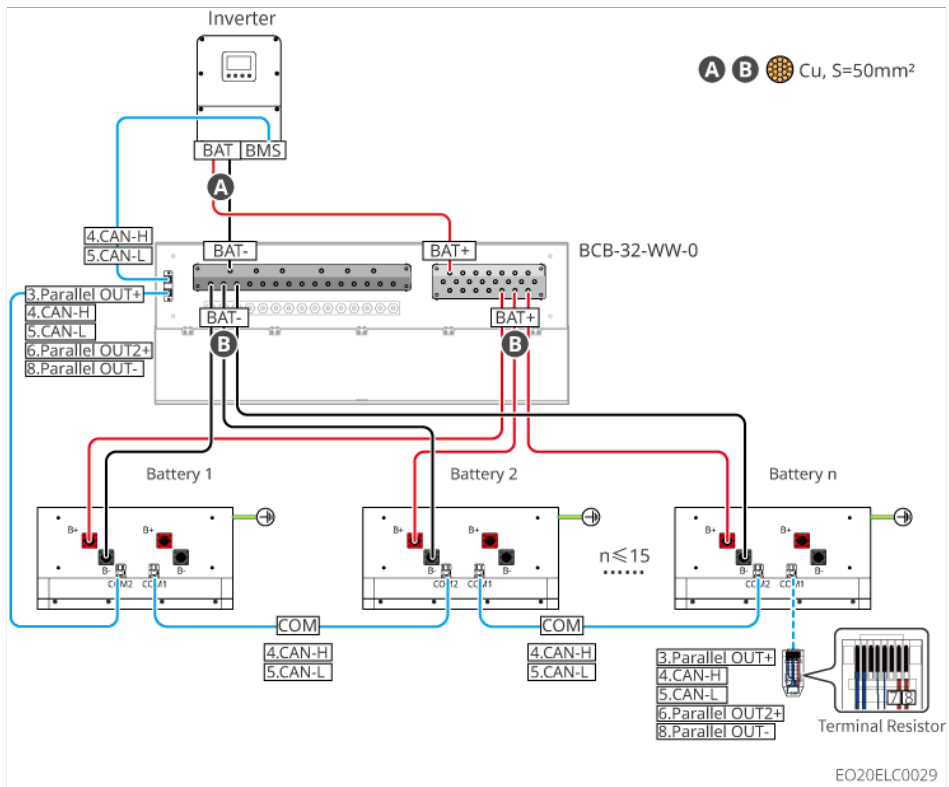

Figure33 GW16.1-BAT-LV-G10: BCB-32-WW-0 Combiner Box

- Third-party busbar wiring method: Maximum connection of 1 inverter, 30 batteries

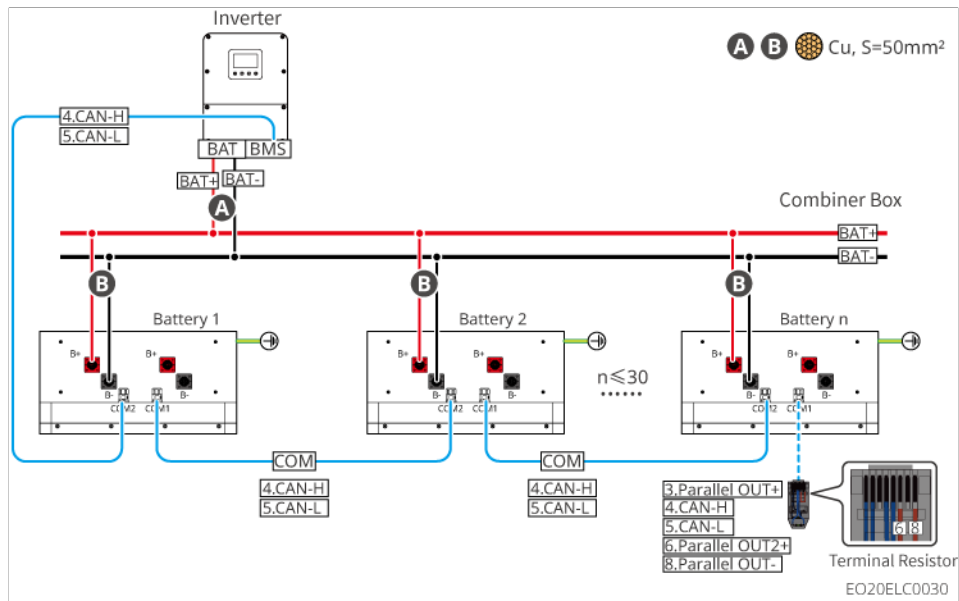

Figure34 GW16.1-BAT-LV-G10: Third-party Busbar

PIN	COM1	COM2	Description
1	-	-	Reserved
2	-	-	
3	Parallel OUT+	Parallel OUT+	Parallel communication port
4	CAN_1H	CAN_1H	Connects to inverter communication or battery cluster communication port
5	CAN_1L	CAN_1L	
6	Parallel OUT2+	Parallel OUT2+	Parallel interlock communication port
7	-	-	Reserved
8	Parallel OUT-	Parallel OUT-	Parallel communication port

Table63 LX A5.0-30 Communication Port Definition

PIN	COM1	COM2	Description
1	-	-	Reserved
2	-	-	
3	Parallel OUT+	Parallel OUT+	Parallel Communication Port
4	CAN_1H	CAN_1H	Connects to inverter communication or battery cluster communication port
5	CAN_1L	CAN_1L	
6	-	-	Reserved
7	-	-	
8	Parallel OUT-	Parallel OUT-	Parallel Communication Port

Table64 LX A5.0-10 Communication Port Definition

PIN	COM1	COM2	Description
1	RS485A	RS485A	Reserved
2	RS485B-	RS485B-	
3	Parallel OUT+	Parallel OUT+	Parallel communication port
4	CAN_H	CAN_H	Connects to inverter communication or battery cluster parallel communication port
5	CAN_L	CAN_L	
6	Parallel OUT2+	Parallel OUT2+	Parallel communication port
7	-	-	Reserved
8	Parallel OUT-	Parallel OUT-	Parallel communication port

Table65 GW16.1-BAT-LV-G10 Communication Port Definition

### 5.7.1 Connecting the Power Cable between the Inverter and Battery

#### WARNING

- Use a multimeter to measure the positive and negative poles of the DC cable to ensure correct polarity (no reverse connection) and that the voltage is within the allowable range.
- During wiring, ensure the battery cables match the "BAT+", "BAT-", and ground terminals on the battery end exactly. Incorrect cable connection will cause equipment damage.
- Ensure the wire cores are fully inserted into the terminal connection holes with no exposed parts.
- Ensure the cable connections are tight. Otherwise, loose connections may cause terminal overheating during operation, leading to equipment damage.
- Do not connect the same battery bank to multiple inverters, as this may cause inverter damage.

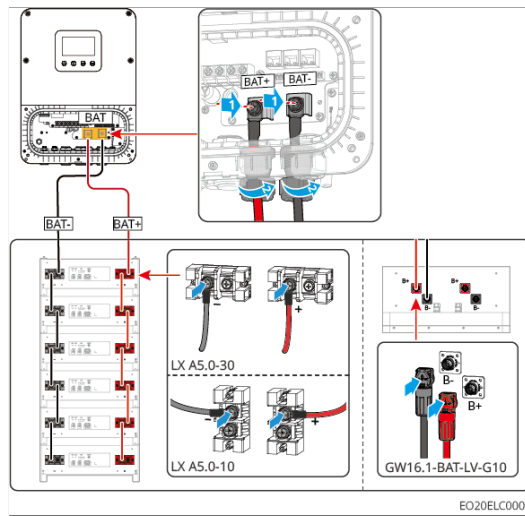

Figure35 Overview of the Inverter and Battery Power Cable

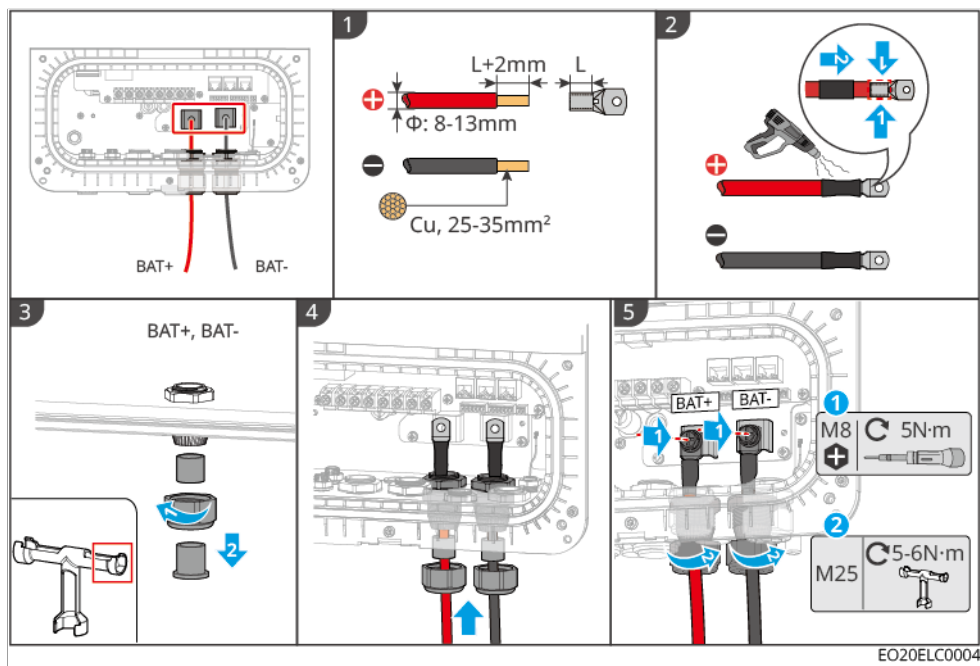

Figure36 Inverter-Side Cable Preparation

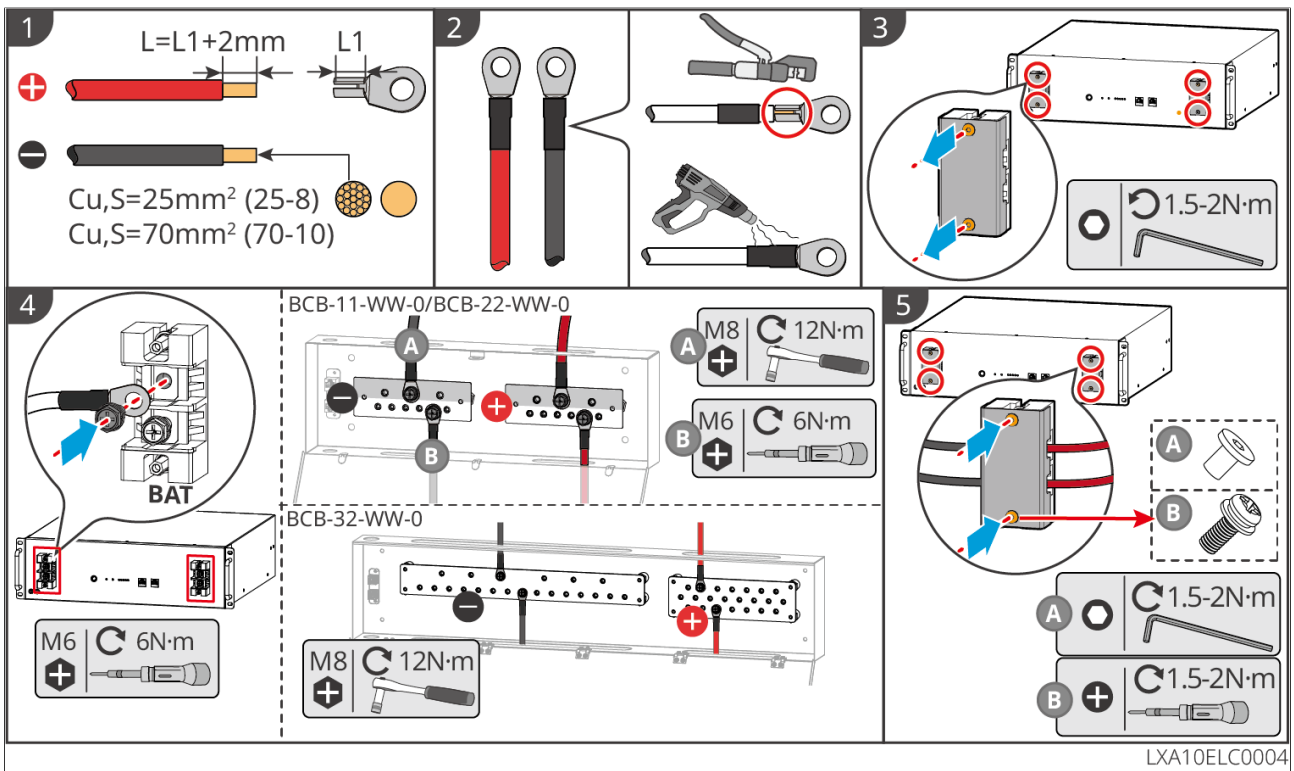

Figure37 Battery-Side Cable Preparation Method (LX A5.0-10)

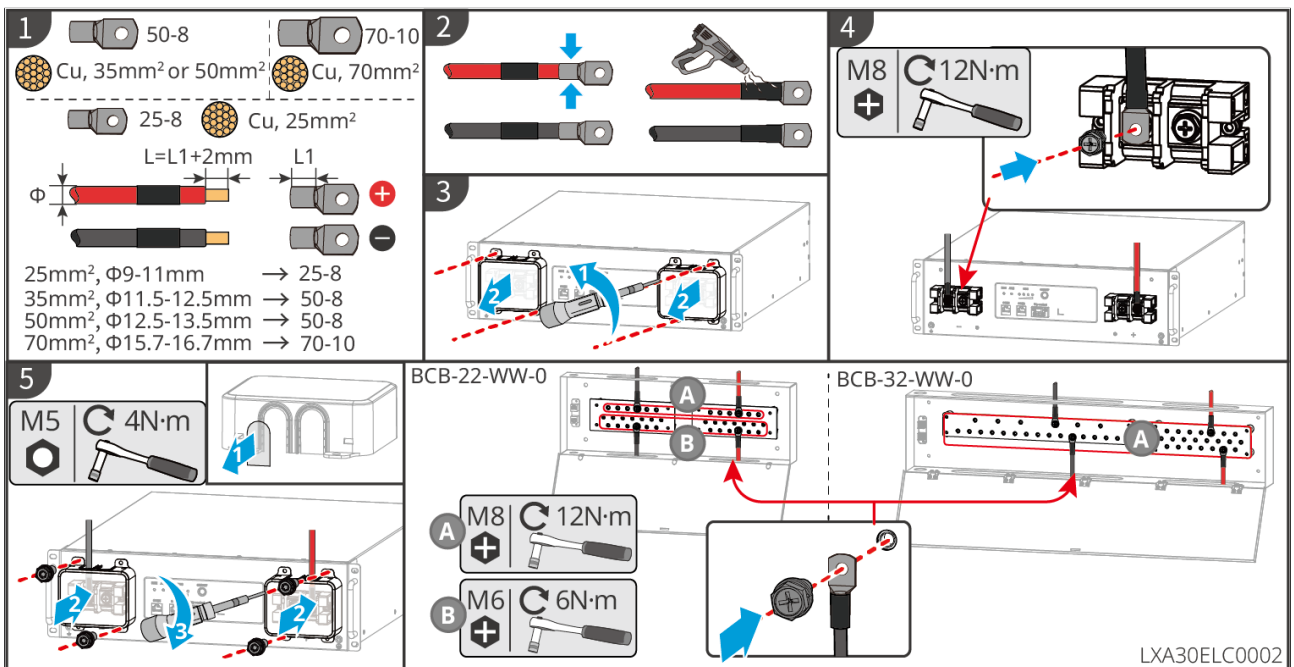

Figure38 Battery-Side Cable Preparation Method (LX A5.0-30)

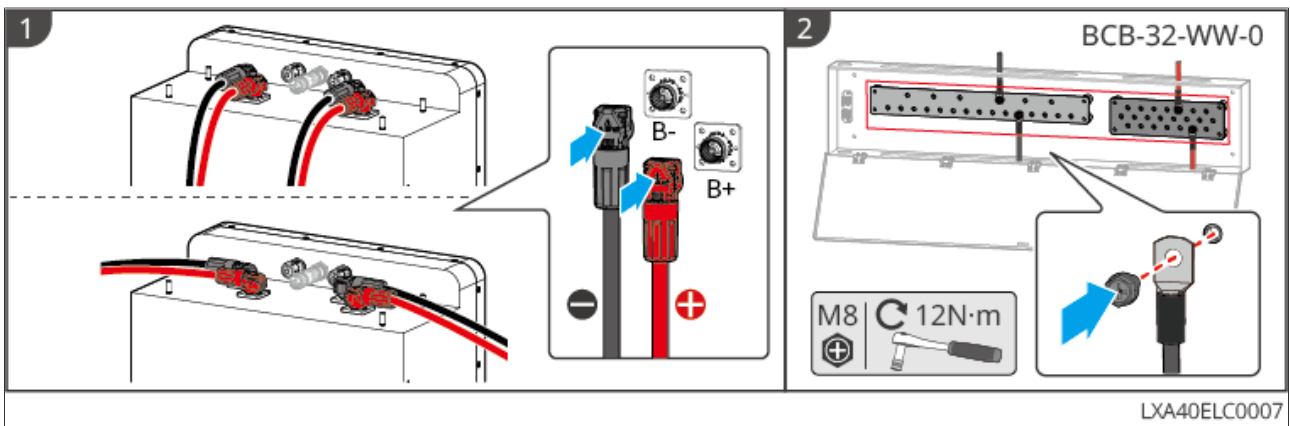

Figure39 Battery-Side Cable Preparation Method (GW16.1-BAT-LV-G10)

## 5.7.2 Connecting the Communication Cable between the Inverter and Battery

### NOTICE

The inverter comes with a BMS battery communication cable included in the package. It is recommended to use the provided BMS battery communication cable. If the included communication cable cannot meet the requirements, please prepare your own shielded network cable and shielded RJ45 connector.

Instructions for BMS Communication Connection between Inverter and Battery:

Inverter Port	Connected to Battery Port	Port Definition	Description
BMS(CAN)	COM1	4: CAN_H 5: CAN_L	<ul style="list-style-type: none"> <li>The inverter and battery communicate via CAN.</li> <li>Connect the inverter's BMS port to the battery's COM1 port.</li> </ul>

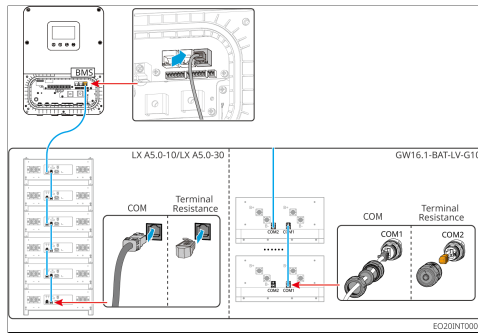

Figure40 Connecting the Communication Cable between the Inverter and Battery

## NOTICE

- When connecting the lead-acid battery temperature sensor cable, it is recommended to connect it at a less ventilated area. For example: when lead-acid batteries are placed side by side, fix the sensor on the battery located in the middle.
- To better protect the battery cells, the temperature sampling cable must be installed, and it is recommended to place the battery in a well-ventilated environment.

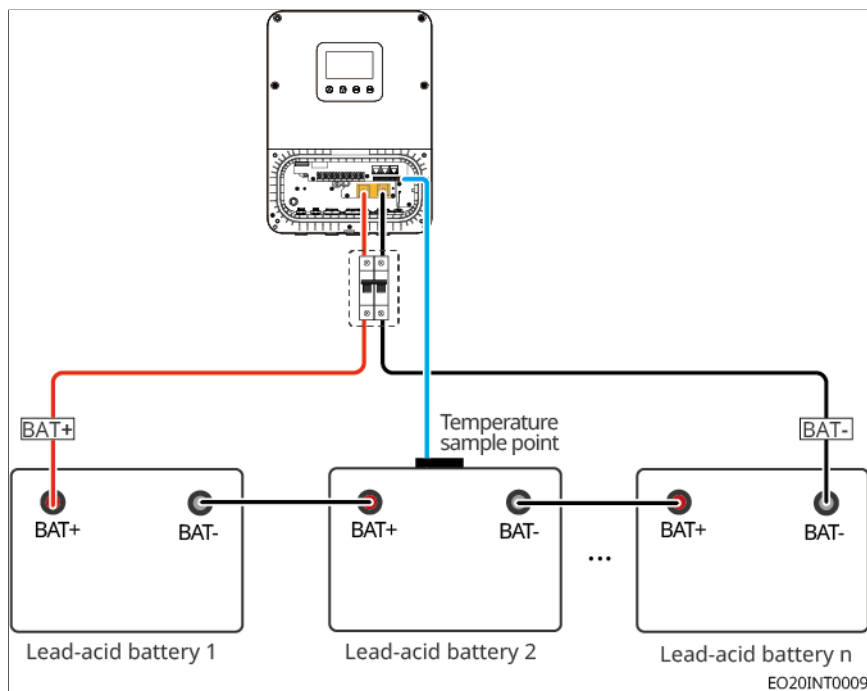

Figure41 Connecting the Temperature Sensor Cable

## 5.8 Connecting the AC Cable

### WARNING

- The inverter has an integrated Residual Current Monitoring Unit (RCMU) to prevent the residual current from exceeding the specified value. When the inverter detects a leakage current greater than the allowable value, it will quickly disconnect from the grid.
- During wiring, ensure the AC wires correctly match the "BACK-UP", "GRID", "SMART", and ground terminals on the AC terminal block. Incorrect cable connection can lead to equipment damage.
- Ensure the wire core is fully inserted into the terminal wiring hole with no exposed part.
- Ensure the insulation plate at the AC terminal is securely fastened and not loose.
- Ensure the cable connections are tight. Otherwise, during operation, overheating of the terminals may occur, causing equipment damage.

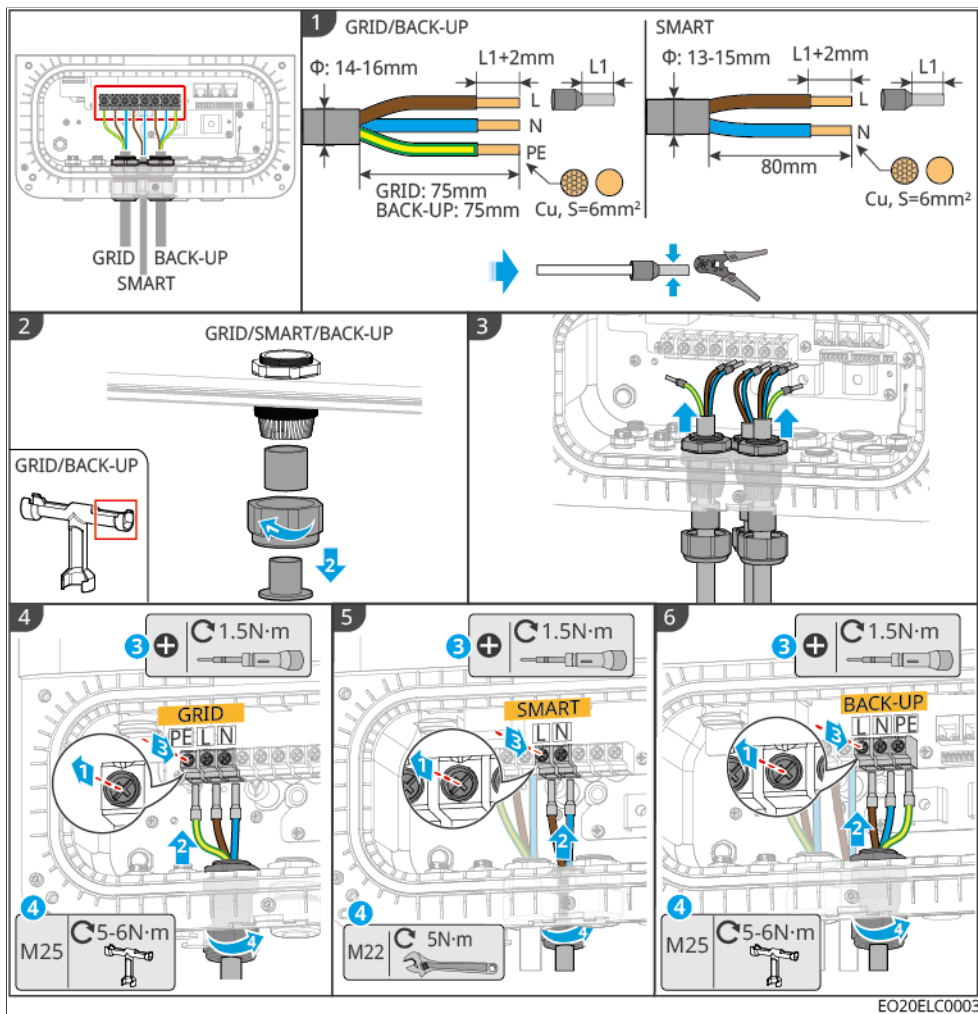

Figure42 Connecting the AC Cable

## 5.9 Connecting the Meter Cable

### NOTICE

- Ensure the CT connection direction and phase sequence are correct; otherwise, it may lead to inaccurate monitoring data.
- Ensure all cables are connected correctly, securely fastened, and free from looseness. Improper wiring may cause poor contact or damage to the meter.
- In areas with lightning risk, if the meter cable length exceeds 10m and the cable is not routed using a grounded metal conduit, it is recommended to install an external lightning protection device.

## NOTICE

- The outer diameter of the AC power line must be smaller than the CT's aperture to ensure the AC power line can pass through the CT.
- To ensure the current measurement accuracy of the CT, the recommended CT cable length should not exceed 30m.
- Do not use network cable as the CT cable, as excessive current may cause damage to the meter.
- CTs provided by different equipment manufacturers may vary slightly in size and appearance depending on the model, but the installation and wiring methods are the same.

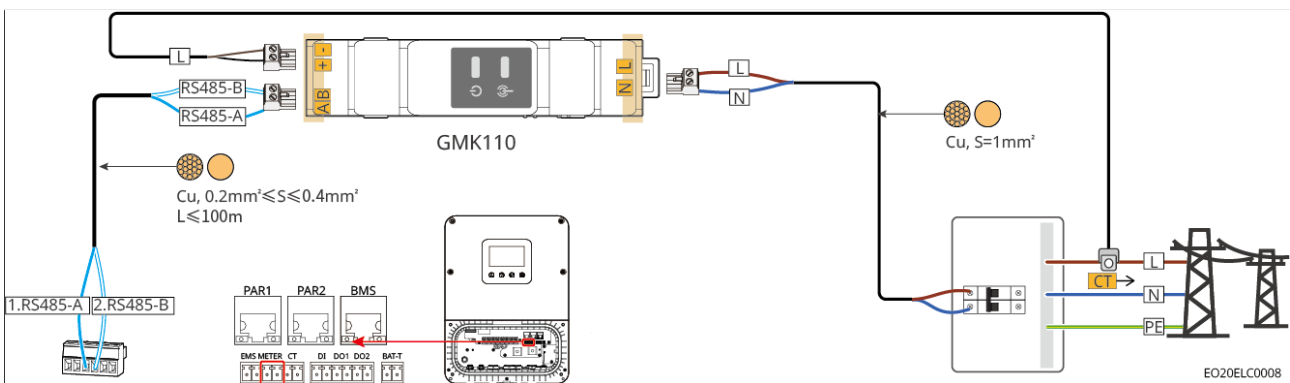

Figure43 GMK110 Meter Wiring Diagram

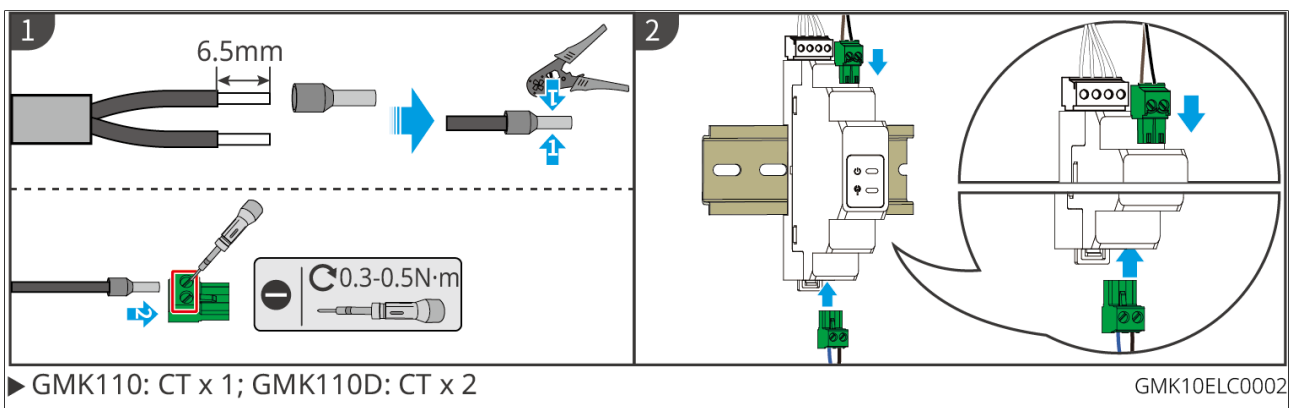

Figure44 Connecting the Meter Cable

## 5.10 Connecting the Inverter Communication Cable

### NOTICE

- The inverter communication function is optional; please select it according to your actual usage scenario.
- The inverter supports connecting to a mobile phone or WEB interface via Bluetooth or WiFi communication to set device parameters, view device operation information and error messages, and stay informed about system status in a timely manner.
- If you need to use the remote shutdown function, please enable it in the SEMS+ App after completing the wiring.
- Do not enable this function in the SEMS+ App when the inverter is not connected to a remote shutdown device; otherwise, the inverter will be unable to operate in grid-connected mode.

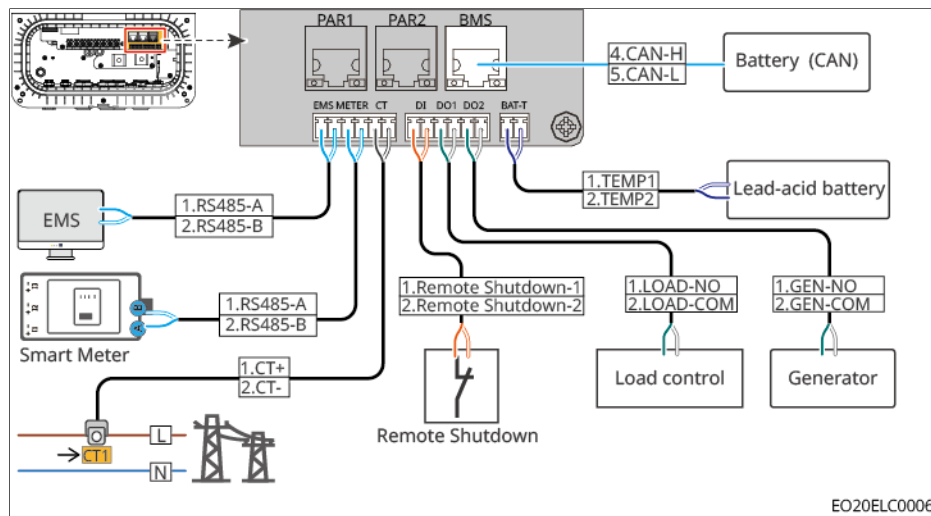

Figure45 Communication Function Description

Port (Silkscreen)	Function	Description
PAR1&PAR2	(Reserved) Parallel Communicatio n Port	-

Port (Silkscreen)	Function	Description
BMS	Battery BMS Communication	When connecting lithium-ion batteries, used to connect the battery system BMS communication cable, supports communication using CAN signals.
EMS	EMS Communication Port	When used to connect third-party EMS devices, supports RS485 communication method.
Meter	Meter Communication	Supports connecting external smart meters using RS485 communication.
CT	CT Connection Port	Connect the CT communication cable.
DI	Remote Shutdown	<ul style="list-style-type: none"> <li>• Remote Shutdown function: After the emergency switch sends a shutdown signal, the AC side of the inverter automatically disconnects, stopping grid connection.</li> <li>• Requires an external emergency shutdown switch and is controlled via the DI port: The DI port closes to start the unit; the DI port opens to stop the unit.</li> </ul>

Port (Silkscreen)	Function	Description
DO1	load control	<ul style="list-style-type: none"> <li>• Supports connection to dry contact signals to realize functions such as load control. The DO contact rating is 24Vdc @1A, NO/COM normally open contacts.</li> <li>• Supports SG Ready heat pump connection, controlling the heat pump via dry contact signals.</li> <li>• Supported working modes: <ul style="list-style-type: none"> <li>◦ Working mode 2 (Signal: 0:0 ): Energy-saving Mode. In this mode, the heat pump operates in energy-saving mode.</li> <li>◦ Working mode 3 (Signal: 0:1 ): Startup recommendation. In this mode, while maintaining the current operation, the heat pump increases hot water reserve to store heat.</li> </ul> </li> </ul>
DO2	Generator Start/Stop Control Port	Supports connecting generator control signals. The DO contact rating is 24Vdc @1A, NO/COM normally open contacts.
BAT-T	Lead-acid Temperature Measurement Port	Used to connect the temperature sensor cable for lead-acid temperature measurement; please contact the dealer for purchase if needed.

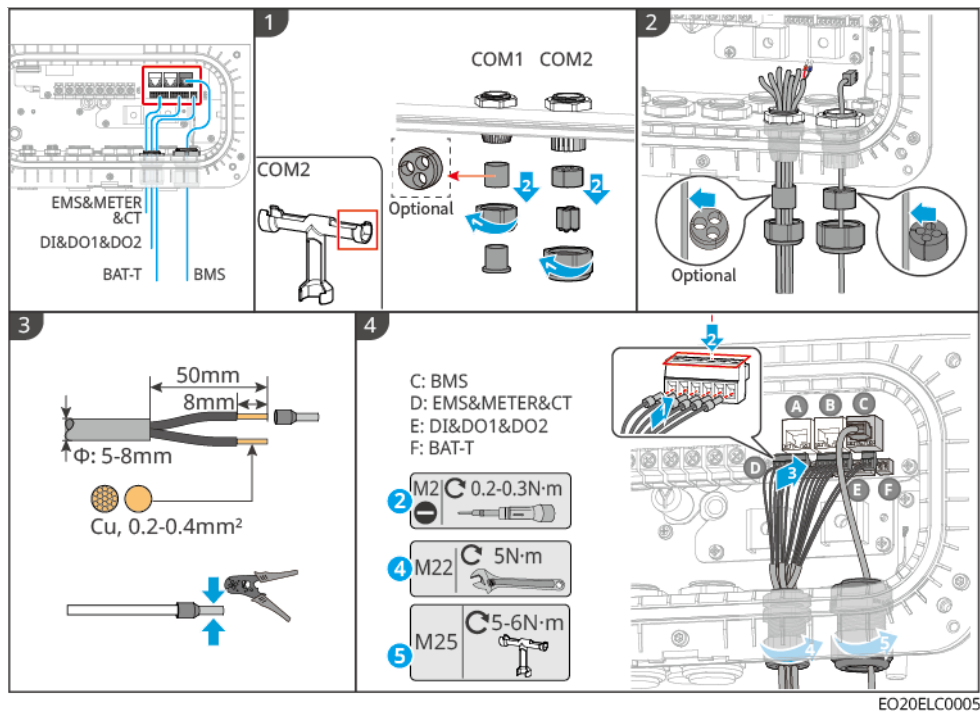

Figure46 Connecting the Communication Cable

## 5.11 Installing the Inverter Chassis Lower Cover

### NOTICE

After completing the electrical wiring, the correctness and secure fastening of the connections must be checked, and any debris left inside the wiring cavity must be thoroughly cleaned. Finally, install and securely fasten the lower enclosure cover plate to ensure waterproofing.

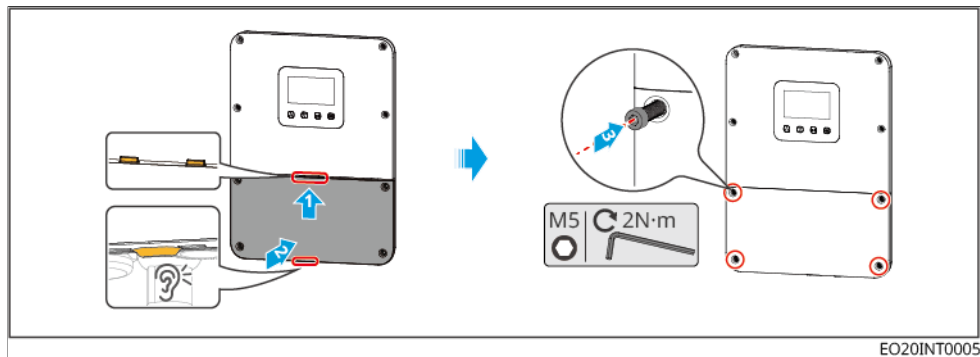
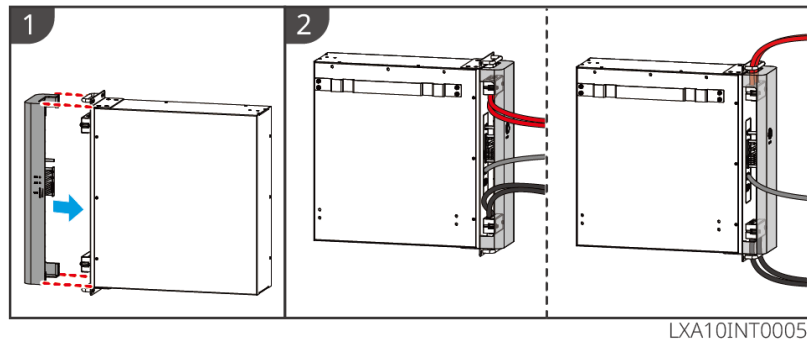

Figure47 Installing the Chassis Lower Cover

## 5.12 Install Battery Protection Cover

### 5.12.1 LX A5.0-10



### 5.12.2 LX A5.0-30

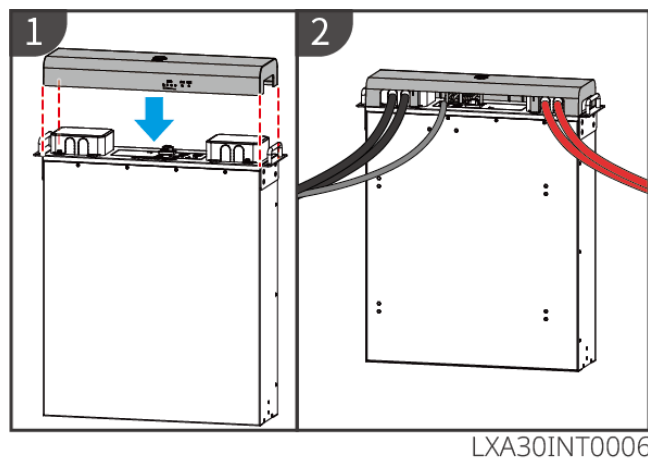

### 5.12.3 GW16.1-BAT-LV-G10

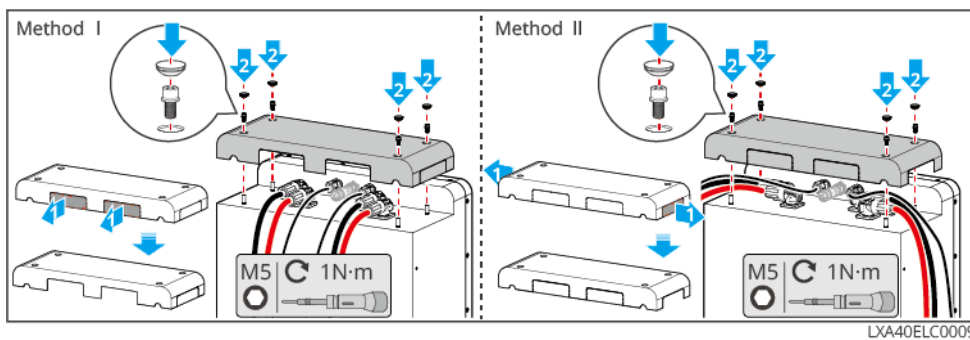

# 6 System Commissioning

## 6.1 Check Before Power ON

No.	Inspection Item
1	The equipment is installed securely, in a location convenient for operation and maintenance, with adequate space for ventilation and heat dissipation, and in a clean and tidy environment.
2	PE cables, DC cables, AC cables, Communication cables, and terminal resistors are connected correctly and securely.
3	Cables are bundled according to routing requirements, distributed reasonably, and without damage.
4	For unused cable entry holes and ports, ensure they are reliably connected using the terminals provided with the accessories and have been sealed.
5	Ensure that used cable entry holes have been sealed.
6	The voltage and frequency at the inverter grid connection point meet grid connection requirements.

## 6.2 Power ON

### WARNING

- Battery Black Start Usage Scenarios:
  - Required to activate the inverter via the battery.
  - Battery charge/discharge management is needed without an inverter.
- After the battery system starts, ensure normal communication between the inverter and the battery system within 15 minutes. If normal communication cannot be established, the battery system switch will automatically disconnect, powering off the battery system.
- When multiple battery clusters are connected in the system, starting any one battery will start all batteries.

## **Power ON Procedure**

1. Close the switch between the inverter and the battery. (Select according to local regulations.)
2. Start the battery system.
  - a. LX A5.0-10, LX A5.0-30: Briefly press the battery system switch for less than or equal to 2s.
  - b. GW16.1-BAT-LV-G10: Close the battery system integrated circuit breaker, then briefly press the battery system button.
3. Close the circuit breaker between the PV modules and the inverter.
4. Close the grid-side circuit breaker.
5. Close the BACK-UP circuit breaker.
6. Close the generator/heavy load switch.

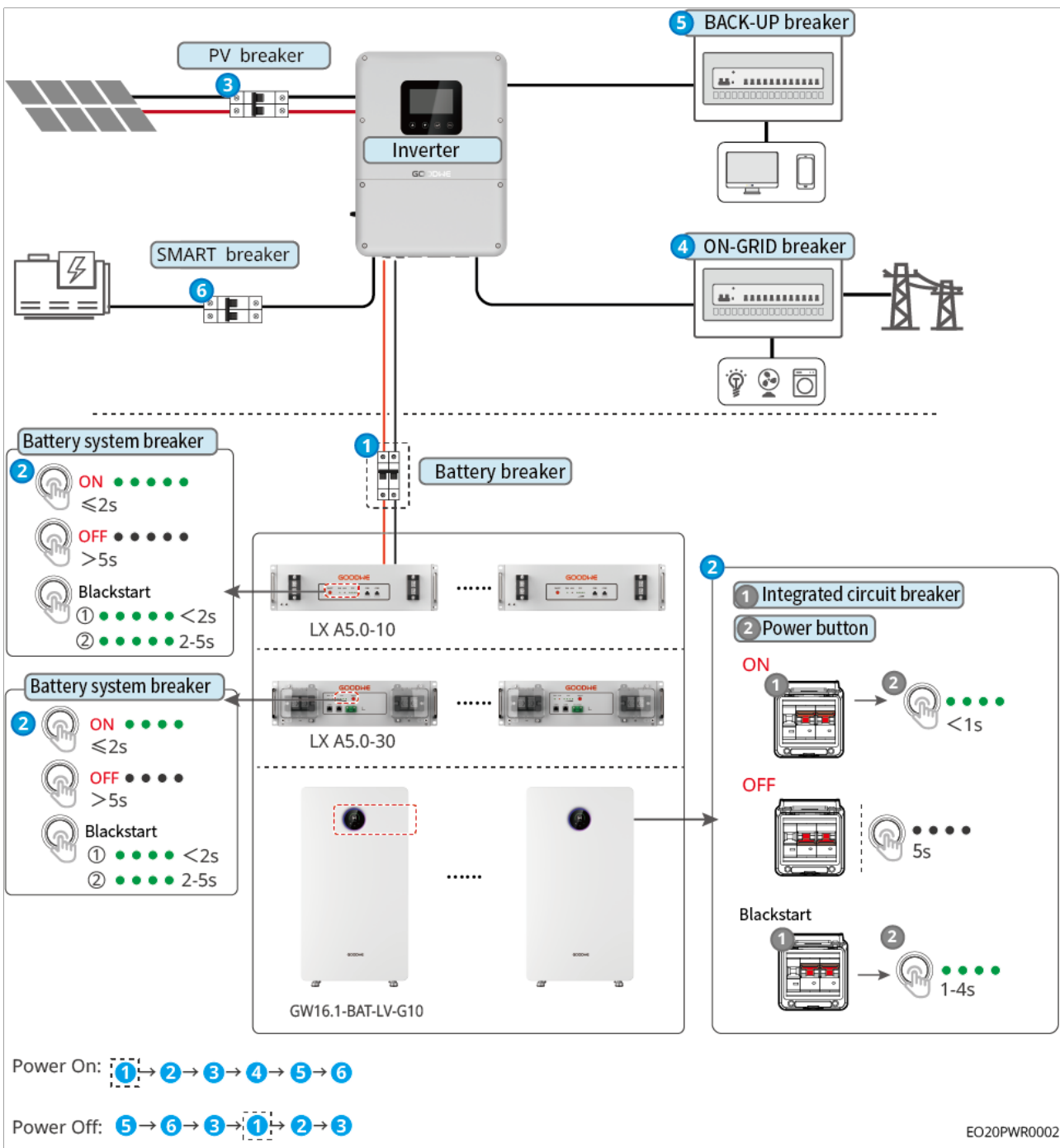

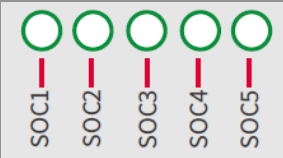







Figure48 System Power ON/OFF

## 6.3 Indicators

### 6.3.1 Battery Indicators

### 6.3.1.1 LX A5.0-10

#### Normal State







<p style="text-align: center;"><b>SOC Indicator</b></p> 	<p style="text-align: center;"><b>RUN Light</b></p> 	<p style="text-align: center;"><b>Battery System Status</b></p>
<p>The SOC indicator shows the battery system's charge level</p> <p>  SOC&lt;5%   5%≤SOC&lt;25%   25%≤SOC&lt;50%   50%≤SOC&lt;75%   75%≤SOC&lt;95%   95%≤SOC≤100%                 </p>	<p>Green blinking once per second</p> <p>Green blinking twice per second</p> <p>Green steady on</p>	<p>Battery system is in standby mode</p> <p>Battery system is idle</p> <p>Battery system is charging</p>
<p>The highest SOC indicator blinks once per second</p> <ul style="list-style-type: none"> <li>• When 5% ≤ SOC &lt; 25%, SOC1 blinks</li> <li>• When 25% ≤ SOC &lt; 50%, SOC2 blinks</li> <li>• When 50% ≤ SOC &lt; 75%, SOC3 blinks</li> <li>• When 75% ≤ SOC &lt; 95%, SOC4 blinks</li> <li>• When 95% ≤ SOC ≤ 100%, SOC5 blinks</li> </ul>	<p>Green steady on</p>	<p>Battery system is discharging</p>

#### Abnormal State

<p><b>ALM Light</b></p> 	<p><b>Battery System Status</b></p>	<p><b>Description</b></p>
<p>Red flashing once per second</p>	<p>Battery system alarm</p>	<p>After an alarm occurs, the battery system will perform a self-test. Wait for the self-test to complete; the system will then enter normal operation or a fault state.</p>

ALM Light 	Battery System Status	Description
Solid Red	Battery system fault	Determine the fault type based on the display pattern of the SOC indicator light, and handle it according to the methods recommended in the fault handling section.

### 6.3.1.2 LX A5.0-30

Indicator		System Status
	The SOC indicator shows no green light	SOC=0%
	The first SOC indicator shows green	$0% < \text{SOC} \leq 25\%$
	The second SOC indicator shows green	$25% < \text{SOC} \leq 50\%$
	The third SOC indicator shows green	$50% < \text{SOC} \leq 75\%$
	The fourth SOC indicator shows green	$75% < \text{SOC} \leq 100\%$
 RUN Light	Solid green	The battery system is operating normally
	Green blinking at 1 time/s	The battery system is in standby mode
	Green blinking at 3 times/s	PCS Comm Loss
	slow blinking	After an alarm occurs in the battery system, it will perform a self-check. Wait for the self-check to complete, then it will transition to normal operation or fault status.



Indicator		System Status
 ALM Light	Solid red	Determine the type of fault that occurred based on the display pattern of the SOC indicator, and handle it according to the methods recommended in the fault handling section.

### 6.3.1.3 GW16.1-BAT-LV-G10





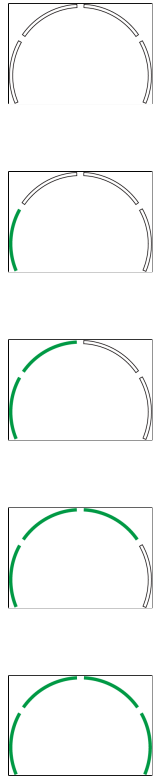

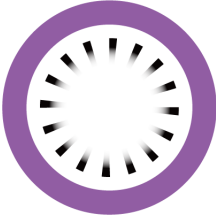
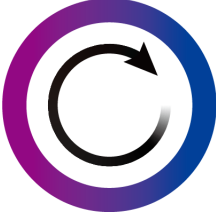

Normal State

Indicat or Name	Indicator Status		Corresponding Other Light Status	System Status
SOC Indicator		SOC indicator solid green	/	SOC=0% $0% < SOC \leq 25%$ $25% < SOC \leq 50%$ $50% < SOC \leq 75%$ $75% < SOC \leq 100%$

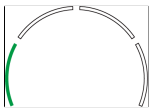
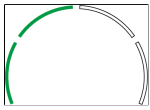

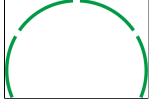
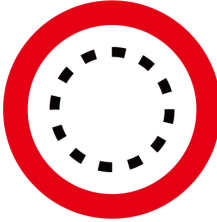
Indicator or Name	Indicator Status	Corresponding Other Light Status	System Status	
		SOC indicator blinking green	Battery system in discharge state	
Operation Indicator + Touch Button		Solid white	 Blue-purple breathing light	System operating normally
		Blinking white	 Blue-purple running light	System preparing

Indicator or Name	Indicator Status		Corresponding Other Light Status	System Status
Communication Light		Solid white	/	PCS communication normal

### Abnormal State

Indicator or Light Name	Indicator Light Status		Corresponding Other Light Status	System Status
SOC Indicator Light	   	SOC Indicator Light Green Steady On	 Red Flashing  Off  Red Steady On	Determine the fault type based on the display form of the SOC indicator light, and handle it according to the methods recommended in the fault handling chapter.
Communication Light		Off	/	PCS Comm Loss
System Alarm Light		White Steady On	/	System Alarm and Undervoltage Fault Levels 2, 3, 4

### 6.3.2 Smart Meter Indicator GMK110

Type	Status	Description
Power Indicator 	Steady On	Meter is powered on
	Off	Meter is powered off
Communication Indicator 	Flashing	Meter communication is normal
	Off	Meter communication is abnormal or not communicating

# 7 System Commissioning

## 7.1 Commissioning Method Overview

Users can configure parameters via the SEMS+ APP or through the LCD screen.

## 7.2 Configuration via LCD

### 7.2.1 LCD Overview

Via the LCD screen, users can:

1. View device operation data, software version, alarm information, etc.
2. Set parameters, safety regulation regions, etc.

### LCD Interface Overview

The LCD supports both touch and button operation.

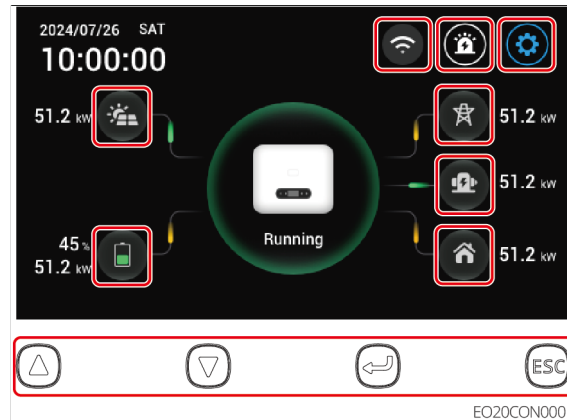
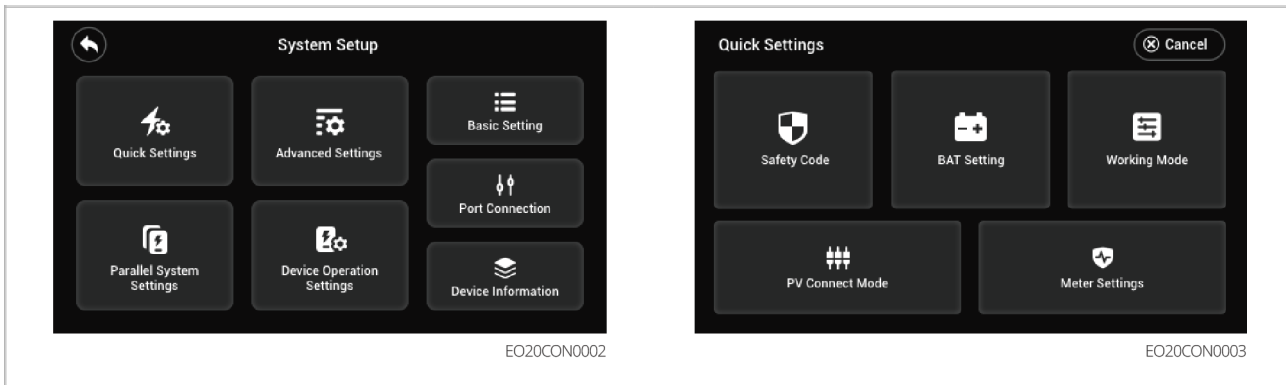

Figure49 Main Screen



Name/Icon	Description
	Up
	Down
	Confirm
	<ul style="list-style-type: none"> <li>• Short press: Exit the page</li> <li>• Press and hold  and  simultaneously for 5s: Restart the device</li> </ul>
	Used to view PV current, voltage, power generation, and other information
	Used to view battery model, status, and other information
	Used to view inverter alarms and fault information
	Press and hold for 3s to enter the inverter's setup interface
	Used to view grid status information
	Used to view generator status
	Used to view inverter load information
	Return to the main interface

Name/Icon	Description
Cancel	Return to the previous menu
Next	Go to the next setup page
Back	Return to the previous setup page

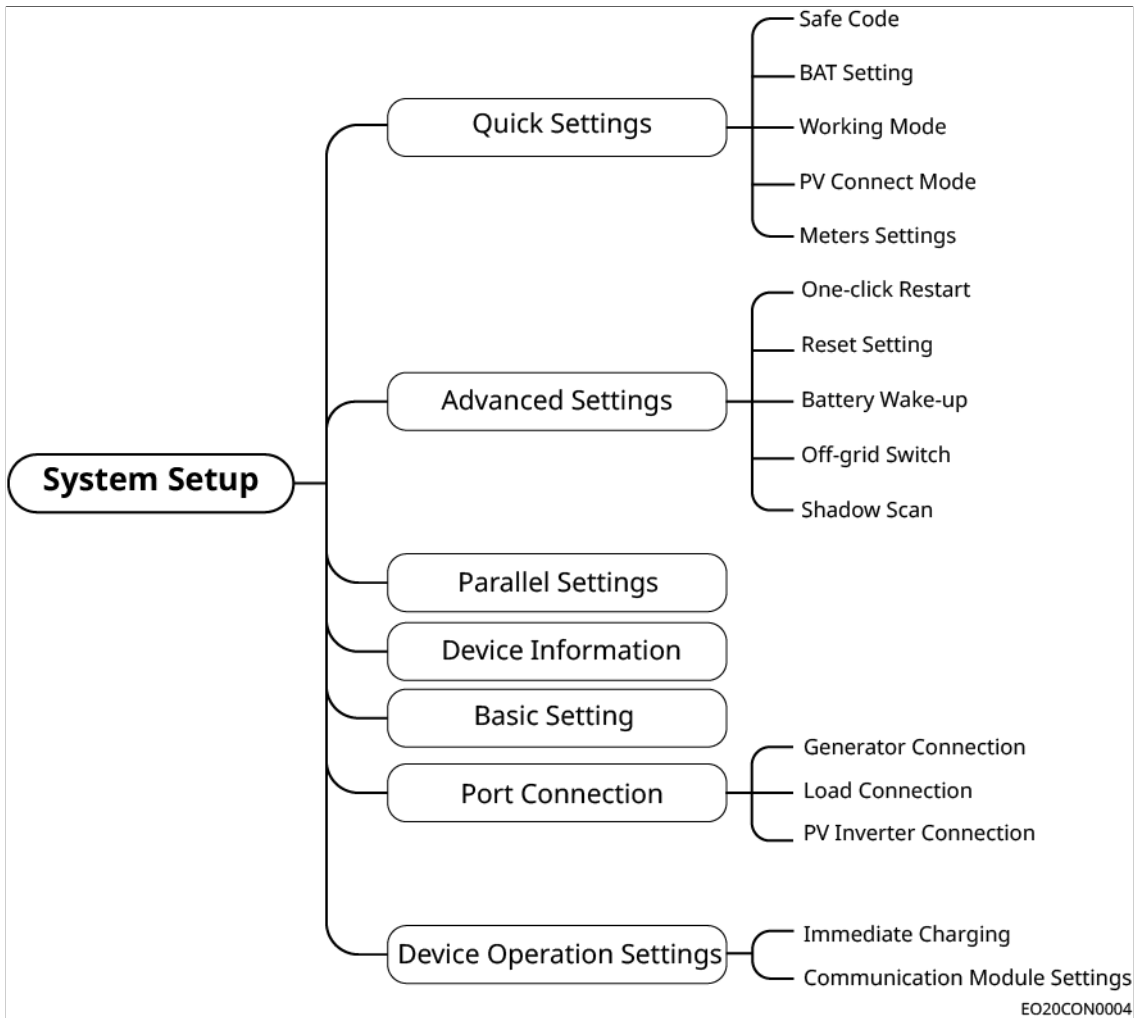



Figure50 LCD Settings Interface Structure

## 7.2.2 Quick Settings

Set Safety Regulations

1. From the main interface, click  > Quick Settings > Safe Code to enter the parameter setting interface.

2. Please select the corresponding safety regulation code based on the country or region where the device is located.
3. After completing the settings, click Confirm. The parameter setting is successful when the interface prompts Confirm OK.

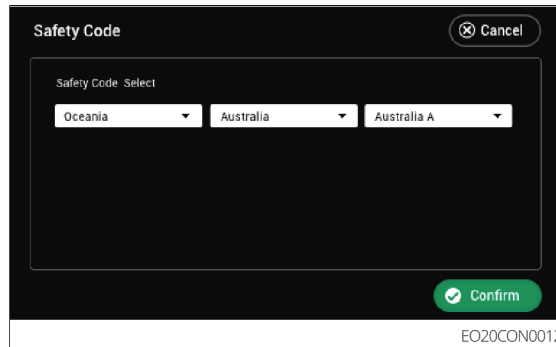



Figure51 Set Safety Regulations

### Set Battery Parameters

1. From the main interface, click  > Quick Settings > BAT Setting to enter the parameter setting interface.
2. Please set the parameters according to the actual situation.
3. After completing the settings, click Confirm. The parameter setting is successful when the interface prompts Confirm OK.

### NOTICE

Please ensure to click Confirm on each page for the parameters to take effect; otherwise, the system will run with default parameters.

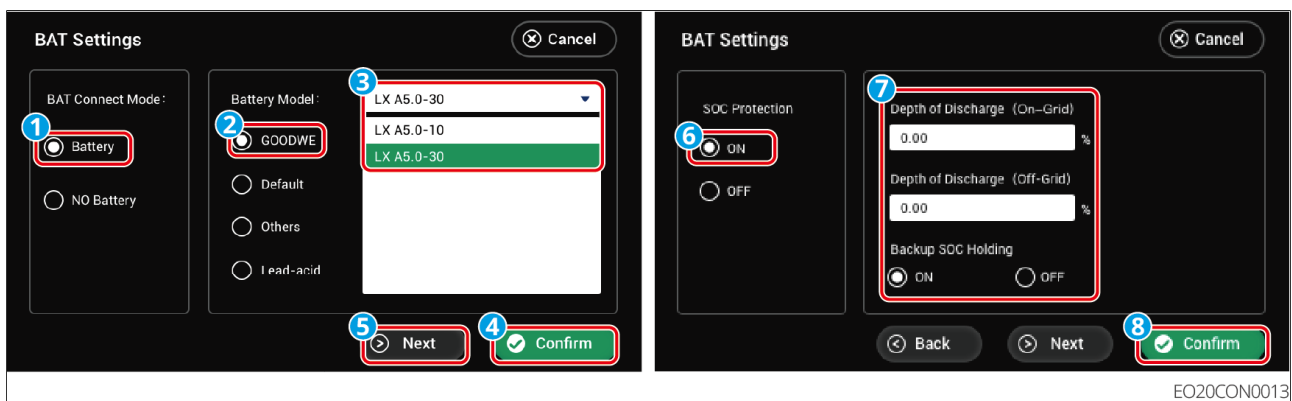

Figure52 Set Lithium Battery Parameters

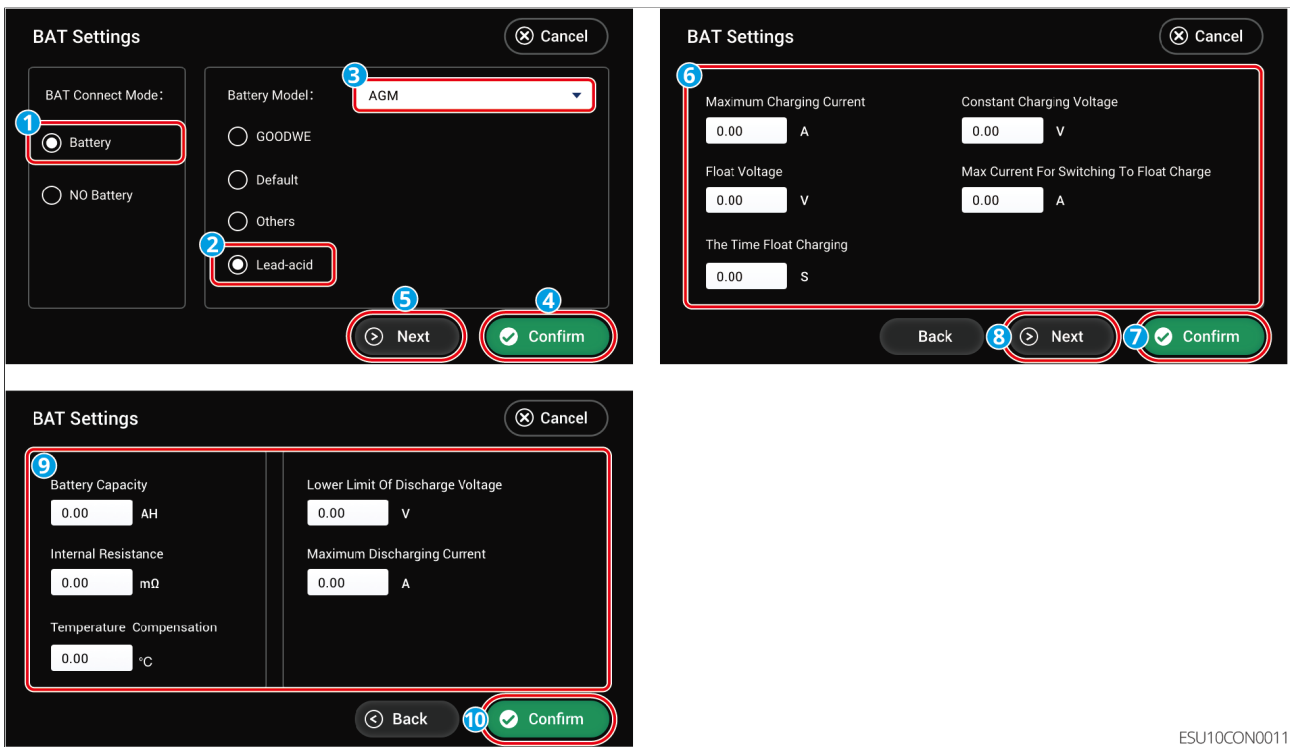

Figure53 Set Lead-Acid Battery Parameters

## Basic Parameter Settings

BAT Connection Mode	Type	Description
Battery	GOODWE	If the connected battery in the system is a GoodWe brand lithium battery, select GOODWE and choose the correct model.
	Default	If the third-party lithium battery model connected in the system is not listed here, select based on the actual situation: <ul style="list-style-type: none"> <li>Lithium 50Ah</li> <li>Lithium 100Ah</li> </ul>
	Others	If the third-party lithium battery model connected in the system is listed here, select the correct model based on the actual situation.

BAT Connection Mode	Type	Description
	Lead acid	If the connected battery in the system is a lead-acid battery, select Lead acid, and choose the correct lead-acid type. Currently supports GEL, AGM, Flooded.
NO Battery		No battery connected in the system.
BAT Setting		Configure according to the actual battery connected in the system.

### Lithium Battery Parameter Settings

Parameter Name	Description
SOC Protection	Enable or disable the SOC protection function.
Depth Of Discharge (On-Grid)	The maximum depth of discharge protection point for the battery when the inverter is operating on-grid.
Depth Of Discharge (Off-Grid)	The maximum depth of discharge protection point for the battery when the inverter is operating off-grid.
Backup SOC Holding	To ensure the battery SOC is sufficient to maintain normal system operation when off-grid, the battery will be charged to the set SOC protection value via the grid or PV when the system is operating on-grid.

### Lead-Acid Battery Parameter Settings

Parameter Name	Description
Maximum Charging Current	The battery charging defaults to constant current charging mode; It is necessary to set the maximum charging voltage and maximum charging current for this mode; please set according to the battery technical parameters.
Constant Charging Voltage	
Float Voltage	
The Time Float Charging	

Parameter Name	Description
Maximum Current For Switch To Float Charge	When the battery charging current is less than the Maximum Current For Switch To Float Charge and this condition persists for the duration of The Time Float Charging, the battery charging status switches from constant current charging mode to float charging mode. Float Voltage is the maximum battery charging voltage in float charging mode. Please set it according to the battery technical parameters.
Battery Capacity	Set the battery capacity according to the parameters of the actually connected battery.
Internal Resistance	The internal resistance present in the battery. Please set according to the battery technical parameters.
Temperature Compensation	By default, when the temperature exceeds 25°C, for every 1°C increase, the upper limit of the charging voltage decreases by 3mV. In practice, please set it according to the battery technical parameters.
Lower Limit Of Discharge Voltage	Please set according to the battery technical parameters.
Maximum Discharging Current	Please set according to the battery technical parameters. The greater the discharge current, the shorter the battery operating time.

### Set Working Mode

1. From the main interface, click  > Quick Settings > Working Mode to enter the parameter setting interface.
2. Please set the parameters according to the actual situation.
3. After completing the settings, click Confirm. The parameter setting is successful when the interface prompts Confirm OK.

### NOTICE

Please ensure to click Confirm on each page to make the parameters take effect; otherwise, the system will run with default parameters.

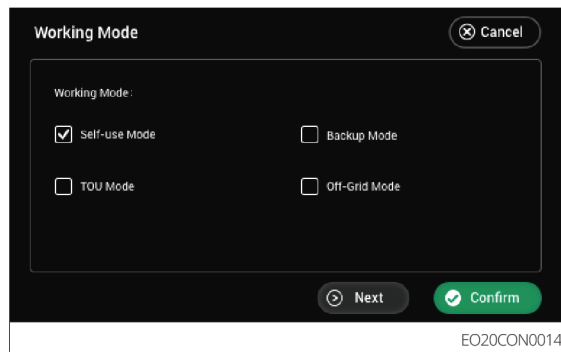



Figure54 Set Working Mode

Parameter Name		Description
Self-use Mode		When the working mode is set to Self-use Mode, the Back-up Mode, TOU Mode, and Off-Grid Mode can be enabled simultaneously. Please select according to the actual situation. The operational priority of working modes is: Off-Grid Mode > Back-up Mode > TOU Mode > Self-use Mode.
Back-up Mode	Charging From Grid	Enable this function to allow the system to purchase electricity from the grid.
	Rated Power	The percentage of power purchased from the grid relative to the inverter's rated power.
TOU Mode	Time	Within the start and end time, the battery charges or discharges according to the set charge/discharge mode and rated power.
	Charge/Discharge	Set to charge or discharge according to actual needs.
	Power (%)	The percentage of charging or discharging power relative to the inverter's rated power.
	Bat (%)	Charging stops when the battery reaches the set SOC. To set the stop SOC for battery discharge, please refer to the <a href="#">9.2.2.2 Setting Battery Parameters</a> section and set the Depth of Discharge (On-Grid) and Depth of Discharge (Off-Grid) via the LCD screen.

Parameter Name	Description
Off-Grid Mode	Do not run pure off-grid mode when the inverter is not connected to a battery system.

### Set PV Connection Mode

1. From the main interface, click  > Quick Settings > PV Connect Mode to enter the parameter setting interface.
2. Please set the parameters according to the actual situation.
3. After completing the settings, click Confirm. The parameter setting is successful when the interface prompts Confirm OK.

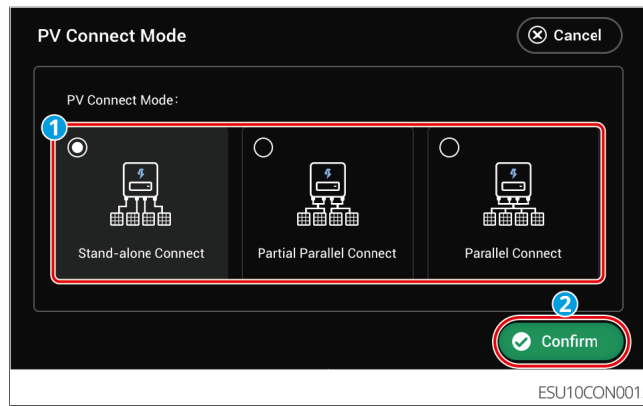



Figure55 Set PV Connection Mode

Parameter Name	Description
Stand-alone Connect	Each PV string is connected one-to-one to the MPPT port on the inverter side.
Partial Parallel Connect	When one PV string is connected to multiple MPPT ports on the inverter side, other PV strings are simultaneously connected to other MPPT ports on the inverter side.
Parallel Connect	When external PV strings are connected to the PV input ports on the inverter side, one PV string is connected to multiple PV input ports.

### Meter Settings

1. From the main interface, click  > Quick Settings > Meter Settings to enter the parameter setting interface.
2. Click Start Test to begin detection. After the detection is complete, determine the

test result based on the interface prompt.

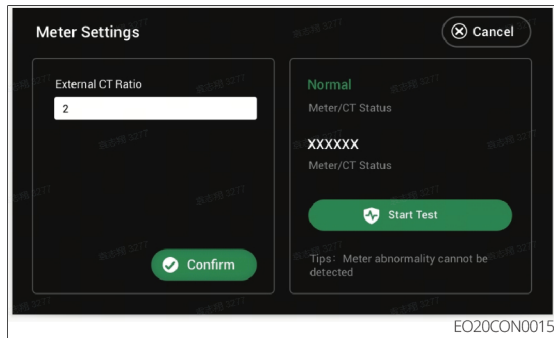

Figure56 Meter Settings

### 7.2.3 Setting Advanced Parameters

1. From the main interface, click > Advanced Settings to enter the parameter settings interface. Enter the initial password: 1111.
2. Set parameters according to actual needs.
3. After completing the settings, click Confirm. The parameters are successfully set when the interface displays Confirm OK.

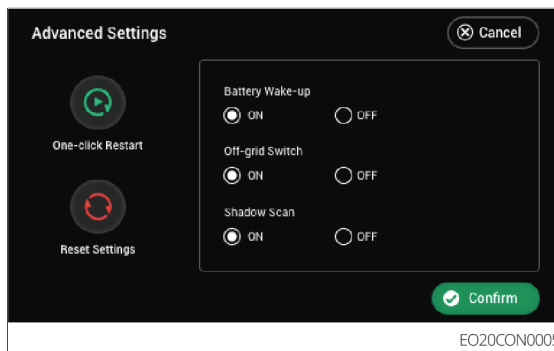



Figure57 Setting Advanced Parameters

Parameter Name	Description
One-click Restart	Using this function, you can quickly restart the inverter.
Reset Settings	The inverter restores to factory settings.

Parameter Name	Description
Battery Wake-up	When enabled, the battery can be awakened after it shuts down due to under-voltage protection. If there is a circuit breaker between the lithium battery and the inverter, ensure the circuit breaker is closed. After enabling, the output voltage at the battery port is around 60V.
Off-grid Switch	In off-grid mode, the off-grid control switch controls the enabling and disabling of the inverter's off-grid function. In grid-tied mode, this function is ineffective. The switch is initially in the ON state, enabling the off-grid function. After the inverter is powered on, it activates the off-grid output function. In off-grid state, turning the off-grid switch off and then on can clear the off-grid overload time and restart off-grid output.
Shadow Scan	When photovoltaic panels are severely shaded, enabling the shadow scan function can optimize the inverter's power generation efficiency.

## 7.2.4 Setting Immediate Charging

1. From the main interface, click  > Device Operation Settings > Immediate Charging to enter the parameter setting interface.
2. Please set the parameters according to the actual situation.
3. After completing the settings, click Confirm. The parameter setting is successful when the interface prompts Confirm OK.

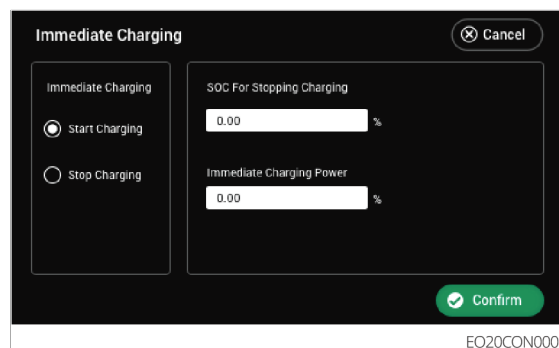



Figure58 Immediate Charging

Parameter Name	Description
Immediate Charging	When enabled, the battery is charged immediately from the grid. Takes effect only once. Please enable or stop it according to actual needs.
SOC For Stopping Charging	When Immediate Charging is enabled, battery charging will stop when the battery SOC reaches the charging cutoff SOC.
Immediate Charging Power	The percentage of the charging power relative to the inverter's rated power when Immediate Charging is enabled. For example, for an inverter with a rated power of 10kW, setting this to 60 results in a charging power of 6kW.

### 7.2.5 Setting the Basic Information

1. Through the main interface, click  > Basic Settings to enter the parameter setting interface.
2. Please set the parameters according to the actual situation.
3. After setting is completed, please click Confirm. After the interface prompts Confirm OK, the parameter setting is successful.

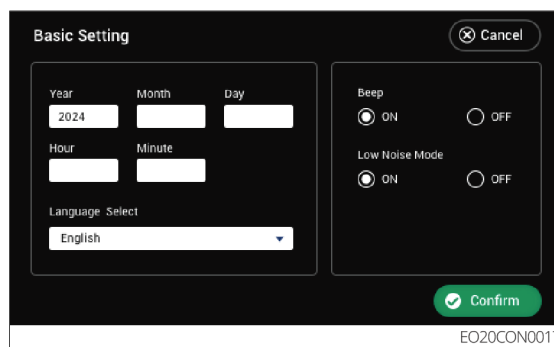



Figure59 Setting the Basic Information

Parameter Name	Description
Year/Month/Day/Hour/Minute	Set the system time.

Parameter Name	Description
Language Select	Set the screen language.
Beep	When enabled, the buzzer sounds when the inverter encounters a serious fault.
Low Noise Mode	<p>Conditions and impacts of enabling Low Noise Mode:</p> <ul style="list-style-type: none"> <li>• Prerequisite: Must be connected to a stable and reliable grid, otherwise this mode will not take effect.</li> <li>• NOTICE: If the load is too high, the system may automatically purchase power from the grid to make up the shortfall, leading to increased electricity costs.</li> <li>• Impact: During the activation of this mode, there may be some loss in photovoltaic power generation.</li> </ul>

## 7.2.6 Setting Port Connection

### Setting Port Connection for Diesel Generator

1. From the main interface, click  > Port Connection to enter the parameter setting interface.
2. Set the parameters according to the actual situation.
3. After completing the settings, click Confirm. The parameter setting is successful when the interface prompts Confirm OK.

#### NOTICE

Please ensure to click Confirm on each page to make the parameters take effect; otherwise, the system will run with default parameters.

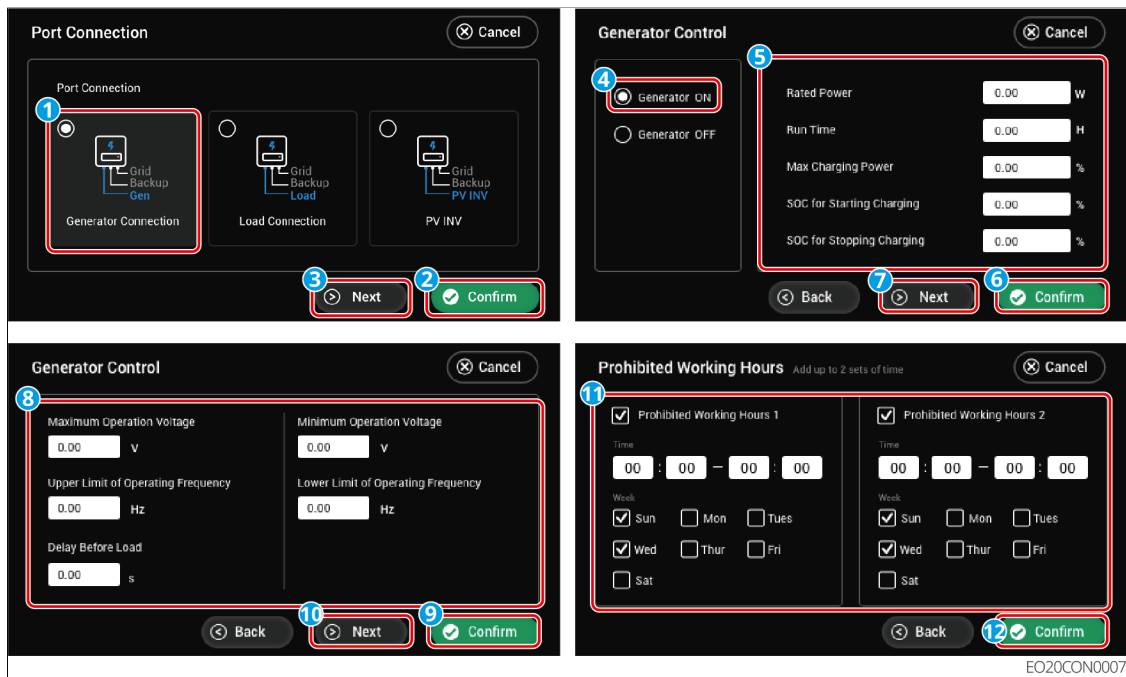



Figure60 Diesel Generator Control

No.	Parameter Name	Description
1	Generator ON/OFF	Controls the start/stop of the generator. Only applicable to generators supporting dry contact.
2	Rated Power	The rated power of the generator.
3	Run Time	The continuous operation time of the generator. The generator will automatically shut down after exceeding the set run time. This function only takes effect for generators supporting dry contact connection.
4	Max Charging Power	Sets the maximum charging power for the generator to charge the battery.
5	SOC for Starting Charging	Sets the start SOC for the generator to charge the battery. The generator will charge the battery when the battery SOC is below the set value.
6	SOC for Stopping Charging	Sets the SOC for the generator to stop charging the battery. The generator will stop charging the battery when the battery SOC reaches the set value.
7	Maximum Operation Voltage	Sets the upper limit of the generator's operating voltage.

No.	Parameter Name	Description
8	Minimum Operation Voltage	Sets the lower limit of the generator's operating voltage.
9	Upper Limit Of Operating Frequency	Sets the upper limit of the generator's operating frequency.
10	Lower Limit Of Operating Frequency	Sets the lower limit of the generator's operating frequency.
11	Delay Before Load	No-load warm-up time for the generator before applying load.
12	Prohibited Working Hours	Please set the generator's prohibited working hours according to the actual situation.

### Setting Port Connection for Load Control

1. From the main interface, click  > Port Connection to enter the parameter setting interface.
2. Set the parameters according to the actual situation.
3. After completing the settings, click Confirm. The parameter setting is successful when the interface prompts Confirm OK.

### NOTICE

Please ensure you click Confirm on each page for the parameters to take effect; otherwise, the system will run with default parameters.

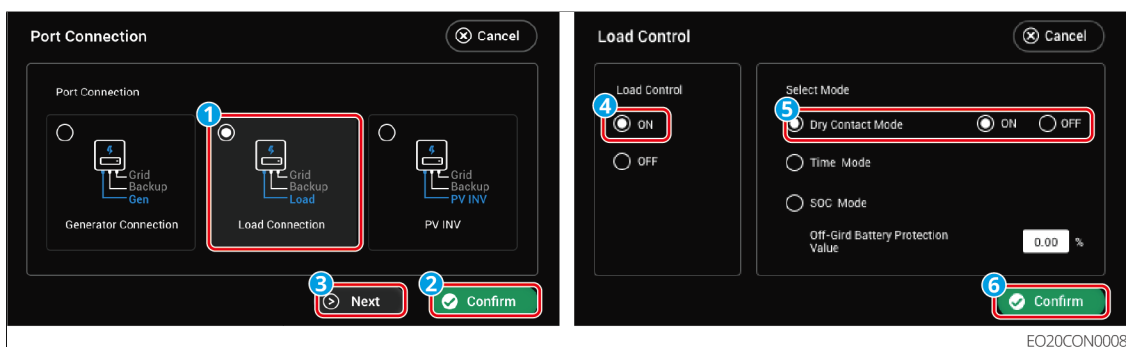
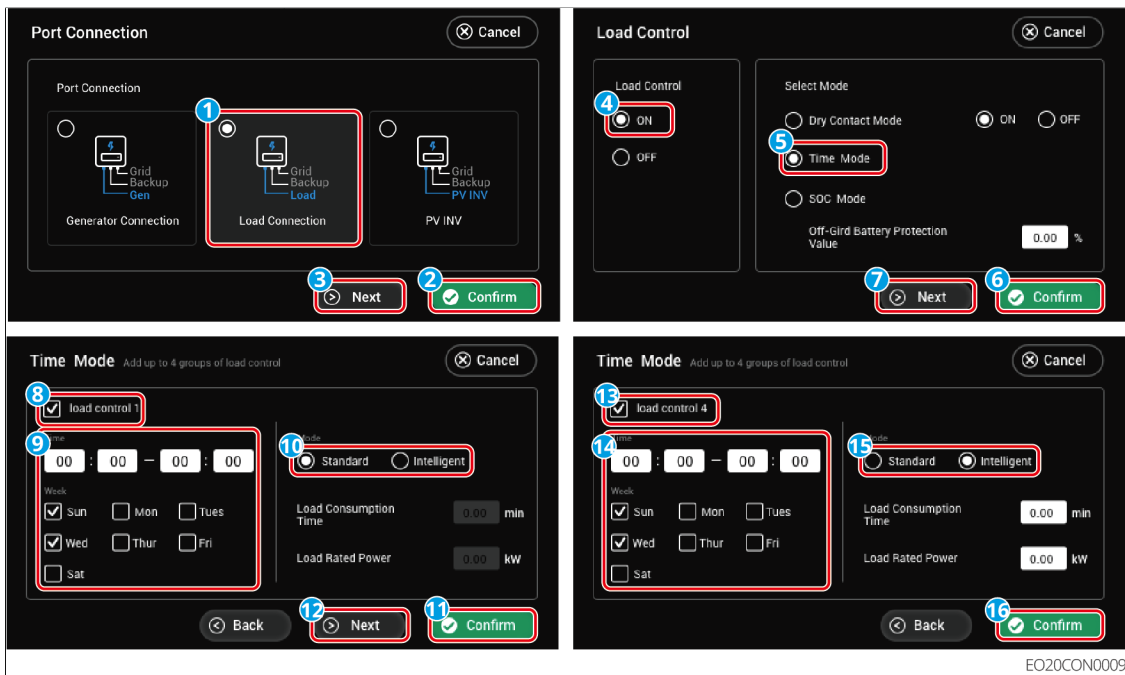
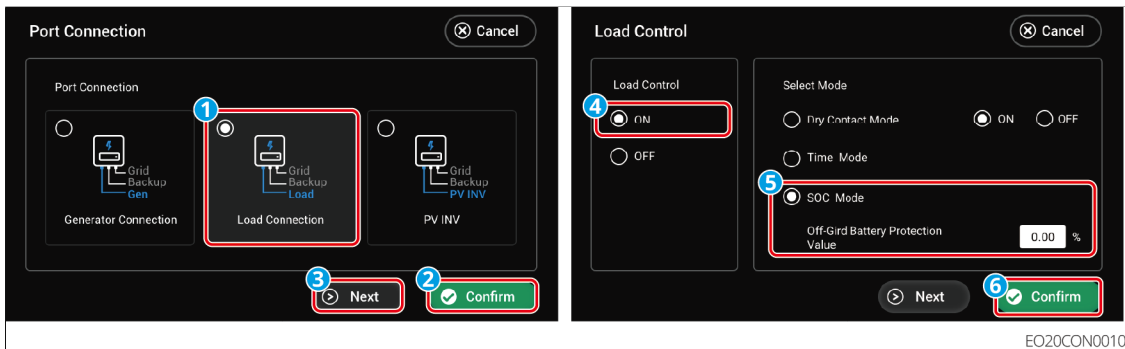

Figure61 Dry Node Mode



EO20CON0009

Figure62 Time Mode



EO20CON0010

Figure63 SOC Mode

No.	Parameter Name	Description
1	Load Control ON/OFF	Set the load control function ON/OFF
2	Dry Contact Mode	ON: Start supplying power to the load when the switch status is selected as ON. OFF: Stop supplying power to the load when the switch status is set to OFF.
3	Time Mode	Within the set time period, the load will automatically be powered on or off. You can choose Standard Mode or Smart Mode.

No.	Parameter Name	Description
4	Load Control 1	Set the time for the 1st group of load control. Up to 4 groups can be set.
5	Mode: Standard/Intelligent	Standard Mode: Will supply power to the load within the set time period. Smart Mode: Within the set time period, starts supplying power to the load when the surplus energy generated by PV exceeds the preset load rated power.
6	Load Consumption Time	The minimum runtime of the load after it is turned on, to avoid frequent switching due to energy fluctuations. Only applicable to Smart Mode.
7	Load Rated Power	When the surplus energy generated by PV exceeds this load rated power, it starts supplying power to the load. Only applicable to Smart Mode.
8	SOC Mode	The inverter's built-in relay dry contact control port can control whether to supply power to the load via the relay.
9	Off-Grid Battery Protection Value	In off-grid mode, if the BACK-UP terminal overload is detected or the battery SOC value is lower than the off-grid battery protection setting value, the power supply to the load connected to the relay port can be stopped. Please set the off-grid battery protection value according to actual needs.

## 7.2.7 Communication Settings

The inverter has built-in Bluetooth and WiFi signals, allowing you to restart the communication signal, reset communication configuration, and enable the Bluetooth signal.

1. From the main interface, click  > Quick Settings > Communication Module Settings to enter the parameter settings interface.
2. Please configure the parameters according to your actual setup.
3. After completing the settings, click Yes as prompted. The parameter setting is successful when the interface displays Confirm OK.

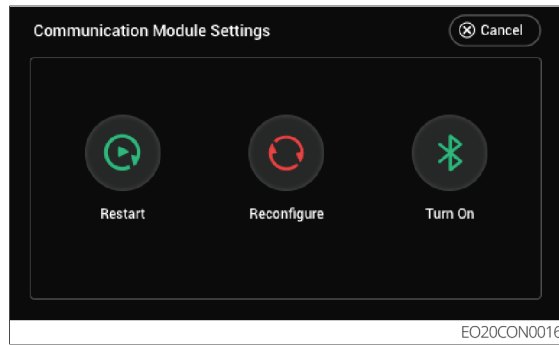

Figure64 Communication Settings

No.	Parameter Name	Description
1	Restart	Restarts the wireless signal.
2	Reconfigure	Restores communication to factory settings. To continue using the device, you need to reconfigure the WiFi connection information.
3	Turn On	Turns on the Bluetooth signal. The Bluetooth signal is turned on by default from the factory. After connecting to the app, follow the prompts to choose whether to keep it on. If you choose no, you need to turn it on again next time you connect the Bluetooth signal.

## 7.2.8 Viewing Device Information

1. Through the main interface, click  > Device Information to enter the parameter query interface.

### NOTICE

You can query the inverter serial number, DSP version, BMS version, LCD version, and ARM version.

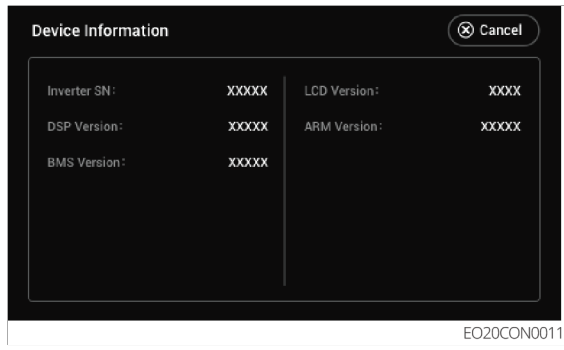

Figure65 Viewing Device Information

# 8 System Debugging and Power Station Monitoring

## 8.1 Setting Inverter Parameters via App

SEMS+ App is a software for remote power station monitoring or local device debugging. It supports installers or owners:

- Remotely monitor the operation status of the power station and set the operation parameters of the station and devices.
- Locally connect to devices, view device operation status, and set device parameters.

For detailed functions, please refer to the [SEMS+ App User Manual](#). The user manual can be obtained from the official website or by scanning the QR code below.



SEMS+ App User Manual

### 8.1.1 Download and Install the SEMS+ App

#### Phone Requirements:

- Operating System: Android 7.0 or later, iOS 15.1 or later.
- The phone supports a web browser and can connect to the Internet.
- The phone supports WLAN/Bluetooth functionality.

#### Download Methods:

##### Method 1:

Search for SEMS+ in the Google Play Store, App Store, Huawei AppGallery, Honor

AppGallery, Xiaomi App Store, OPPO App Market, or vivo App Store to download and install.



**Method 2:**

Scan the QR code below to download and install.

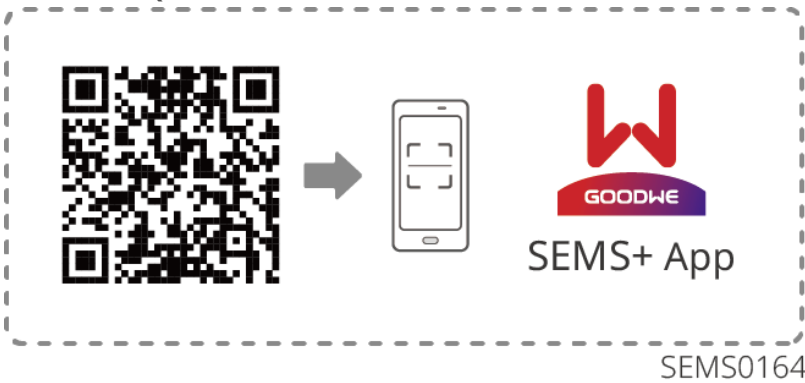

## 8.2 Monitoring Power Plants via SEMS+ WEB

SEMS+ WEB is a monitoring platform that can communicate via WiFi or LAN. The following are the common functions of SEMS+ WEB:

- 1. Manage organization or user information, etc.
- 2. Add, monitor power plant information, etc.
- 3. Maintain devices.

For detailed functions, please refer to the ["SEMS+ WEB User Manual"](#).



《SEMS+ WEB User Manual》

# 9 Maintenance

## 9.1 Power OFF the System

### DANGER

- When performing operation and maintenance on equipment within the system, please power down the system. Operating equipment while energized may cause equipment damage or risk of electric shock.
- After the equipment is powered off, internal components require a certain amount of time to discharge. Please wait until the equipment is completely discharged according to the time specified on the label.
- Restarting the battery should be performed using the air switch power-on method.
- When shutting down the battery system, strictly adhere to the battery system power-off requirements to prevent damage to the battery system.
- When there are multiple batteries in the system, powering off any one battery will power off all batteries.

### NOTICE

- The circuit breakers between the inverter and the battery, and between battery systems, must be installed in accordance with local laws and regulations.
- To ensure effective protection of the battery system, keep the cover plate of the battery system switch closed. The protective cover should automatically close after being opened. If the battery system switch will not be used for an extended period, secure it with screws.

#### Power OFF Procedure

1. Disconnect the BACK-UP breaker.
2. Disconnect the generator/heavy load switch.
3. Disconnect the ON-GRID breaker.
4. (Select according to local regulations) Disconnect the switch between the inverter

and the battery.

5. Power OFF the battery system:

- a. LX A5.0-10, LX A5.0-30: Press and hold the battery multifunction button for more than 5 seconds.
- b. GW16.1-BAT-LV-G10: Close the battery system integrated breaker or press and hold the battery system button for greater than or equal to 5 seconds, the battery system integrated breaker will automatically disconnect.

6. Disconnect the breaker between the PV modules and the inverter.

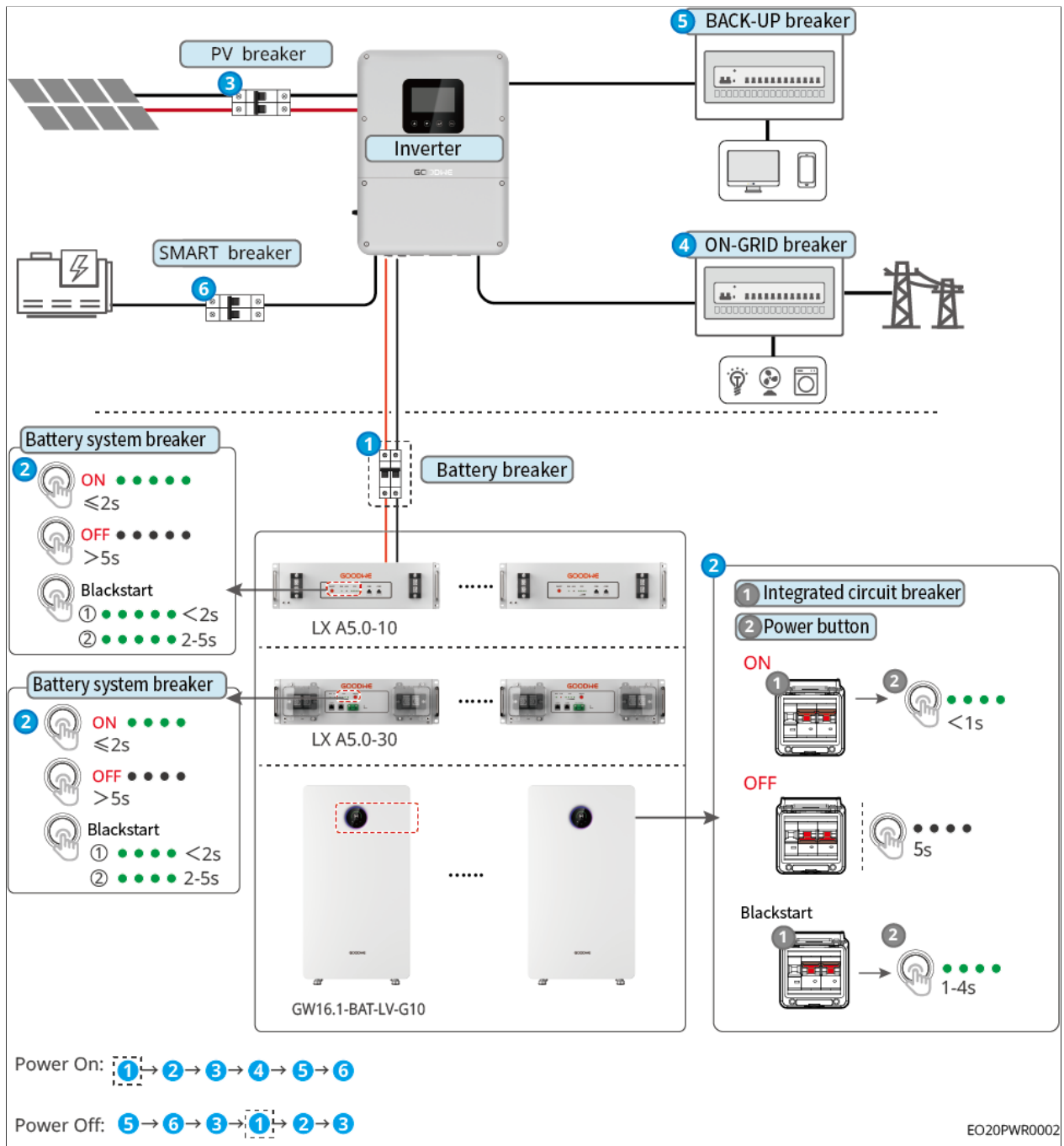

Figure66 System Power ON/OFF

## 9.2 Removing the Equipment



- Ensure the device is powered off.
- Wear personal protective equipment when operating the device.
- Use proper disassembly tools when removing wiring terminals to avoid damaging the terminals or the device.
- Unless otherwise specified, the device disassembly method is the reverse order of the installation method, which will not be reiterated in this document.

1. Power down the system.
2. Label the cable types for all connected cables in the system.
3. Disconnect the cables connected to the Inverter, Battery, and smart meter in the system, such as DC cables, AC cables, Communication cables, and PE cables.
4. Remove equipment such as the smart communication stick, Inverter, Battery, and smart meter.
5. Store the equipment properly. If it will be put into use later, ensure the storage conditions meet the requirements.

## 9.3 Disposing of the Equipment

When the equipment cannot continue to be used and needs to be disposed of, please dispose of it according to the electrical waste disposal requirements of the country/region where the equipment is located, and do not treat it as household waste.

## 9.4 Routine Maintenance



- If any issue that may affect the battery or energy storage inverter system is found, contact after-sales personnel. Disassembly by unauthorized personnel is strictly prohibited.
- If exposed copper wires are found inside the conductive cables, do not touch them. High voltage hazard. Contact after-sales personnel. Disassembly by unauthorized personnel is strictly prohibited.
- In case of any other emergencies, contact after-sales personnel immediately. Operate only under the guidance of after-sales personnel or wait for on-site operation by after-sales personnel.

Maintenance Item	Maintenance Method	Maintenance Cycle	Maintenance Purpose
System Cleaning	Check the heat sink, fan, and air intake/outlet vents for foreign objects and dust. Check if the installation space meets requirements, and check for any clutter accumulation around the equipment.	Once every six months	Prevent cooling failures.
System Installation	Check if the equipment installation is secure and if fastening screws are loose. Check the equipment exterior for damage or deformation.	Once every six months to once a year	Confirm equipment installation stability.
Electrical Connections	Check electrical connections for looseness, inspect cable exterior for damage, and check for exposed copper wires.	Once every six months to once a year	Confirm electrical connection reliability.
Sealing	Check if the sealing of the equipment cable entry holes meets requirements. If gaps are too large or unsealed, re-seal them.	Once a year	Confirm machine sealing and intact waterproof performance.

Maintenance Item	Maintenance Method	Maintenance Cycle	Maintenance Purpose
Battery Maintenance	If the battery has not been used for a long time or is not fully charged, it is recommended to charge the battery periodically.	Once every 15 days	Protect battery service life.

## 9.5 fault

### 9.5.1 Viewing Fault/Alarms Information

All detailed fault and alarm information for the energy storage system is displayed in the **SEMS+ App and SEMS+ WEB**. If your product is abnormal and you do not see relevant fault information in the **SEMS+ App or SEMS+ WEB**, please contact the after-sales service center.

- In the SEMS+ App

1. Open the SEMS+ App and log in with any account.
2. On the home page, click "Alarms" to view the alarm information for all power plants under the account.

- SEMS+ WEB

1. Open the SEMS+ WEB and log in with any account.
2. On the power plant details interface, click "Alarms" to view all alarm information for the current power plant.

### 9.5.2 Fault Information and Troubleshooting

Please follow the troubleshooting methods below. If these methods do not resolve the issue, please contact the after-sales service center.

When contacting the after-sales service center, please gather the following information to facilitate a quick resolution.

1. Product information, such as: serial number, software version, device installation time, fault occurrence time, fault frequency, etc.
2. Device installation environment, such as: weather conditions, whether components

are shaded or have shadows, etc. Providing photos or videos of the installation environment is recommended to assist in problem analysis.

3. Grid condition.

### 9.5.2.1 System Fault

If the system experiences a problem not listed, or if following the instructions does not prevent the issue or abnormality, immediately cease system operation and contact your dealer immediately.

No.	fault	Solution
1	Cannot find the Smart Communication Stick wireless signal	<ol style="list-style-type: none"> <li>1. Ensure no other device is connected to the Smart Communication Stick wireless signal.</li> <li>2. Ensure the App is upgraded to the latest version.</li> <li>3. Ensure the Smart Communication Stick is powered normally, with the blue signal light blinking or steady on.</li> <li>4. Ensure the smart device is within the communication range of the Smart Communication Stick.</li> <li>5. Refresh the App device list.</li> <li>6. Restart the inverter.</li> </ol>
2	Cannot connect to the Smart Communication Stick wireless signal	<ol style="list-style-type: none"> <li>1. Ensure no other device is connected to the Smart Communication Stick wireless signal.</li> <li>2. Restart the inverter or communication stick, and try connecting to the Smart Communication Stick wireless signal again.</li> <li>3. Ensure Bluetooth pairing and encryption are successful.</li> </ol>
3	Cannot find the router SSID	<ol style="list-style-type: none"> <li>1. Place the router closer to the Smart Communication Stick, or add a WiFi repeater to enhance the WiFi signal.</li> <li>2. Reduce the number of devices connected to the router.</li> </ol>

No.	fault	Solution
4	After all configuration is complete, the Smart Communication Stick fails to connect to the router	<ol style="list-style-type: none"> <li>1. Restart the inverter.</li> <li>2. Check if the network name, encryption method, and password in the WiFi configuration are the same as the router's.</li> <li>3. Restart the router.</li> <li>4. Place the router closer to the Smart Communication Stick, or add a WiFi repeater to enhance the WiFi signal.</li> </ol>
5	After all configuration is complete, the Smart Communication Stick fails to connect to the server	Restart the router and the inverter.

## 9.5.2.2 Inverter Fault

### 9.5.2.2.1 Troubleshooting (Fault Codes F01-F40)

Fault Code	Fault Name	Fault Cause	Troubleshooting Recommendation
F01	Grid Power Outage	<ol style="list-style-type: none"> <li>1. Grid power outage.</li> <li>2. AC line or AC switch is disconnected.</li> </ol>	<ol style="list-style-type: none"> <li>1. The alarm will disappear automatically after grid power supply is restored.</li> <li>2. Check whether the AC line or AC switch is disconnected.</li> </ol>

Fault Code	Fault Name	Fault Cause	Troubleshooting Recommendation
F02	Grid Overvoltage Protection	Grid voltage is higher than the allowable range, or the duration of high voltage exceeds the high voltage ride-through setting value.	<ol style="list-style-type: none"> <li>1. If it occurs occasionally, it may be a short-term grid abnormality. The inverter will resume normal operation after detecting that the grid is normal, requiring no manual intervention.</li> <li>2. If it occurs frequently, check whether the grid voltage is within the allowable range. If not, contact the local power operator. If it is, also modify the grid overvoltage protection point after obtaining consent from the local power operator.</li> <li>3. If it cannot recover for a long time, check whether the AC side circuit breaker and output cables are properly connected.</li> </ol>

Fault Code	Fault Name	Fault Cause	Troubleshooting Recommendation
F03	Grid Undervoltage Protection	Grid voltage is lower than the allowable range, or the duration of low voltage exceeds the low voltage ride-through setting value.	<ol style="list-style-type: none"> <li>1. If it occurs occasionally, it may be a short-term grid abnormality. The inverter will resume normal operation after detecting that the grid is normal, requiring no manual intervention.</li> <li>2. If it occurs frequently, check whether the grid voltage is within the allowable range. If not, contact the local power operator. If it is, also modify the grid undervoltage protection point after obtaining consent from the local power operator.</li> <li>3. If it cannot recover for a long time, check whether the AC side circuit breaker and output cables are properly connected.</li> </ol>

Fault Code	Fault Name	Fault Cause	Troubleshooting Recommendation
F04	Grid Rapid Overvoltage Protection	Abnormal grid voltage detection or ultra-high voltage triggers the fault.	<p>1. If it occurs occasionally, it may be a short-term grid abnormality. The inverter will resume normal operation after detecting that the grid is normal, requiring no manual intervention.</p> <p>2. If it occurs frequently, check whether the grid voltage is within the allowable range. If not, contact the local power operator. If it is, also modify the grid undervoltage protection point after obtaining consent from the local power operator.</p> <p>3. If it cannot recover for a long time, check whether the AC side circuit breaker and output cables are properly connected.</p>
F05	10min Overvoltage Protection	The moving average of grid voltage within 10min exceeds the range specified by safety regulations.	Check if the grid voltage has been operating at a high voltage for a long time. If it occurs frequently, check whether the grid frequency is within the allowable range. If not, contact the local power operator. If it is, also modify the grid 10min overvoltage protection point after obtaining consent from the local power operator.

Fault Code	Fault Name	Fault Cause	Troubleshooting Recommendation
F06	Grid Overfrequency	Grid abnormality: The actual grid frequency is higher than the local grid standard requirements.	<p>1. If it occurs occasionally, it may be a short-term grid abnormality. The inverter will resume normal operation after detecting that the grid is normal, requiring no manual intervention.</p> <p>2. If it occurs frequently, check whether the grid frequency is within the allowable range. If not, contact the local power operator. If it is, also modify the grid overfrequency protection point after obtaining consent from the local power operator.</p>
F07	Grid Underfrequency	Grid abnormality: The actual grid frequency is lower than the local grid standard requirements.	<p>1. If it occurs occasionally, it may be a short-term grid abnormality. The inverter will resume normal operation after detecting that the grid is normal, requiring no manual intervention.</p> <p>2. If it occurs frequently, check whether the grid frequency is within the allowable range. If not, contact the local power operator. If it is, also modify the grid overfrequency protection point after obtaining consent from the local power operator.</p>

Fault Code	Fault Name	Fault Cause	Troubleshooting Recommendation
F08	Grid Frequency Instability	Grid abnormality: The rate of change of the actual grid frequency does not comply with the local grid standard.	<p>1. If it occurs occasionally, it may be a short-term grid abnormality. The inverter will resume normal operation after detecting that the grid is normal, requiring no manual intervention.</p> <p>2. If it occurs frequently, check whether the grid frequency is within the allowable range. If not, contact the local power operator.</p>
F09	Anti-islanding Protection	The grid has been disconnected, but grid voltage is maintained due to the presence of loads. Grid connection is stopped according to safety regulation protection requirements.	<p>1. If it occurs occasionally, it may be a short-term grid abnormality. The inverter will resume normal operation after detecting that the grid is normal, requiring no manual intervention.</p> <p>2. If it occurs frequently, check whether the grid frequency is within the allowable range. If not, contact the local power operator.</p>
F10	LVRT Undervoltage Fault	Grid abnormality: The duration of abnormal grid voltage exceeds the time specified by the high/low voltage ride-through.	<p>1. If it occurs occasionally, it may be a short-term grid abnormality. The inverter will resume normal operation after detecting that the grid is normal, requiring no manual intervention.</p> <p>2. If it occurs frequently, check whether the grid voltage and frequency are within the allowable range and stable. If not, contact the local power operator.</p>

Fault Code	Fault Name	Fault Cause	Troubleshooting Recommendation
F11	HVRT Overvoltage	Grid abnormality: The duration of abnormal grid voltage exceeds the time specified by the high/low voltage ride-through.	<p>1. If it occurs occasionally, it may be a short-term grid abnormality. The inverter will resume normal operation after detecting that the grid is normal, requiring no manual intervention.</p> <p>2. If it occurs frequently, check whether the grid voltage and frequency are within the allowable range and stable. If not, contact the local power operator.</p>
F12	30mAGFCI Protection	The insulation impedance to ground of the input becomes low during inverter operation.	<p>1. If it occurs occasionally, it may be caused by occasional external line abnormalities. The inverter will resume normal operation after the fault is cleared, requiring no manual intervention.</p> <p>2. If it occurs frequently or cannot recover for a long time, check whether the insulation impedance to ground of the PV string is too low.</p>
F13	60mAGFCI Protection	The insulation impedance to ground of the input becomes low during inverter operation.	<p>1. If it occurs occasionally, it may be caused by occasional external line abnormalities. The inverter will resume normal operation after the fault is cleared, requiring no manual intervention.</p> <p>2. If it occurs frequently or cannot recover for a long time, check whether the insulation impedance to ground of the PV string is too low.</p>

Fault Code	Fault Name	Fault Cause	Troubleshooting Recommendation
F14	150mAGFCI Protection	The insulation impedance to ground of the input becomes low during inverter operation.	<p>1. If it occurs occasionally, it may be caused by occasional external line abnormalities. The inverter will resume normal operation after the fault is cleared, requiring no manual intervention.</p> <p>2. If it occurs frequently or cannot recover for a long time, check whether the insulation impedance to ground of the PV string is too low.</p>
F15	GFCI Gradual Change Protection	The insulation impedance to ground of the input becomes low during inverter operation.	<p>1. If it occurs occasionally, it may be caused by occasional external line abnormalities. The inverter will resume normal operation after the fault is cleared, requiring no manual intervention.</p> <p>2. If it occurs frequently or cannot recover for a long time, check whether the insulation impedance to ground of the PV string is too low.</p>
F16	DCI Level 1 Protection	The DC component of the inverter output current is higher than the range allowed by safety regulations or the machine default.	<p>1. If it is caused by an abnormality introduced by an external fault, the inverter will automatically resume normal operation after the fault disappears, requiring no manual intervention.</p> <p>2. If this alarm occurs frequently, affecting the normal power generation of the power station, contact the distributor or after-sales service center.</p>

Fault Code	Fault Name	Fault Cause	Troubleshooting Recommendation
F17	DCI Level 2 Protection	The DC component of the inverter output current is higher than the range allowed by safety regulations or the machine default.	<p>1. If it is caused by an abnormality introduced by an external fault, the inverter will automatically resume normal operation after the fault disappears, requiring no manual intervention.</p> <p>2. If this alarm occurs frequently, affecting the normal power generation of the power station, contact the distributor or after-sales service center.</p>

Fault Code	Fault Name	Fault Cause	Troubleshooting Recommendation
F18	Low Insulation Resistance	<ol style="list-style-type: none"> <li>1. PV string short-circuited to protective earth.</li> <li>2. The PV string is installed in a long-term humid environment with poor line-to-ground insulation.</li> <li>3. Low insulation impedance to ground of the battery port lines.</li> </ol>	<ol style="list-style-type: none"> <li>1. Check the impedance of the PV string/battery port to protective earth. A value greater than 80kΩ is normal. If the checked value is less than 80kΩ, locate and rectify the short circuit point.</li> <li>2. Check whether the inverter's protective earth wire is correctly connected.</li> <li>3. If it is confirmed that the impedance is indeed lower than the default value in rainy weather, reset the inverter's "Insulation Resistance Protection Point" via the App. For inverters in the Australian and New Zealand markets, when an insulation resistance fault occurs, it can also be alerted in the following ways: <ol style="list-style-type: none"> <li>1. The inverter is equipped with a buzzer. When a fault occurs, the buzzer sounds continuously for 1 minute; if the fault is not resolved, the buzzer sounds again every 30 minutes.</li> <li>2. If the inverter is added to the monitoring platform and the alarm notification method is set, the alarm information can be sent to the customer via email.</li> </ol> </li> </ol>

Fault Code	Fault Name	Fault Cause	Troubleshooting Recommendation
F19	Grounding Abnormal	1. The inverter's protective earth wire is not connected. 2. When the PV string output is grounded, the inverter output side is not connected to an isolation transformer.	1. Please confirm whether the inverter's protective earth wire is not properly connected. 2. In scenarios where the PV string output is grounded, please confirm whether an isolation transformer is connected to the inverter output side.
F20	Hard Anti-backflow Protection	Load abnormal fluctuation	1. If it is caused by an abnormality introduced by an external fault, the inverter will automatically resume normal operation after the fault disappears, requiring no manual intervention. 2. If this alarm occurs frequently, affecting the normal power generation of the power station, contact the distributor or after-sales service center.

Fault Code	Fault Name	Fault Cause	Troubleshooting Recommendation
F21	Internal Comm Loss	Slave DSP1 communication timeout - Master DSP, Slave DSP2 communication timeout - Master DSP, Slave DSP2 communication timeout - Slave DSP1, Master DSP communication timeout - Slave DSP1, Master DSP communication timeout - Slave DSP2, or Slave DSP1 communication timeout - Slave DSP2: 1. Chip not powered on 2. Chip program version error	Disconnect the AC output side switch and DC input side switch, wait for 5 minutes, then close the AC output side switch and DC input side switch. If the fault still exists, contact the distributor or after-sales service center.

Fault Code	Fault Name	Fault Cause	Troubleshooting Recommendation
		Master DSP CAN module error, Slave DSP1 CAN module error, or Slave DSP2 CAN module error: 1. Frame format error 2. Parity check error 3. CAN bus offline 4. Hardware CRC check error 5. Control bit is receive (transmit) when transmitting (receiving) 6. Transmission to a unit not permitted	
F22	Generator Waveform Detection Fault	1. This fault will be displayed continuously when the generator is not connected; 2. When the generator is operating, failure to meet generator safety regulations will trigger this fault.	
F23	Generator Abnormal Connection		
F24	Generator Voltage Low		
F25	Generator Voltage High		
F26	Generator Frequency Low		

Fault Code	Fault Name	Fault Cause	Troubleshooting Recommendation
F27	Generator Frequency High		<p>1. Ignore this fault when the generator is not connected;</p> <p>2. When this fault appears due to a generator fault, it is normal. Wait for a period after the generator recovers, and the fault will be cleared automatically;</p> <p>3. This fault will not affect the normal operation of the off-grid mode.</p> <p>4. When both the generator and the grid are connected and meet safety regulation requirements, the grid has priority for grid connection, and the system will operate in grid-connected state.</p>
F28	Parallel Unit I/O Self-check Abnormal	Parallel communication cable is not securely connected or parallel IO chip is damaged	Check whether the parallel communication cable is securely connected, then check whether the IO chip is damaged. If yes, replace the IO chip.
F29	Parallel Grid Line Reversed	Some machines' grid lines are reversed with others	Reconnect the grid lines
F30	AC HCT check Abnormal	AC sensor has sampling abnormality	Disconnect the AC output side switch and DC input side switch, wait for 5 minutes, then close the AC output side switch and DC input side switch. If the fault still exists, contact the distributor or after-sales service center.

<b>Fault Code</b>	<b>Fault Name</b>	<b>Fault Cause</b>	<b>Troubleshooting Recommendation</b>
F31	GFCI HCT Check Abnormal	Leakage current sensor has sampling abnormality	Disconnect the AC output side switch and DC input side switch, wait for 5 minutes, then close the AC output side switch and DC input side switch. If the fault still exists, contact the distributor or after-sales service center.
F32	Inverter Internal Failure	Inverter has a fault	Disconnect the AC output side switch and DC input side switch, wait for 5 minutes, then close the AC output side switch and DC input side switch. If the fault still exists, contact the distributor or after-sales service center.
F33	Flash Read/Write Error	Possible causes: Flash content changed; Flash life exhausted;	1. Upgrade to the latest program version. 2. Contact the distributor or after-sales service center.
F34	AFCI Check Failure	The arc fault module did not detect an arc fault during the arc self-check process.	Disconnect the AC output side switch and DC input side switch, wait for 5 minutes, then close the AC output side switch and DC input side switch. If the fault still exists, contact the distributor or after-sales service center.

Fault Code	Fault Name	Fault Cause	Troubleshooting Recommendation
F35	Cabinet Overtemperature	<p>Cabinet temperature is too high, possible causes:</p> <ol style="list-style-type: none"> <li>1. Inverter installation location is not ventilated.</li> <li>2. Ambient temperature is too high.</li> <li>3. Internal fan operation is abnormal.</li> </ol>	<ol style="list-style-type: none"> <li>1. Check whether the ventilation at the inverter installation location is good and whether the ambient temperature exceeds the maximum allowable ambient temperature range.</li> <li>2. If it is not ventilated or the ambient temperature is too high, improve its ventilation and heat dissipation conditions.</li> <li>3. If ventilation and ambient temperature are normal, contact the distributor or after-sales service center.</li> </ol>

Fault Code	Fault Name	Fault Cause	Troubleshooting Recommendation
F36	Bus Overvoltage	<p>BUS overvoltage, possible causes:</p> <ol style="list-style-type: none"> <li>1. PV voltage is too high;</li> <li>2. Inverter BUS voltage sampling is abnormal;</li> <li>3. The isolation effect of the dual-split transformer at the inverter's rear end is poor, causing mutual influence when two inverters are connected in parallel, with one inverter reporting DC overvoltage during grid connection;</li> </ol>	<p>Disconnect the AC output side switch and DC input side switch, wait for 5 minutes, then close the AC output side switch and DC input side switch. If the fault still exists, contact the distributor or after-sales service center.</p>

Fault Code	Fault Name	Fault Cause	Troubleshooting Recommendation
F37	PV Input Overvoltage	<p>PV input voltage is too high, possible cause:            PV array configuration error. Too many PV panels are connected in series in a string, causing the string's open-circuit voltage to be higher than the inverter's maximum operating voltage.</p>	<p>Check the series configuration of the corresponding PV array string to ensure the string's open-circuit voltage is not higher than the inverter's maximum operating voltage. After the PV array is configured correctly, the inverter alarm will disappear automatically.</p>
F38	PV Persistent Hardware Overcurrent	<ol style="list-style-type: none"> <li>1. Module configuration is unreasonable.</li> <li>2. Hardware damage.</li> </ol>	<p>Disconnect the AC output side switch and DC input side switch, wait for 5 minutes, then close the AC output side switch and DC input side switch. If the fault still exists, contact the distributor or after-sales service center.</p>
F39	PV Persistent Software Overcurrent	<ol style="list-style-type: none"> <li>1. Module configuration is unreasonable.</li> <li>2. Hardware damage.</li> </ol>	<p>Disconnect the AC output side switch and DC input side switch, wait for 5 minutes, then close the AC output side switch and DC input side switch. If the fault still exists, contact the distributor or after-sales service center.</p>

<b>Fault Code</b>	<b>Fault Name</b>	<b>Fault Cause</b>	<b>Troubleshooting Recommendation</b>
F40, F98	String Reverse Connection (String 1-n) n: Determined based on the actual number of inverter strings.	PV string reverse connection	Check if the string is reversely connected.

#### 9.5.2.2.2 Troubleshooting (Error Codes F41-F80)

<b>Fault Code</b>	<b>Fault Name</b>	<b>Fault Cause</b>	<b>Troubleshooting Recommendation</b>
F41	Generator Port Overload	<ol style="list-style-type: none"> <li>1. Off-grid side output exceeds specifications.</li> <li>2. Off-grid side short circuit.</li> <li>3. Off-grid side voltage too low.</li> <li>4. When used as a heavy-load port, the heavy load exceeds specifications.</li> </ol>	Verify the off-grid side output voltage, current, power, and other data to identify the cause of the issue.

Fault Code	Fault Name	Fault Cause	Troubleshooting Recommendation
F42	DC Arcing Failure (String 1-n) n: Determined by the actual number of inverter strings.	<ol style="list-style-type: none"> <li>1. Loose DC side connection terminals.</li> <li>2. Poor contact at DC side connection terminals.</li> <li>3. Damaged DC cable cores causing poor contact.</li> </ol>	<ol style="list-style-type: none"> <li>1. After the unit reconnects to the grid, check if the voltage and current of each string abnormally decrease or become zero.</li> <li>2. Check if the DC side terminals are securely connected.</li> </ol>
F43	Grid Waveform Abnormal	Utility grid abnormality: Abnormal grid voltage detection triggers the fault.	<ol style="list-style-type: none"> <li>1. If it occurs occasionally, it may be due to a temporary grid anomaly. The inverter will resume normal operation after detecting a normal grid, requiring no manual intervention.</li> <li>2. If it occurs frequently, check if the grid voltage and frequency are within the allowable range and stable. If not, contact the local power operator.</li> </ol>
F44	Grid Phase Loss	Utility grid abnormality: Single-phase voltage drop in the grid.	<ol style="list-style-type: none"> <li>1. If it occurs occasionally, it may be due to a temporary grid anomaly. The inverter will resume normal operation after detecting a normal grid, requiring no manual intervention.</li> <li>2. If it occurs frequently, check if the grid voltage and frequency are within the allowable range and stable. If not, contact the local power operator.</li> </ol>

<b>Fault Code</b>	<b>Fault Name</b>	<b>Fault Cause</b>	<b>Troubleshooting Recommendation</b>
F45	Grid Voltage Imbalance	Excessive difference in grid phase voltages.	<p>1. If it occurs occasionally, it may be due to a temporary grid anomaly. The inverter will resume normal operation after detecting a normal grid, requiring no manual intervention.</p> <p>2. If it occurs frequently, check if the grid voltage and frequency are within the allowable range and stable. If not, contact the local power operator.</p>
F46	Grid Phase Sequence Failure	Inverter and grid wiring anomaly: Wiring is not in positive sequence.	<p>1. Check if the inverter and grid wiring are in positive sequence. The fault will automatically clear after correct wiring (e.g., swapping any two live wires).</p> <p>2. If the fault persists despite correct wiring, contact the dealer or after-sales service center.</p>
F47	Grid Rapid Shutdown Protection	Quickly shuts down output after detecting a grid power outage condition.	Fault automatically clears after grid power supply is restored.
F48	Grid Neutral Wire Loss (Split-phase Grid)	Neutral wire loss in a split-phase grid.	<p>1. The alarm automatically clears after grid power supply is restored.</p> <p>2. Check if the AC line or AC switch is disconnected.</p>
F49	L-PE Short Circuit	Low impedance or short circuit between output phase line and PE.	Measure the impedance between the output phase line and PE, locate the point with low impedance, and repair it.

<b>Fault Code</b>	<b>Fault Name</b>	<b>Fault Cause</b>	<b>Troubleshooting Recommendation</b>
F50	DCV Level 1 Protection	Abnormal load fluctuation.	<p>1. If caused by an external fault, the inverter will automatically resume normal operation after the fault disappears, requiring no manual intervention.</p> <p>2. If this alarm occurs frequently and affects normal power generation, contact the dealer or after-sales service center.</p>
F51	DCV Level 2 Protection	Abnormal load fluctuation.	
F52	Leakage current (GFCI) Multiple Fault Shutdown	North American safety regulations require manual recovery or waiting 24h after multiple faults, no automatic recovery.	Please check if the PV string's impedance to ground is too low.
F53	DC Arcing (AFCI) Multiple Fault Shutdown	North American safety regulations require manual recovery or waiting 24h after multiple faults, no automatic recovery.	<p>1. After the unit reconnects to the grid, check if the voltage and current of each string abnormally decrease or become zero.</p> <p>2. Check if the DC side terminals are securely connected.</p>
F54	External Communication Link Loss	Inverter external device communication loss, possibly due to peripheral power supply issues, communication protocol mismatch, or unconfigured peripherals.	Determine based on the actual model and detection enable bits. Some models do not support certain peripherals and will not detect them.

<b>Fault Code</b>	<b>Fault Name</b>	<b>Fault Cause</b>	<b>Troubleshooting Recommendation</b>
F55	Back-up Port Overload Fault	Prevents the inverter from continuously outputting overload.	Turn off some off-grid loads to reduce the inverter's off-grid output power.
F56	Back-up Port Overvoltage Fault	Prevents inverter output overvoltage from damaging loads.	<ol style="list-style-type: none"> <li>1. If it occurs occasionally, it may be due to load switching and requires no manual intervention.</li> <li>2. If it occurs frequently, contact the dealer or after-sales service center.</li> </ol>
F57	External Box Fault	Waiting too long for the Box to switch relays during grid-to-off-grid transition.	<ol style="list-style-type: none"> <li>1. Check if the Box is functioning normally.</li> <li>2. Check if the Box communication wiring is correct.</li> </ol>
F58	CT Loss Fault	CT connection wire disconnected (Japanese safety regulation requirement).	Check if the CT wiring is correct.
F59	Parallel Unit CAN Communication Abnormal	Parallel communication cable not securely connected or some units offline.	Check if all units are powered on and if the parallel communication cables are securely connected.
F60	Parallel Unit Back-up Connection Reversed	Some units' backup lines are reversed with others.	Reconnect the backup lines.
F61	Inverter Soft Start Failure	Inverter soft start failure during off-grid cold start.	Check if the inverter module is damaged.

<b>Fault Code</b>	<b>Fault Name</b>	<b>Fault Cause</b>	<b>Troubleshooting Recommendation</b>
F62	AC HCT Failure	Abnormality in the HCT sensor.	Disconnect the AC output side switch and DC input side switch, wait 5 minutes, then close the AC output side switch and DC input side switch. If the fault persists, contact the dealer or after-sales service center.
F63	GFCI HCT Failure	Abnormality in the leakage current sensor.	Disconnect the AC output side switch and DC input side switch, wait 5 minutes, then close the AC output side switch and DC input side switch. If the fault persists, contact the dealer or after-sales service center.
F64	Inverter Internal Failure	Inverter fault exists.	Disconnect the AC output side switch and DC input side switch, wait 5 minutes, then close the AC output side switch and DC input side switch. If the fault persists, contact the dealer or after-sales service center.
F65	AC Terminal Overtemperature	AC terminal temperature too high, possible causes: 1. Inverter installation location lacks ventilation. 2. Ambient temperature too high. 3. Internal fan operation abnormal.	1. Check if the inverter installation location has good ventilation and if the ambient temperature exceeds the maximum allowable range. 2. If ventilation is poor or ambient temperature is too high, improve ventilation and heat dissipation conditions. 3. If ventilation and ambient temperature are normal, contact the dealer or after-sales service center.

Fault Code	Fault Name	Fault Cause	Troubleshooting Recommendation
F66	INV Module Overtemperature	Inverter module temperature too high, possible causes: 1. Inverter installation location lacks ventilation. 2. Ambient temperature too high. 3. Internal fan operation abnormal.	1. Check if the inverter installation location has good ventilation and if the ambient temperature exceeds the maximum allowable range. 2. If ventilation is poor or ambient temperature is too high, improve ventilation and heat dissipation conditions. 3. If ventilation and ambient temperature are normal, contact the dealer or after-sales service center.
F67	Boost Module Overtemperature	Boost module temperature too high, possible causes: 1. Inverter installation location lacks ventilation. 2. Ambient temperature too high. 3. Internal fan operation abnormal.	1. Check if the inverter installation location has good ventilation and if the ambient temperature exceeds the maximum allowable range. 2. If ventilation is poor or ambient temperature is too high, improve ventilation and heat dissipation conditions. 3. If ventilation and ambient temperature are normal, contact the dealer or after-sales service center.

<b>Fault Code</b>	<b>Fault Name</b>	<b>Fault Cause</b>	<b>Troubleshooting Recommendation</b>
F68	AC Capacitor Overtemperature	Output filter capacitor temperature too high, possible causes: 1. Inverter installation location lacks ventilation. 2. Ambient temperature too high. 3. Internal fan operation abnormal.	1. Check if the inverter installation location has good ventilation and if the ambient temperature exceeds the maximum allowable range. 2. If ventilation is poor or ambient temperature is too high, improve ventilation and heat dissipation conditions. 3. If ventilation and ambient temperature are normal, contact the dealer or after-sales service center.
F69	PV IGBT Short Circuit Fault	Possible causes: 1. IGBT short circuit 2. Inverter sampling circuit abnormal	Disconnect the AC output side switch and DC input side switch, wait 5 minutes, then close the AC output side switch and DC input side switch. If the fault persists, contact the dealer or after-sales service center.
F70	PV IGBT Open Circuit Fault	1. Software issue causing no PWM generation. 2. Drive circuit abnormal. 3. IGBT open circuit.	
F71	NTC Abnormal	NTC temperature sensor abnormal.	Disconnect the AC output side switch and DC input side switch, wait 5 minutes, then close the AC output side switch and DC input side switch. If the fault persists, contact the dealer or after-sales service center.

<b>Fault Code</b>	<b>Fault Name</b>	<b>Fault Cause</b>	<b>Troubleshooting Recommendation</b>
F72	PWM Abnormal	Abnormal PWM waveform.	Disconnect the AC output side switch and DC input side switch, wait 5 minutes, then close the AC output side switch and DC input side switch. If the fault persists, contact the dealer or after-sales service center.
F73	CPU Interrupt Abnormal	CPU interrupt abnormal.	Disconnect the AC output side switch and DC input side switch, wait 5 minutes, then close the AC output side switch and DC input side switch. If the fault persists, contact the dealer or after-sales service center.
F74	Microelectronics Fault	Functional safety detection detected an abnormality.	Disconnect the AC output side switch and DC input side switch, wait 5 minutes, then close the AC output side switch and DC input side switch. If the fault persists, contact the dealer or after-sales service center.
F75	PV HCT Fault	boost current sensor abnormal.	Disconnect the AC output side switch and DC input side switch, wait 5 minutes, then close the AC output side switch and DC input side switch. If the fault persists, contact the dealer or after-sales service center.
F76	1.5V Reference Abnormal	Reference circuit fault.	Disconnect the AC output side switch and DC input side switch, wait 5 minutes, then close the AC output side switch and DC input side switch. If the fault persists, contact the dealer or after-sales service center.
F77	0.3V Reference Abnormal	Reference circuit fault.	
F78	CPLD Version Recognition Error	CPLD version recognition error.	Disconnect the AC output side switch and DC input side switch, wait 5 minutes, then close the AC output side switch and DC input side switch. If the fault persists, contact the dealer or after-sales service center.

<b>Fault Code</b>	<b>Fault Name</b>	<b>Fault Cause</b>	<b>Troubleshooting Recommendation</b>
F79	CPLD Communication Fault	CPLD and DSP communication content error or timeout.	Disconnect the AC output side switch and DC input side switch, wait 5 minutes, then close the AC output side switch and DC input side switch. If the fault persists, contact the dealer or after-sales service center.
F80	Model Identification Fault	Fault related to model identification error.	Disconnect the AC output side switch and DC input side switch, wait 5 minutes, then close the AC output side switch and DC input side switch. If the fault persists, contact the dealer or after-sales service center.

#### 9.5.2.2.3 Troubleshooting (Fault Codes F81-F121)

<b>Fault Code</b>	<b>Fault Name</b>	<b>Possible Cause</b>	<b>Troubleshooting Suggestions</b>
F81	P-Bus Overvoltage		Disconnect the AC output side switch and the DC input side switch, wait for 5 minutes, then close the AC output side switch and the DC input side switch. If the fault persists, please contact the dealer or after-sales service center.

Fault Code	Fault Name	Possible Cause	Troubleshooting Suggestions
F82	N-Bus Overvoltage	BUS overvoltage, possible causes: 1. PV voltage is too high; 2. Inverter BUS voltage sampling is abnormal; 3. Poor isolation effect of the dual-split transformer at the inverter's rear end, causing mutual interference when two inverters are grid-connected, with one inverter reporting a DC overvoltage during grid connection;	
F83	Bus Overvoltage (Sub CPU1)		Disconnect the AC output side switch and the DC input side switch, wait for 5 minutes, then close the AC output side switch and the DC input side switch. If the fault persists, please contact the dealer or after-sales service center.
F84	P-Bus Overvoltage (Sub CPU1)		

Fault Code	Fault Name	Possible Cause	Troubleshooting Suggestions
F85	N-Bus Overvoltage (Sub CPU1)	BUS overvoltage, possible causes: 1. PV voltage is too high; 2. Inverter BUS voltage sampling is abnormal; 3. Poor isolation effect of the dual-split transformer at the inverter's rear end, causing mutual interference when two inverters are grid-connected, with one inverter reporting a DC overvoltage during grid connection;	
F86	Bus Overvoltage (Sub CPU2)		Disconnect the AC output side switch and the DC input side switch, wait for 5 minutes, then close the AC output side switch and the DC input side switch. If the fault persists, please contact the dealer or after-sales service center.
F87	P-Bus Overvoltage (Sub CPU2)		

Fault Code	Fault Name	Possible Cause	Troubleshooting Suggestions
F88	N-Bus Overvoltage (Sub CPU2)	BUS overvoltage, possible causes: 1. PV voltage is too high; 2. Inverter BUS voltage sampling is abnormal; 3. Poor isolation effect of the dual-split transformer at the inverter's rear end, causing mutual interference when two inverters are grid-connected, with one inverter reporting a DC overvoltage during grid connection;	
F89	P-Bus Overvoltage (CPLD)		Disconnect the AC output side switch and the DC input side switch, wait for 5 minutes, then close the AC output side switch and the DC input side switch. If the fault persists, please contact the dealer or after-sales service center.

Fault Code	Fault Name	Possible Cause	Troubleshooting Suggestions
F90	N-Bus Overvoltage(CPLD)	BUS overvoltage, possible causes: 1. PV voltage is too high; 2. Inverter BUS voltage sampling is abnormal; 3. Poor isolation effect of the dual-split transformer at the inverter's rear end, causing mutual interference when two inverters are grid-connected, with one inverter reporting a DC overvoltage during grid connection;	
F91	FlyCap Software Overvoltage	FlyCap overvoltage, possible causes: 1. PV voltage is too high; 2. Inverter FlyCap voltage sampling is abnormal;	Disconnect the AC output side switch and the DC input side switch, wait for 5 minutes, then close the AC output side switch and the DC input side switch. If the fault persists, please contact the dealer or after-sales service center.
F92	FlyCap Hardware Overvoltage		

Fault Code	Fault Name	Possible Cause	Troubleshooting Suggestions
F93	FlyCap Undervoltage	FlyCap undervoltage, possible causes: 1. PV energy is insufficient; 2. Inverter FlyCap voltage sampling is abnormal;	Disconnect the AC output side switch and the DC input side switch, wait for 5 minutes, then close the AC output side switch and the DC input side switch. If the fault persists, please contact the dealer or after-sales service center.
F94	FlyCap Precharge Failure	FlyCap precharge failure, possible causes: 1. PV energy is insufficient; 2. Inverter FlyCap voltage sampling is abnormal;	Disconnect the AC output side switch and the DC input side switch, wait for 5 minutes, then close the AC output side switch and the DC input side switch. If the fault persists, please contact the dealer or after-sales service center.
F95	FlyCap Precharge Abnormal	1. Control loop parameters are unreasonable. 2. Hardware damage.	Disconnect the AC output side switch and the DC input side switch, wait for 5 minutes, then close the AC output side switch and the DC input side switch. If the fault persists, please contact the dealer or after-sales service center.

Fault Code	Fault Name	Possible Cause	Troubleshooting Suggestions
F96, F97	String Overcurrent(String 1-n) n: Determined based on the actual number of inverter strings.	Possible causes: 1. String overcurrent; 2. String current sensor is abnormal.	Disconnect the AC output side switch and the DC input side switch, wait for 5 minutes, then close the AC output side switch and the DC input side switch. If the fault persists, please contact the dealer or after-sales service center.
F99, F100	String Loss(String 1-n) n: Determined based on the actual number of inverter strings.	String fuse is open (if present).	Check if the fuse is open.
F101	Battery 1 Precharge fault	Battery 1 precharge circuit fault (precharge resistor burnt out, etc.)	Check if the precharge circuit is in good condition. After only the battery is powered on, check if the battery voltage and bus voltage are consistent. If not consistent, please contact the dealer or after-sales service center.
F102	Battery 1 Relay Failure	Battery 1 relay cannot operate normally.	After the battery is powered on, check if the battery relay is working, and if a closing sound is heard. If it does not operate, please contact the dealer or after-sales service center.

<b>Fault Code</b>	<b>Fault Name</b>	<b>Possible Cause</b>	<b>Troubleshooting Suggestions</b>
F103	Battery 1 Connection Overvoltage	Battery 1 connection voltage exceeds the machine's rated range.	Confirm if the battery voltage is within the machine's rated range.
F104	Battery 2 Precharge fault	Battery 2 precharge circuit fault (precharge resistor burnt out, etc.)	Check if the precharge circuit is in good condition. After only the battery is powered on, check if the battery voltage and bus voltage are consistent. If not consistent, please contact the dealer or after-sales service center.
F105	Battery 2 Relay Failure	Battery 2 relay cannot operate normally.	After the battery is powered on, check if the battery relay is working, and if a closing sound is heard. If it does not operate, please contact the dealer or after-sales service center.
F106	Battery 2 Connection Overvoltage	Battery 2 connection voltage exceeds the machine's rated range.	Confirm if the battery voltage is within the machine's rated range.
F107	On-grid PWM Sync Failure	Abnormal carrier synchronization during grid connection.	<ol style="list-style-type: none"> <li>1. Check if the sync line connection is normal.</li> <li>2. Check if the master/slave settings are normal;</li> <li>3. Disconnect the AC output side switch and the DC input side switch, wait for 5 minutes, then close the AC output side switch and the DC input side switch. If the fault persists, please contact the dealer or after-sales service center.</li> </ol>

<b>Fault Code</b>	<b>Fault Name</b>	<b>Possible Cause</b>	<b>Troubleshooting Suggestions</b>
F108	DSP Communication fault	-	-
F109	External STS fault	Abnormal cable connection between the inverter and the STS.	Check if the wiring harness connection sequence between the inverter and the STS corresponds one-to-one in order.
F110	Export Limit Protection	<ol style="list-style-type: none"> <li>1. The inverter reports an error and disconnects from the grid.</li> <li>2. meter communication is unstable.</li> <li>3. Reverse power flow condition occurs.</li> </ol>	<ol style="list-style-type: none"> <li>1. Check if there are other error messages from the inverter. If yes, handle them accordingly.</li> <li>2. Check if the meter connection is reliable.</li> <li>3. If this alarm occurs frequently, affecting normal power plant generation, please contact the dealer or after-sales service center.</li> </ol>
F111	Bypass Overload	-	-
F112	Black Start Failure	-	-
F113	Offgrid AC Ins Volt High	-	-

Fault Code	Fault Name	Possible Cause	Troubleshooting Suggestions
F114	Relay Failure2	Relay abnormality, causes: 1. Relay abnormality (relay short circuit). 2. Relay sampling circuit abnormality. 3. AC side wiring abnormality (possible loose connection or short circuit).	Disconnect the AC output side switch and the DC input side switch, wait for 5 minutes, then close the AC output side switch and the DC input side switch. If the fault persists, please contact the dealer or after-sales service center.
F115	SVG Precharge Disabled	SVG precharge hardware failure.	Contact the dealer or after-sales service center.
F116	Nighttime SVG PID Prevention fault	PID prevention hardware abnormality.	
F117	DSP Version Identification Error	DSP software version identification error.	Disconnect the AC output side switch and the DC input side switch, wait for 5 minutes, then close the AC output side switch and the DC input side switch. If the fault persists, please contact the dealer or after-sales service center.

<b>Fault Code</b>	<b>Fault Name</b>	<b>Possible Cause</b>	<b>Troubleshooting Suggestions</b>
F118	MOS Continuous Overvoltage	<ol style="list-style-type: none"> <li>1. Software issue causes inverter drive to turn off earlier than the flyback drive.</li> <li>2. Inverter drive circuit abnormality prevents turn-on.</li> <li>3. PV voltage is too high.</li> <li>4. Mos voltage sampling is abnormal.</li> </ol>	<p>Disconnect the AC output side switch and the DC input side switch, wait for 5 minutes, then close the AC output side switch and the DC input side switch. If the fault persists, please contact the dealer or after-sales service center.</p>
F119	Bus Short Circuit fault	Hardware damage.	<p>If the inverter remains offline continuously after a BUS short circuit fault occurs, please contact the dealer or after-sales service center.</p>
F120	Bus Sampling Abnormality	<ol style="list-style-type: none"> <li>1. BUS voltage sampling hardware fault.</li> </ol>	<p>Disconnect the AC output side switch and the DC input side switch, wait for 5 minutes, then close the AC output side switch and the DC input side switch. If the fault persists, please contact the dealer or after-sales service center.</p>
F121	DC Side Sampling Abnormality	<ol style="list-style-type: none"> <li>1. BUS voltage sampling hardware fault.</li> <li>2. Battery voltage sampling hardware fault.</li> <li>3. Dcrlly relay fault.</li> </ol>	<p>Disconnect the AC output side switch and the DC input side switch, wait for 5 minutes, then close the AC output side switch and the DC input side switch. If the fault persists, please contact the dealer or after-sales service center.</p>

Fault Code	Fault Name	Possible Cause	Troubleshooting Suggestions
F122	PV Access Mode Setting Error	<p>There are three PV access modes, taking four MPPT channels as an example:</p> <ol style="list-style-type: none"> <li>1. Parallel mode: i.e., AAAA mode (same-source mode), PV1-PV4 are from the same source, all 4 PV channels connect to the same solar panel.</li> <li>2. Partial parallel mode: i.e., AACC mode, PV1 and PV2 are from the same source, PV3 and PV4 are from the same source.</li> <li>3. Independent mode: i.e., ABCD mode (different-source), PV1, PV2, PV3, PV4 are connected independently, each of the 4 PV channels connects to a separate solar panel.</li> </ol> <p>This fault is reported if the actual PV</p>	<p>Check if the PV access mode is set correctly (ABCD, AACC, AAAA). Reset the PV access mode correctly.</p> <ol style="list-style-type: none"> <li>1. Confirm that each actual PV channel is correctly connected.</li> <li>2. If the PV is correctly connected, check the currently set "PV Access Mode" via the APP or screen to see if it corresponds to the actual access mode.</li> <li>3. If the currently set "PV Access Mode" does not match the actual access mode, use the APP or screen to set the "PV Access Mode" to the mode consistent with the actual situation. After setting, disconnect the PV and AC power supply and restart.</li> <li>4. After setting, if the current "PV Access Mode" matches the actual access mode but this fault still occurs, please contact the dealer or after-sales service center.</li> </ol>

Fault Code	Fault Name	Possible Cause	Troubleshooting Suggestions
		access mode does not match the PV access mode set in the device.	

#### 9.5.2.2.4 Troubleshooting (Fault Codes F122-F163)

Fault Code	Fault Name	Fault Cause	Troubleshooting Suggestion
F123	Multi-PV Phase Error	PV Input Mode Setting Incorrect	<p>Check if the PV Access Mode is set correctly (ABCD, AACC, AAAA), and reset the PV Access Mode correctly.</p> <ol style="list-style-type: none"> <li>1. Confirm that all actual connected PV strings are correctly wired;</li> <li>2. If the PV strings are correctly connected, check via the APP or screen whether the currently set "PV Access Mode" corresponds to the actual connection mode;</li> <li>3. If the currently set "PV Access Mode" does not match the actual connection mode, use the APP or screen to set the "PV Access Mode" to the mode consistent with the actual situation. After setting, disconnect and restart the PV and AC power supply;</li> <li>4. After setting, if the current "PV Access Mode" matches the actual connection mode but the fault persists, please contact the dealer or after-sales service center.</li> </ol>
F124	Battery 1 Reverse Polarity fault	Battery 1 positive and negative poles reversed	Check if the polarities of the battery and the machine's terminals are consistent.
F125	Battery 2 Reverse Polarity fault	Battery 2 positive and negative poles reversed	Check if the polarities of the battery and the machine's terminals are consistent.
F126	Battery Abnormal Connection	Battery Abnormal Connection	Check if the battery is working normally.

<b>Fault Code</b>	<b>Fault Name</b>	<b>Fault Cause</b>	<b>Troubleshooting Suggestion</b>
F127	BAT Overtemperature	Battery temperature is too high, possible reasons: 1. Poor ventilation at the inverter installation location. 2. Ambient temperature is too high. 3. Internal fan operation is abnormal.	Disconnect the AC output side switch and DC input side switch, wait for 5 minutes, then close the AC output side switch and DC input side switch. If the fault persists, please contact the dealer or after-sales service center.
F128	Ref Voltage Abnormal	Reference circuit fault	Disconnect the AC output side switch and DC input side switch, wait for 5 minutes, then close the AC output side switch and DC input side switch. If the fault persists, please contact the dealer or after-sales service center.
F129	Cabinet Under Temperature	Cabinet temperature is too low, possible reason: Ambient temperature is too low.	Disconnect the AC output side switch and DC input side switch, wait for 5 minutes, then close the AC output side switch and DC input side switch. If the fault persists, please contact the dealer or after-sales service center.
F130	AC Side SPD fault	AC side surge protective device failure	Replace the AC side surge protective device.
F131	DC Side SPD fault	DC side surge protective device failure	Replace the DC side surge protective device.

Fault Code	Fault Name	Fault Cause	Troubleshooting Suggestion
F132	Internal Fan Abnormal	Internal fan abnormal, possible reasons: 1. Fan power supply abnormal; 2. Mechanical fault (stall); 3. Fan aging or damage.	Disconnect the AC output side switch and DC input side switch, wait for 5 minutes, then close the AC output side switch and DC input side switch. If the fault persists, please contact the dealer or after-sales service center.
F133	External Fan Abnormal	External fan abnormal, possible reasons: 1. Fan power supply abnormal; 2. Mechanical fault (stall); 3. Fan aging or damage.	
F134	PID Diagnosis Abnormal	PID hardware fault or PV voltage too high causing PID suspension	The PID suspension warning caused by high PV voltage requires no action. The PID hardware fault can be cleared by turning the PID switch off and then on. Replace the PID device.

Fault Code	Fault Name	Fault Cause	Troubleshooting Suggestion
F135	Trip-Switch Trip Warning	Possible reasons: Overcurrent or PV reverse polarity caused the trip-switch to open;	Contact the dealer or after-sales service center; The reason for tripping is a PV short circuit or reverse polarity. Check if there is a historical PV short circuit warning or historical PV reverse polarity warning. If present, maintenance personnel need to check the corresponding PV condition. After checking and confirming no fault, you can manually close the trip-switch and clear this warning via the APP interface's clear historical fault operation.
F136	Historical PV IGBT Short Circuit Warning	Possible reasons: Overcurrent caused the trip-switch to open;	Contact the dealer or after-sales service center; Maintenance personnel need to check the Boost hardware and external string corresponding to the historical PV short circuit warning subcode for faults. After checking and confirming no fault, this warning can be cleared via the APP interface's clear historical fault operation.

Fault Code	Fault Name	Fault Cause	Troubleshooting Suggestion
F137 , F138	Historical PV Reverse Polarity Warning (String 1-n) (n: determined by the actual number of inverter strings)	Possible reasons: PV reverse polarity caused the trip-switch to open;	Contact the dealer or after-sales service center; Maintenance personnel need to check the corresponding string for reverse polarity according to the historical PV reverse polarity warning subcode, and check if there is a voltage difference in the PV panel configuration. After checking and confirming no fault, this warning can be cleared via the APP interface's clear historical fault operation.
F139	Flash Read/Write Error Warning	Possible reasons: 1. Flash content has changed; 2. Flash lifespan exhausted;	1. Upgrade to the latest firmware; 2. Contact the dealer or after-sales service center.
F140	Meter Comm Loss	This warning may only occur after anti-backfeed function is enabled. Possible reasons: 1. Meter not connected; 2. Incorrect wiring of the communication cable between the meter and the inverter.	Check the meter wiring, connect the meter correctly. If the fault persists after checking, please contact the dealer or after-sales service center.
F141	PV Panel Type Identification Failure	PV panel identification hardware abnormal	Contact the dealer or after-sales service center.

<b>Fault Code</b>	<b>Fault Name</b>	<b>Fault Cause</b>	<b>Troubleshooting Suggestion</b>
F142	PV String Mismatch	PV string mismatch, two strings under the same MPPT have different open-circuit voltage configurations	Check the open-circuit voltages of the two strings, configure strings with the same open-circuit voltage under the same MPPT. Prolonged string mismatch poses a safety hazard.
F143	CT Not Connected	CT not connected	Check the CT wiring.
F144	CT Reverse Connection	CT reverse connection	Check the CT wiring.
F145	PE Loss	Protective earth not connected	Check the protective earth wire.
F146	String Terminal Temperature High (String 1~8)	Register 37176 PV terminal temperature alarm subcode 1 is set	-
F147	String Terminal Temperature High (String 9~16)	Register 37177 PV terminal temperature alarm subcode 2 is set	-
F148	String Terminal Temperature High (String 17~20)	Register 37178 PV terminal temperature alarm subcode 3 is set	-

<b>Fault Code</b>	<b>Fault Name</b>	<b>Fault Cause</b>	<b>Troubleshooting Suggestion</b>
F149	Historical PV Reverse Polarity Warning (String 33~48)	Possible reasons: PV reverse polarity caused the trip-switch to open;	Contact the dealer or after-sales service center; Maintenance personnel need to check the corresponding string for reverse polarity according to the historical PV reverse polarity warning subcode, and check if there is a voltage difference in the PV panel configuration. After checking and confirming no fault, this warning can be cleared via the APP interface's clear historical fault operation.
F150	Battery 1 Voltage Low	Battery voltage below set value	-
F151	Battery 2 Voltage Low	Battery voltage below set value	-
F152	Low Voltage of Battery Power	Battery in non-charging mode, voltage below shutdown voltage	-
F153	Battery 1 Voltage High	-	-
F154	Battery 2 Voltage High	-	-

<b>Fault Code</b>	<b>Fault Name</b>	<b>Fault Cause</b>	<b>Troubleshooting Suggestion</b>
F155	Online Low Insulation Resistance	1. Photovoltaic string shorted to protective earth. 2. Photovoltaic string installed in a long-term humid environment with poor line-to-earth insulation.	1. Check the impedance of the photovoltaic string to protective earth. If a short circuit is found, rectify the short point. 2. Check if the inverter's protective earth wire is correctly connected. 3. If it is confirmed that the impedance is indeed below the default value in rainy/cloudy conditions, please reset the "Insulation Resistance Protection Point".
F156	Micro-grid Overload Warning	backup port input current too high	Occasional occurrence requires no action; If this warning appears frequently, please contact the dealer or after-sales service center.
F157	Manual Reset	-	-
F158	Generator Phase Sequence Abnormal	-	-
F159	Multiplexed Port Configuration Abnormal	Multiplexed (Generator) port configured as micro-grid or large load, but a generator is actually connected	Use the APP to change the Multiplexed (Generator) port configuration.
F160	EMS Forced Off-grid	EMS issued forced off-grid command, but off-grid function is not enabled	Enable the off-grid function.

<b>Fault Code</b>	<b>Fault Name</b>	<b>Fault Cause</b>	<b>Troubleshooting Suggestion</b>
F161	Passive Anti-islanding Protection	-	-
F162	Grid Type Fault	Actual grid type (two-phase or split-phase) does not match the set safety standard	Switch to the corresponding safety standard according to the actual grid type.
F163	Grid Phase Instability	Grid abnormal: Grid voltage phase change rate does not comply with local grid standard.	<p>1. If it occurs occasionally, it may be a temporary grid anomaly. The inverter will resume normal operation after detecting normal grid conditions, requiring no manual intervention.</p> <p>2. If it occurs frequently, please check if the grid frequency is within the allowable range. If not, please contact the local power operator.</p>

#### 9.5.2.2.5 Fault Phenomenon Handling

Fault Name	Fault Cause	Fault Handling Recommendation
Generator Failure	<ol style="list-style-type: none"> <li>1. This fault will be displayed continuously when no generator is connected.</li> <li>2. This fault will be triggered if generator safety regulations are not met during generator operation.</li> </ol>	<ol style="list-style-type: none"> <li>1. If the generator is not connected, ignore this fault.</li> <li>2. It is normal for this fault to appear when the generator fails. Wait for a period after the generator recovers, and the fault will clear automatically.</li> <li>3. This fault does not affect the normal operation of the off-grid mode.</li> <li>4. When both the generator and grid are connected and meet safety requirements, the grid has priority for grid-connection, and the system will operate in grid-connected mode.</li> </ol>
BMS Status Bit Error	BMS module failure	Disconnect the AC output side switch and DC input side switch, wait for 5 minutes, then close the AC output side switch and DC input side switch. If the fault persists, please contact the dealer or after-sales service center.
Ambient Overtemperature	<ol style="list-style-type: none"> <li>1. Poor machine ventilation</li> <li>2. Hot air flow back to the ambient temperature sampling point</li> </ol>	Disconnect the AC output side switch and DC input side switch, wait for 5 minutes, then close the AC output side switch and DC input side switch. If the fault persists, please contact the dealer or after-sales service center.

Fault Name	Fault Cause	Fault Handling Recommendation
PV Terminal Overtemperature	PV terminal overtemperature, possible causes: 1. Poor ventilation at the inverter installation location. 2. Ambient temperature is too high. 3. Internal fan operation is abnormal.	1. Check if the ventilation at the inverter installation location is adequate and if the ambient temperature exceeds the maximum allowable range. 2. If ventilation is poor or the ambient temperature is too high, please improve the ventilation and heat dissipation conditions. 3. If both ventilation and ambient temperature are normal, please contact the dealer or after-sales service center.
BAT Terminal Overtemperature	BAT terminal overtemperature, possible causes: 1. Poor ventilation at the inverter installation location. 2. Ambient temperature is too high.	1. Check if the ventilation at the inverter installation location is adequate and if the ambient temperature exceeds the maximum allowable range.
AC Terminal Overtemperature Warning	AC terminal overtemperature, possible causes: 1. Poor ventilation at the inverter installation location. 2. Ambient temperature is too high. 3. Internal fan operation is abnormal.	2. If ventilation is poor or the ambient temperature is too high, please improve the ventilation and heat dissipation conditions. 3. If both ventilation and ambient temperature are normal, please contact the dealer or after-sales service center.

<b>Fault Name</b>	<b>Fault Cause</b>	<b>Fault Handling Recommendation</b>
BAT Terminal Overtemperature Warning	BAT terminal overtemperature, possible causes: 1. Poor ventilation at the inverter installation location. 2. Ambient temperature is too high.	1. Check if the ventilation at the inverter installation location is adequate and if the ambient temperature exceeds the maximum allowable range. 2. If ventilation is poor or the ambient temperature is too high, please improve the ventilation and heat dissipation conditions. 3. If both ventilation and ambient temperature are normal, please contact the dealer or after-sales service center.
Three-phase on-grid fault	Three-phase external wiring error	Re-wire.
External STS Failure	Abnormal cable connection between inverter and STS	Check if the wiring sequence of the harness between the inverter and the STS corresponds one-to-one in order.

<b>Fault Name</b>	<b>Fault Cause</b>	<b>Troubleshooting Recommendation</b>
Parallel Comm Timeout Shutdown	In parallel mode, if a slave unit has not communicated with the master for more than 400 seconds	Check if the parallel communication harness is securely connected. Check for duplicate slave addresses.
Three-phase off-grid phase loss fault	Phase loss in a three-phase system	1. Check if all inverters are powered on; 2. Check if inverters are connected to each phase in the three-phase system;

Fault Name	Fault Cause	Troubleshooting Recommendation
EPO	External hardware EPO button triggered or remote EPO command triggered	<ol style="list-style-type: none"> <li>1. If triggered remotely on purpose, it can be ignored;</li> <li>2. If not triggered on purpose, please contact the dealer or after-sales service center.</li> </ol>
High Flammable Gas Concentration	Automatically triggered when the gas detection device detects a concentration of 20% LEL or higher	<ol style="list-style-type: none"> <li>1. After the fault occurs, the unit will automatically open the air damper to exhaust and reduce the concentration. The fault will clear automatically after the concentration remains below 5% LEL for 15 minutes.</li> <li>2. If a cluster-level fire protection fault is triggered after this fault occurs, the air damper will automatically close. Confirm the damper status within 30s to ensure the cluster-level fire protection operates in a sealed space.</li> <li>3. Please contact the dealer or after-sales service center.</li> </ol>
Flammable Gas Device Air Damper Open Signal Mismatch	Mismatch between the control signal to open the air damper and the feedback signal	<ol style="list-style-type: none"> <li>1. Check the harness signal connection for issues.</li> <li>2. Please contact the dealer or after-sales service center.</li> </ol>
One-Key Shutdown	Check via the App if the one-key shutdown function is enabled	Disable the one-key shutdown.
Offline Shutdown	-	-

Fault Name	Fault Cause	Troubleshooting Recommendation
Remote Shutdown	-	-
On-Grid SPD Fault	-	<ol style="list-style-type: none"> <li>1. Try restarting the unit and observe if the fault clears;</li> <li>2. If the fault persists after restarting, please contact the dealer or after-sales service center.</li> </ol>
Off-Grid SPD Fault	-	<ol style="list-style-type: none"> <li>1. Try restarting the unit and observe if the fault clears;</li> <li>2. If the fault persists after restarting, please contact the dealer or after-sales service center.</li> </ol>
Child Node Communication Failure	Internal Comm Abnormal	<ol style="list-style-type: none"> <li>1. Try restarting the unit and observe if the fault clears;</li> <li>2. If the fault persists after restarting, please contact the dealer or after-sales service center.</li> </ol>
Dehumidifier Communication Fault	Abnormal communication link between the dehumidifier and the LC control box	<ol style="list-style-type: none"> <li>1. Check the link communication harness and observe if the fault clears;</li> <li>2. Try restarting the unit and observe if the fault clears;</li> <li>3. If the fault persists after restarting, please contact the dealer or after-sales service center.</li> </ol>

Fault Name	Fault Cause	Troubleshooting Recommendation
Flammable Gas Detection Device Communication Fault	<ol style="list-style-type: none"> <li>1. The flammable gas device left the factory without the 485 address properly configured to 2.</li> <li>2. Abnormal communication link between the gas device and the LC control box</li> </ol>	<ol style="list-style-type: none"> <li>1. Check the link communication harness and observe if the fault clears;</li> <li>2. Try restarting the unit and observe if the fault clears;</li> <li>3. Use the method provided by the gas device manufacturer to check if the device address is 2. If not, modify it;</li> <li>4. If the fault persists after restarting, please contact the dealer or after-sales service center.</li> </ol>
DG Communication Failure	Abnormal communication link between the control board and the diesel generator	<ol style="list-style-type: none"> <li>1. Check the link communication harness and observe if the fault clears;</li> <li>2. Try restarting the unit and observe if the fault clears;</li> <li>3. If the fault persists after restarting, please contact the dealer or after-sales service center.</li> </ol>
Battery Over Voltage	<ol style="list-style-type: none"> <li>1. Single cell voltage too high</li> <li>2. Voltage sensing line abnormal</li> </ol>	Record the fault phenomenon, restart the battery, wait a few minutes, and confirm if the fault disappears. If the problem persists after restarting, please contact the after-sales service center.
Battery Undervoltage	<ol style="list-style-type: none"> <li>1. Total battery voltage too high</li> <li>2. Voltage sensing line abnormal</li> </ol>	
	<ol style="list-style-type: none"> <li>1. Single cell voltage too low</li> <li>2. Voltage sensing line abnormal</li> </ol>	

Fault Name	Fault Cause	Troubleshooting Recommendation
	1. Total battery voltage too low 2. Voltage sensing line abnormal	
Battery Overcurrent	1. Charging current too high, battery current limiting abnormal: sudden change in temperature and voltage values 2. Inverter response abnormal	
	Battery discharge current too high	
Battery Overtemperature	1. Ambient Overtemperature 2. Temperature sensor abnormal	
Battery Undertemperature	1. Ambient temperature too low 2. Temperature sensor abnormal	
Battery Terminal Overtemperature	Terminal temperature too high	

Fault Name	Fault Cause	Troubleshooting Recommendation
Battery Imbalance	<ol style="list-style-type: none"> <li>1. Excessive temperature difference: At different stages, the battery will limit power, i.e., limit charge/discharge current. Therefore, this issue is generally difficult to occur.</li> <li>2. Cell capacity degradation leads to excessive internal resistance, causing large temperature rise during overcurrent and thus large temperature difference.</li> <li>3. Poor welding of cell tabs, causing the cell to heat up too quickly during overcurrent.</li> <li>4. Temperature sampling issue;</li> <li>5. Loose power line connection</li> </ol>	

Fault Name	Fault Cause	Troubleshooting Recommendation
	1. Inconsistent cell aging levels 2. Slave board chip issues can also cause excessive cell voltage difference; 3. Slave board balancing issues can also cause excessive cell voltage difference 4. Harness issues	
Insulation Resistance	Insulation resistance damaged	Check if the ground wire is properly connected, restart the battery. If the problem persists after restarting, please contact the after-sales service center.
Pre-charging Failure	Pre-charging Failure	Indicates that during pre-charging, the voltage across the pre-charge MOS始终 exceeds the specified threshold. Power off and restart to observe if this fault persists. Check if wiring is correct and if the pre-charge MOS is damaged.
Sensing Line Fault	Battery sensing line poor contact or disconnected	Check wiring, restart the battery. If the problem persists after restarting, please contact the after-sales service center.
	Cell voltage sensing line poor contact or disconnected	Check wiring, restart the battery. If the problem persists after restarting, please contact the after-sales service center.
	Cell temperature sensing line poor contact or disconnected	

Fault Name	Fault Cause	Troubleshooting Recommendation
	Dual-channel current comparison error too large, or current sensing line loop abnormal	
	Dual-channel voltage comparison error too large or MCU vs AFE voltage comparison error too large, or voltage sensing line loop abnormal	
	Temperature sensing line loop abnormal, poor contact, or disconnected	
	Overvoltage level 5 or overtemperature level 5, tripped three-terminal fuse	
Relay or MOS Overtemperature	Relay or MOS overtemperature	This fault indicates the MOS管 temperature exceeds the specified threshold. Power off and let it sit for 2h for temperature to recover.
Shunt Overtemperature	Shunt overtemperature	This fault indicates the shunt temperature exceeds the specified threshold. Power off and let it sit for 2h for temperature to recover.

Fault Name	Fault Cause	Troubleshooting Recommendation
BMS1 Other Fault 1 (Residential Storage)	Relay or MOS Open Circuit	<ol style="list-style-type: none"> <li>1. Upgrade software, power off and let it sit for 5 minutes, restart and see if the fault persists;</li> <li>2. If it persists, replace the battery pack</li> </ol>
	Relay or MOS Short Circuit	<ol style="list-style-type: none"> <li>1. Upgrade software, power off and let it sit for 5 minutes, restart and see if the fault persists;</li> <li>2. If it persists, replace the battery pack</li> </ol>
	Communication abnormal between main cluster and slave cluster, or cell inconsistency between clusters	<ol style="list-style-type: none"> <li>1. Check the slave battery information and software version, and if the communication line connection to the master is normal</li> <li>2. Upgrade software</li> </ol>
	Battery system loop harness abnormal, causing interlock signal not to form a loop	Check if the terminal resistor is installed correctly
	BMS and PCS communication abnormal	<ol style="list-style-type: none"> <li>1. Confirm if the communication line interface definition between the inverter and the connected battery is correct;</li> <li>2. Please contact the after-sales service center to check backend data and observe if the inverter and battery software match correctly.</li> </ol>
	BMS master and slave control communication harness abnormal	<ol style="list-style-type: none"> <li>1. Check wiring, restart the battery;</li> <li>2. Upgrade the battery software. If the problem persists after restarting, please contact the after-sales service center.</li> </ol>

Fault Name	Fault Cause	Troubleshooting Recommendation
	Communication lost between main positive and main negative chips	
	Circuit breaker, shunt trip abnormal	<ol style="list-style-type: none"> <li>1. Power off and let it sit for 5 minutes, restart and see if the fault persists;</li> <li>2. Check if the communication pins on the bottom blind plugs of the PACK and PCU are loose or misaligned;</li> </ol>
	MCU self-test failure	Upgrade software, restart the battery. If the problem persists after restarting, please contact the after-sales service center.
	<ol style="list-style-type: none"> <li>1. Software version too low or BMS board damaged</li> <li>2. Too many inverters in parallel, causing excessive inrush current during battery pre-charge</li> </ol>	<ol style="list-style-type: none"> <li>1. Upgrade software, observe if the fault persists.</li> <li>2. For parallel systems, black-start the battery first before starting the inverters.</li> </ol>
	MCU internal fault	Upgrade software, restart the battery. This usually indicates MCU or external component damage. If the problem persists after restarting, please contact the after-sales service center.
	Total control current exceeds specified threshold	<ol style="list-style-type: none"> <li>1. Power off and let it sit for 5 minutes, restart and see if the fault persists;</li> <li>2. Check if the inverter power setting is too high, causing it to exceed the bus load;</li> </ol>

Fault Name	Fault Cause	Troubleshooting Recommendation
	Inconsistent cells in parallel battery clusters	Confirm if the cells in the parallel battery clusters are consistent.
	Reverse polarity connection in parallel battery clusters	Check if the positive and negative terminals of the parallel battery clusters are reversed.
	Severe overtemperature/overvoltage etc. triggering fire protection system	Contact the after-sales service center.
Air Conditioner Failure	Air conditioner abnormal failure	Try restarting the system. If the fault is not resolved, please contact the after-sales service center.
	Cabinet door not closed	Check if the cabinet door is properly closed
	Supply voltage too high	Confirm if the supply voltage meets the air conditioner input voltage requirements. Re-power on after confirmation.
	Insufficient supply voltage	
	No voltage input	
	Unstable supply voltage	Try restarting the system. If the fault is not resolved, please contact the after-sales service center.
	Compressor voltage unstable	
	Sensor poor contact or damaged	
Air conditioner fan abnormal		

Fault Name	Fault Cause	Troubleshooting Recommendation
BMS1 Other Fault 2 (Residential Storage)	DCDC内部存在电压或者电流异常	Refer to specific DC fault content.
	DCDC过载或者散热器温度过高等	
	Cell sensing abnormal or inconsistent aging levels	Please contact the after-sales service center.
	Fan operation not executed normally	Please contact the after-sales service center.
	Output terminal screws loose or poor contact	1. Power off the battery, check wiring and output terminal screw condition 2. After confirmation, restart the battery, observe if the fault persists. If it does, please contact the after-sales service center.
	Battery used for too long or cells severely damaged	Please contact the after-sales service center to replace the pack.
	1. Software version too low or BMS board damaged 2. Too many inverters in parallel, causing excessive inrush current during battery pre-charge	1. Upgrade software, observe if the fault persists. 2. For parallel systems, black-start the battery first before starting the inverters.
	Heating film damaged	Please contact the after-sales service center.

Fault Name	Fault Cause	Troubleshooting Recommendation
	Heating film three-terminal fuse blown, heating function unavailable	Please contact the after-sales service center.
	Software model, Cell Type, hardware model mismatch	Check if the software model, SN, Cell Type, and hardware model are consistent. If not, please contact the after-sales service center.
	Thermal management board communication line break	1. Power off and let it sit for 5 minutes, restart and see if the fault persists; 2. If the fault does not recover, contact after-sales to replace the pack.
	Pack fan fault signal triggered	
DCDC Fault	Output terminal voltage too high	Check the output terminal voltage. If the voltage is normal and the fault does not clear itself after restarting the battery, please contact the after-sales service center.
	DCDC module detects battery voltage exceeds maximum charging voltage	Stop charging, discharge to below 90% SOC or let it sit for 2h. If无效 and the fault persists after restarting, please contact the after-sales service center.
	Heat sink temperature too high	Let the battery sit for 1h for the heat sink temperature to drop. If无效 and the fault persists after restarting, please contact the after-sales service center.
	Battery discharge current too high	Check if the load exceeds the battery's discharge capability. Turn off the load or stop the PCS for 60s. If无效 and the fault persists after restarting, please contact the after-sales service center.

Fault Name	Fault Cause	Troubleshooting Recommendation
	Output terminal power harness positive/negative reversed with parallel clusters or PCS	Turn off the battery manual switch, check if the output terminal wiring is correct, restart the battery.
	Output power relay cannot close	Check if the output terminal wiring is correct and if there is a short circuit. If无效 and the fault persists after restarting, please contact the after-sales service center.
	Power device temperature too high	Let the battery sit for 1h for the internal power device temperature to drop. If无效 and the fault persists after restarting, please contact the after-sales service center.
	Relay welded/stuck	If the fault persists after restarting, please contact the after-sales service center.
Battery Rack Circulating Current Failure	1. Cell imbalance 2. First power-on without full charge calibration	Record the fault phenomenon, restart the battery, wait a few minutes, and confirm if the fault disappears. If the problem persists after restarting, please contact the after-sales service center.
BMS1 Other Fault 3 (Utility Storage)	Communication abnormal with linux module	1. Check if the communication line connection is normal 2. Upgrade software, restart the battery and observe if the fault persists. If it does, please contact the after-sales service center.
	Cell temperature rise too fast	Cell abnormal, contact after-sales to replace the pack.
	SOC below 10%	Charge the battery.
	SN writing does not comply with rules	Check if the SN digit count is normal. If abnormal, please contact the after-sales service center.

<b>Fault Name</b>	<b>Fault Cause</b>	<b>Troubleshooting Recommendation</b>
	1. Communication abnormal within battery cluster daisy chain 2. Inconsistent cell aging levels between battery clusters	1. Check the pack contact condition within a single battery cluster 2. Confirm the usage of each battery cluster, such as cumulative charge/discharge capacity, cycle count, etc. 3. Please contact the after-sales service center.
	High humidity inside pack	-
	Fuse blown	Contact after-sales to replace the pack.
	Battery low power	Charge the battery.
BMS1 Other Fault 4 (Utility Storage)	Circuit breaker abnormal	Contact after-sales to replace the pack.
	External device abnormal	Contact after-sales to replace the pack.
Contact Failure 1	-	-
Contact Failure 2	-	-
Overload Protection (Ksic)	Sustained overload (exceeding 690KVA) for 10s	Please contact the after-sales service center.
Overload Protection (Smart Port)	Sustained overload (exceeding 690KVA) for 10s	Please contact the after-sales service center.
Overcurrent Protection (Ksic)	-	-

Fault Name	Fault Cause	Troubleshooting Recommendation
Overcurrent Protection (Smart Port)	-	-
Master AC On Meter Comm Error	1. Meter may not be connected to the master 2. Meter communication line may be loose	1. Check if the meter is connected to the master 2. Check if the meter communication line is loose
Parallel Slave Meter Error	Meter connected to a slave unit	Set the unit with the meter connected as the master
Slave AC On Timeout with Master	1. Slave address setting error 2. Slave communication line loose	1. Check for duplicate slave addresses 2. Check if the parallel communication line is loose

### 9.5.2.3 Battery Fault (LX A5.0-10)

● When the battery ALM indicator light shows red, locate and troubleshoot the fault in conjunction with the SOC indicator light display status.

No.	SOC Indicator	Fault Name	Solution
1	○○○○●	Battery Overvoltage	Power off and let it sit for 2 hours. If the problem persists after restarting, please contact the after-sales service center.
2	○○○●○	Battery Undervoltage	Please contact the after-sales service center.
3	○○○●●	High Cell Temperature	Power off and let it sit for 2 hours. If the problem persists after restarting, please contact the after-sales service center.





No.	SOC Indicator	Fault Name	Solution
4	○○●○○	Charging Low Temperature	Power off and wait for the temperature to recover. If the problem persists after restarting, please contact the after-sales service center.
5	○○●○○	Discharging Low Temperature	Power off and wait for the temperature to recover. If the problem persists after restarting, please contact the after-sales service center.
6	○○●●○	Charging Overcurrent	Restart the battery. If the problem persists after restarting, please contact the after-sales service center.
7	○○●●●	Discharging Overcurrent	Restart the battery. If the problem persists after restarting, please contact the after-sales service center.
8	○●○○○	Insulation Resistance Too Low	Please contact the after-sales service center.
9	○●○○●	Excessive Temperature Difference	Power off and let it sit for 2 hours. If the problem persists after restarting, please contact the after-sales service center.
10	○●○●●	Excessive Cell Voltage Difference	Restart the battery and let it sit for 12 hours. If the problem persists, please contact the after-sales service center.
11	○●●○○	Cell Inconsistency	Please contact the after-sales service center.
12	○●●○○	Wiring Harness Abnormality	Restart the battery. If the problem persists after restarting, please contact the after-sales service center.
13	○●●●○	MOS Failure to Close	Restart the battery. If the problem persists after restarting, please contact the after-sales service center.
14	○●●●●	MOS Failure to Close	Restart the battery. If the problem persists after restarting, please contact the after-sales service center.
15	●○○○○	Parallel Clustering Fault	Please check if the battery models match. If they do not match, please contact the after-sales service center.





No.	SOC Indicator	Fault Name	Solution
16	●○○○●	Interlock Signal Fault	Check if the terminal resistor is installed correctly. If the problem persists after restarting, please contact the after-sales service center.
17	●○○●○	BMU Communication Fault	Restart the battery. If the problem persists after restarting, please contact the after-sales service center.
18	●○○●●	MCU Internal Communication Fault	Restart the battery. If the problem persists after restarting, please contact the after-sales service center.
19	●○●○○	Circuit Breaker Sticking Fault	Please contact the after-sales service center.
20	●○●○○	Precharge Failure Fault	Restart the battery. If the problem persists after restarting, please contact the after-sales service center.
21	●○●●○	MOS Overtemperature Fault	Power off and let it sit for 2 hours. If the problem persists after restarting, please contact the after-sales service center.
22	●○●●●	Combiner Box Overtemperature Failure	Power off and let it sit for 2 hours. If the problem persists after restarting, please contact the after-sales service center.
23	●●○○○	Reverse Connection Fault	Please contact the after-sales service center.
24	●●●●●	Microelectronics Fault	Please contact the after-sales service center.

#### 9.5.2.4 Battery Fault (LX A5.0-30)



##### Alarm Status

● When the battery ALM indicator shows red, combine with the SOC indicator status to locate and troubleshoot the fault.



No.	SOC Indicator	Fault Name	Resolution
1		Battery Over Voltage Battery Undervoltage	<ol style="list-style-type: none"> <li>1. Check via the APP whether the inverter's charging current limit is set to 0. If it is 0, confirm that the communication cable connection between the battery and the inverter is reliable and communication is normal.</li> <li>2. Power off and leave idle for 5 minutes. After restarting, confirm if the fault persists.</li> <li>3. If the fault is not resolved, please contact the after-sales service center.</li> </ol>
2		Battery Overcurrent	<ol style="list-style-type: none"> <li>1. Check via the APP if the battery model is correct. Confirm if the battery's real-time current exceeds the charging current limit or discharge current limit. If so, please contact the after-sales service center.</li> <li>2. If it is lower, power off the battery or upgrade the firmware. Restart and confirm if the fault continues to occur.</li> <li>3. If the fault is not resolved, please contact after-sales.</li> </ol>
3		Battery Overtemperature Battery Undertemperature Battery Terminal Overtemperature	Power off and leave idle for 60 minutes, wait for the temperature to recover. If the problem persists after restarting, please contact the after-sales service center.
4		Battery Imbalance	

No.	SOC Indicator	Fault Name	Resolution
		SOH Too Low Fault	Power off and leave idle for 30 minutes. If the problem persists after restarting, please contact the after-sales service center.
5		Pre-charge Failure Fault	<ol style="list-style-type: none"> <li>1. Confirm whether the battery output terminals and the inverter are connected in reverse.</li> <li>2. Power off and leave idle for 5 minutes. If the problem persists after restarting, please contact the after-sales service center.</li> </ol>
6		Harness Fault	Confirm if the battery switch is closed. If the battery switch is closed and the problem persists, please contact the after-sales service center.
7		Relay or MOS Overtemperature Shunt Overtemperature	Power off and leave idle for 30 minutes. If the problem persists after restarting, please contact the after-sales service center.
		BMS Other Faults: Output Port Overtemperature Fault	<ol style="list-style-type: none"> <li>1. Check if the battery power cables are tightened.</li> <li>2. Power off and leave idle for 5 minutes. If the problem persists after restarting, please contact the after-sales service center.</li> </ol>
8		Other Protection: MOS Cannot Close	Power off and leave idle for 5 minutes. If the problem persists after restarting, please contact the after-sales service center.
9		Other Protection: MOS Sticking	

No.	SOC Indicator	Fault Name	Resolution
10	●○○○	Other Protection: Parallel Cluster Fault	<ol style="list-style-type: none"> <li>1. Confirm the type and installation position of the terminal resistor used is correct.</li> <li>2. Confirm that the communication cable connections between batteries, and between the battery and inverter, are reliable and communication is normal.</li> <li>3. If the fault is not resolved, please contact the after-sales service center.</li> </ol>
11	○○○○	Other Protection: Communication Loss with Inverter	<ol style="list-style-type: none"> <li>1. Confirm that the communication cable connections between batteries, and between the battery and inverter, are reliable and communication is normal.</li> <li>2. If the fault is not resolved, please contact the after-sales service center.</li> </ol>
12	●○○●	Other Protection: BMU Communication Fault	<ol style="list-style-type: none"> <li>1. Confirm the type and installation position of the terminal resistor used is correct.</li> <li>2. Confirm that the communication cable connections between batteries, and between the battery and inverter, are reliable and communication is normal.</li> <li>3. Power off and leave idle for 5 minutes. If the problem persists after restarting, please contact the after-sales service center.</li> </ol>
13	●○●○	Other Protection: Circuit Breaker Sticking Fault	Power off and leave idle for 5 minutes. If the problem persists after restarting, please contact the after-sales service center.
14	●●○○	Other Protection: Software Failure	Restart the battery. If the problem persists after restarting, please contact the after-sales service center.

No.	SOC Indicator	Fault Name	Resolution
15		Other Protection: Hardware Overcurrent Fault	
16		Other Protection: Microelectronics Fault	
		Heating Film Three-Terminal Abnormality	<ol style="list-style-type: none"> <li>1. Upgrade the software.</li> <li>2. Power off and leave idle for 5 minutes. If the problem persists after restarting, please contact the after-sales service center.</li> </ol>

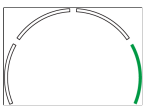

### 9.5.2.5 Battery Fault (GW16.1-BAT-LV-G10)

When the battery alarm indicator shows red , the outer ring marquee light shows red flashing , and the operation light is off, troubleshoot the fault by referring to the status indicated by the SOC indicator.

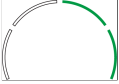
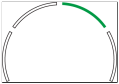
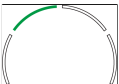
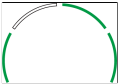
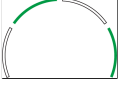
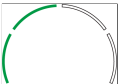
No.	SOC Indicator	Fault Name	Resolution
1		Battery Over Voltage	<ol style="list-style-type: none"> <li>1. Check via the App whether the inverter's charging current limit is 0. If it is 0, confirm the communication cable connection between the battery and inverter is reliable and communication is normal.</li> <li>2. Power off and let it sit for 5 minutes, then restart to confirm if the fault persists.</li> <li>3. If the fault is not resolved, please contact the after-sales service center.</li> </ol>
		Battery Undervoltage	

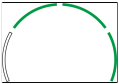
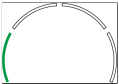
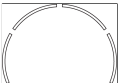
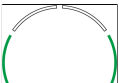
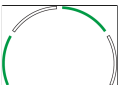
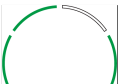
2		Battery Overcurrent	<p>1. Check via the App if the battery model is correct. Confirm if the battery's real-time current is greater than the charging current limit or discharge current limit value. Please contact the after-sales service center.</p> <p>2. If less, power off the battery or upgrade the software, then restart to confirm if the fault continues to occur.</p> <p>3. If the fault is not resolved, please contact after-sales.</p>
3		Battery Overtemperature	Power off and let it sit for 60 minutes, wait for the temperature to recover. If the problem persists after restarting, please contact the after-sales service center.
		Battery Undertemperature	
		Battery Terminal Overtemperature	
4		Battery Imbalance	Power off and let it sit for 30 minutes. If the problem persists after restarting, please contact the after-sales service center.
		SOH Too Low Fault	
5		Precharge Failure Fault	<p>1. Confirm if the battery output terminals and inverter are connected incorrectly.</p> <p>2. Power off and let it sit for 5 minutes. If the problem persists after restarting, please contact the after-sales service center.</p>
6		Acquisition Line Fault	Confirm if the battery circuit breaker is closed. If the battery circuit breaker is closed and the problem persists, please contact the after-sales service center.
7		Relay or MOS Overheating	Power off and let it sit for 30 minutes. If the problem persists after restarting, please contact the after-sales service center.

		Output Port Overheating	<ol style="list-style-type: none"> <li>1. Check if the battery power cables are tightened.</li> <li>2. Power off and let it sit for 5 minutes. If the problem persists after restarting, please contact the after-sales service center.</li> </ol>
8		MOS Cannot Close	Power off and let it sit for 5 minutes. If the problem persists after restarting, please contact the after-sales service center.
9		MOS Sticking	
10		Parallel Cluster Fault	<ol style="list-style-type: none"> <li>1. Confirm the type and installation position of the terminal resistor used are correct.</li> <li>2. Confirm the communication cable connections between batteries and between the battery and inverter are reliable and communication is normal.</li> <li>3. Use the battery SN code to confirm if the cells in the parallel cluster batteries are consistent.</li> <li>4. If the fault is not resolved, please contact the after-sales service center.</li> </ol>
11		Software/Hardware Version Mismatch	Restart the battery. If the problem persists after restarting, please contact the after-sales service center.
12		BMU Communication Fault	
13		Circuit Breaker Sticking Fault	Power off and let it sit for 5 minutes. If the problem persists after restarting, please contact the after-sales service center.
14		Software Failure	Restart the battery. If the problem persists after restarting, please contact the after-sales service center.

15		Hardware Overcurrent Fault	
16		Microelectronics Fault	
		Heating Film Three-Terminal Abnormality	<ol style="list-style-type: none"> <li>1. Upgrade the software.</li> <li>2. Power off and let it sit for 5 minutes. If the problem persists after restarting, please contact the after-sales service center.</li> </ol>

# 10 technical parameter

## 10.1 Battery Technical Data

### 10.1.1 LX A5.0-10

Technical Data	LX A5.0-10	2*LX A5.0-10	n*LX A5.0-10
Usable Energy (kWh) * <sup>1</sup>	5	10	n×5
Battery Module	LX A5.0-10: 51.2V 5.0kWh		
Number of Modules	1	2	n
Cell Type	LFP (LiFePO <sub>4</sub> )		
Nominal Voltage (V)	51.2		
Operating Voltage Range (V)	47.5~57.6		
Nominal Dis-/Charge Current (A) * <sup>2</sup>	60	120	n×60 * <sup>3</sup>
Nominal Power (kW) * <sup>2</sup>	3	6	n×3 * <sup>3</sup>
Operating Temperature Range (°C)	Charge: 0~+50; Discharge: -10~+50		
Relative Humidity	0~95%		
Max. Operating Altitude (m)	3000		
Communication	CAN		
Weight (kg)	40	80	n×40

Technical Data		LX A5.0-10	2*LX A5.0-10	n*LX A5.0-10
Dimensions (W×H×D mm)		LX A5.0-10 Module: 442×133×420 (Excluding hanger); 483×133×452 (Including hanger)		
Ingress Protection Rating		IP21		
Storage Temperature (°C)		0~+40 (< One Year); -20~0 (≤One Month); +40~+45(≤One Month)		
Mounting Method		Cabinet / Floor stacked / Wall-Mounted		
Round-trip Efficiency <sup>*4</sup>		95%		
Cycle Life <sup>*5</sup>		≥5000		
Standard and Certification	Safety	IEC62619, IEC63056, IEC62040-1, INmetro		
	EMC	EN IEC61000-6-1, EN IEC61000-6-2, EN IEC61000-6-3, EN IEC61000-6-4		
	Transportation	UN38.3, ADR		

\*1: Test conditions: 100% DOD, 0.2C charge & discharge at +25±2°C for battery system at beginning of life. System Usable Energy may vary with different Inverters.

\*2: Nominal Discharge/Charge Current and power derating will occur related to Temperature and SOC.

\*3: Based on Using a Battery Combiner Box to parallelize battery modules.

\*4: Based on a 2.5~3.65V voltage range @25±2°C of Cell under 0.2C/0.2C Cell test condition. Cell 0.6C/0.6C Round-trip Efficiency is approximately 94%~95%.

\*5: Based on a 2.87~3.59V voltage range @25±2°C of Cell under 0.6C/0.6C test condition and 70% EOL.

n: Max 15.

### 10.1.2 LX A5.0-30

Technical Parameters	LX A5.0-30
Nominal Capacity (kWh)	5.12
Usable energy (kWh) * 1	5
Cell Type	LFP (LiFePO4)
Operating Voltage Range (V)	43.2~58.24
Rated Capacity (Ah)	100
Nominal Charge Current (A) *2	60
Max. Continuous Charge Current (A) *2*3	90
Nominal Discharge Current (A) *2	100
Max. Continuous Discharge Current (A) *2*3	150
Max. Pulse Discharge Current (A)*2*3	<200A (30s)
Max. Continuous Discharge Power (W)	7200
Communication	CAN
Operating Temperature Range (°C)	Charge: $0 < T \leq 55$ Discharge: $-20 < T \leq 55$
Maximum Operating Altitude (m)	4000
Weight (Kg)	44
Dimensions (W x H x D mm)	442*133*520 (Excluding hanger) 483*133*559 (Including hanger)

<b>Technical Parameters</b>	<b>LX A5.0-30</b>
Ingress Protection Rating	IP20
Application Method	On-grid/On-grid + Backup/ off Grid
Scalability	Max. 30 in Parallel (150kWh) (Hand to hand /Combiner box /Busbar)
Mounting Method	19-inch standard rack, Floor-mounted, Wall-Mounted
Round-trip Efficiency* <sup>1</sup>	≥96%
Safety	IEC62619、IEC63056、N140
EMC	EN IEC61000-6-1、EN IEC61000-6-2、EN IEC61000-6-3、EN IEC61000-6-4
Transportation	UN38.3、ADR
Environment	ROHS

\*1 Test conditions: 100% DOD, 0.2C charge & discharge at 25°C± 2°C, at the beginning of life.

\*2 The system's working current and power values will be related to temperature and State of Charge (SOC).

\*3 Maximum charge / discharge current and power values may vary with different inverter models.

### 10.1.3 GW16.1-BAT-LV-G10

<b>Technical Data</b>	<b>GW16.1-BAT-LV-G10</b>
Battery Type	LFP (LiFePO4)
Rated Capacity (Ah)	314
Rated Energy (kWh)	16.1
Usable Energy (kWh)* <sup>1</sup>	≥14.9

<b>Technical Data</b>	<b>GW16.1-BAT-LV-G10</b>
Nominal Voltage(V)	51.2
Voltage Range(V)	45.92~57.76
Max. Continuous Charging Current (System) (A)	157
Max. Continuous Discharging Current (System) (A)	200
Max. Input.Power (kW) <sup>*2</sup>	8
Max. Output.Power (kW) <sup>*2</sup>	10
Peak Output Power (System)(kW) <sup>*2</sup>	16 (15s)
Charging Temperature Range(°C)	0~55
Discharging Temperature Range (°C)	-20~55
Relative Humidity	5-95%
Max. Operating Altitude (m)	4000
Communication	CAN
Weight (kg)	≤122
Useable Extinguishing Agent	CO2, H2O
Crucial Material	LiFePO <sub>4</sub> , C, Cu, LiPF <sub>6</sub> , Al, (C <sub>3</sub> H <sub>6</sub> )n
Ingress Protection	IP65
Protective Class	I
Dimensions (W×H×D mm)	≤470*895*245 (No base)
Optional Function Configuration	Regulating wheel (Optional); Aerosol fire extinguishing (Optional)
Storage Temperature (°C)	-20 ~45

Technical Data		GW16.1-BAT-LV-G10
Max. Storage time		-20-35°C≤12months
		35-45°C≤ 6 months
Scalability		30P
Mounting Method		Wall-Mounted、 Floor-Mounted
Cycle Life		≥6000 (25±2°C 0.5C 90%DOD 70% SOH )
Country of Manufacture		China
Standard and Certification	Safety	IEC62619, IEC60730, IEC63056, CE
	EMC	CE
	Transportation	UN38.3, MSDS

\*1: Test conditions: 100% DOD (cell voltage range 2.87~3.61V), 0.2P charge & discharge at 25±2°C for the battery system at the beginning of life. Usable energy is defined by its initial design value. Actual available energy may vary depending on charge/discharge rate, environmental conditions (e.g., temperature), and transport and storage factors.

\*2: Max. Input Power / Max. Output Power / Peak Output Power derating will occur related to Temperature and SOC.

\*3: This refers to the Cycle Life of the battery cell.

## 10.2 Smart Meter Technical Data

### 10.2.1 GMK110

technical parameter			GMK110
	Application		Single-phase
Input Parameters	voltage	Nominal Voltage (V)	220
		Voltage Range (V)	85~288

technical parameter		GMK110	
		Nominal Voltage Frequency (Hz)	50/60
	current	CT ratio	120A/40mA
		Number of CTs	1
Communication		RS485	
Communication Distance (m)		1000	
User Interface		2LED	
Accuracy	voltage/current		Class I
	Active Energy		Class I
	Reactive Energy		Class II
Power Consumption (W)		< 5	
Mechanical Parameters	Dimensions (W x H x D mm)		19*85*67
	Weight (g)		50
	Mounting Method		DIN Rail Mounting
Environmental Parameters	IP Rating		IP20
	Operating Temperature Range (°C)		-30 ~ 60
	Storage Temperature Range (°C)		-30 ~ 60
	Relative Humidity (no condensation)		0~95%
	Max. Operating Altitude(m)		3000

# 11 Appendix

## 11.1 FAQ

### 11.1.1 How to conduct auxiliary detection for smart meters/CT?

The meter detection function can check whether the meter CT is connected correctly and the current operational status of the meter and CT.

- Method One:

1. Go to the detection page via **[Home]** > **[Settings]** > **[Meter/CT Auxiliary Detection]**.
2. Click Start Detection, wait for the detection to complete, and then view the results.

- Method Two:

1. Click  > **[System Setup]** > **[Quick Setting]** > **[Meter/CT Assisted Test]** to enter the detection page.
2. Click Start Detection, wait for the detection to complete, and then view the results.

### 11.1.2 How to Upgrade the Device Version

Through firmware information, you can view or upgrade the inverter's DSP version, ARM version, BMS version, and communication module software version. Some communication modules do not support upgrading the software version via the App, please refer to the actual situation.

- **Prompt Upgrade:**

When the user opens the APP, an upgrade prompt pops up on the home page, and the user can choose whether to upgrade. If upgrade is selected, follow the on-screen prompts to complete the upgrade.

- **Regular Upgrade:**

Go to **[Home]** > **[Settings]** > **[Firmware Information]** to enter the firmware information view interface.

Click Check for Updates, if there is a new version, follow the on-screen prompts to complete the upgrade.

- **Forced Upgrade:**

The APP pushes upgrade information, and the user needs to upgrade as prompted, otherwise the APP cannot be used. Follow the on-screen prompts to complete the upgrade.

## 11.2 Explanation of Terms

- **Overvoltage Category Explanation**

- **Overvoltage Category I:** Equipment connected to circuits with measures to limit transient overvoltages to a relatively low level.
- **Overvoltage Category II:** Energy-consuming equipment supplied by fixed distribution installations. This category includes appliances, portable tools, and other household and similar loads. If special requirements for reliability and suitability of such equipment are needed, then Overvoltage Category III is adopted.
- **Overvoltage Category III:** Equipment in fixed distribution installations where reliability and suitability must meet special requirements. This includes switching devices in fixed distribution installations and industrial equipment permanently connected to fixed distribution installations.
- **Overvoltage Category IV:** Equipment used in the power supply of distribution installations, including measuring instruments and prefixed overcurrent protection devices, etc.

- **Damp Location Category Explanation**

Environmental Parameters	Levels		
	3K3	4K2	4K4H
Temperature Range	0~+40°C	-33~+40°C	-33~+40°C
Humidity Range	5% to 85%	15% to 100%	4% to 100%

- **Environmental Category Explanation:**

- **Outdoor Inverter:** Ambient air temperature range from -25 to +60°C, suitable for environments with Pollution Degree 3;
- **Indoor Type II Inverter:** Ambient air temperature range from -25 to +40°C,

suitable for environments with Pollution Degree 3;

- **Indoor Type I Inverter:** Ambient air temperature range from 0 to +40°C, suitable for environments with Pollution Degree 2;

- **Pollution Degree Category Explanation**

- **Pollution Degree 1:** No pollution or only dry non-conductive pollution;
- **Pollution Degree 2:** Generally only non-conductive pollution, but occasional temporary conductive pollution due to condensation must be considered;
- **Pollution Degree 3:** Conductive pollution exists, or non-conductive pollution becomes conductive due to condensation;
- **Pollution Degree 4:** Persistent conductive pollution, such as that caused by conductive dust or rain/snow.

## 11.3 Battery SN Code Meaning

\*\*\*\*\*2388\*\*\*\*\*  
                  └─┬─┘  
                  The 11th-14th digits

LXD10DSC0002

Digits 11-14 of the product SN code represent the production date code.

The production date in the image above is 2023-08-08

- Digits 11 and 12 represent the last two digits of the production year, e.g., 2023 is represented as 23;
- Digit 13 represents the production month, e.g., August is represented as 8;  
Details are as follows:

Month	Jan-Sep	Oct	Nov	Dec
Month Code	1~9	A	B	C

- Digit 14 represents the production day, e.g., the 8th day is represented as 8;  
Numbers are used preferentially, e.g., 1~9 represent the 1st~9th day, A represents the 10th day, and so on. The letters I and O are not used to avoid confusion. Details are as follows:

Production Date	Day 1	Day 2	Day 3	Day 4	Day 5	Day 6	Day 7	Day 8	Day 9
Code	1	2	3	4	5	6	7	8	9

Production Date	10th	11th	12th	13th	14th	15th	16th h	17th h	18th h	19th h	20th h
Code	A	B	C	D	E	F	G	H	J	K	L

Production Date	21st	22nd	23rd	24th	25th	26th h	27th h	28th h	29th h	30th h	31st
Code	M	N	P	Q	R	S	T	U	V	W	X

# 12 Contact Details

GoodWe Technologies Co., Ltd.  
No. 90 Zijin Rd., New District, Suzhou, China  
[en.goodwe.com](http://en.goodwe.com)  
service@goodwe.com